

May
1927



35
CENTS



RADIO BROADCAST

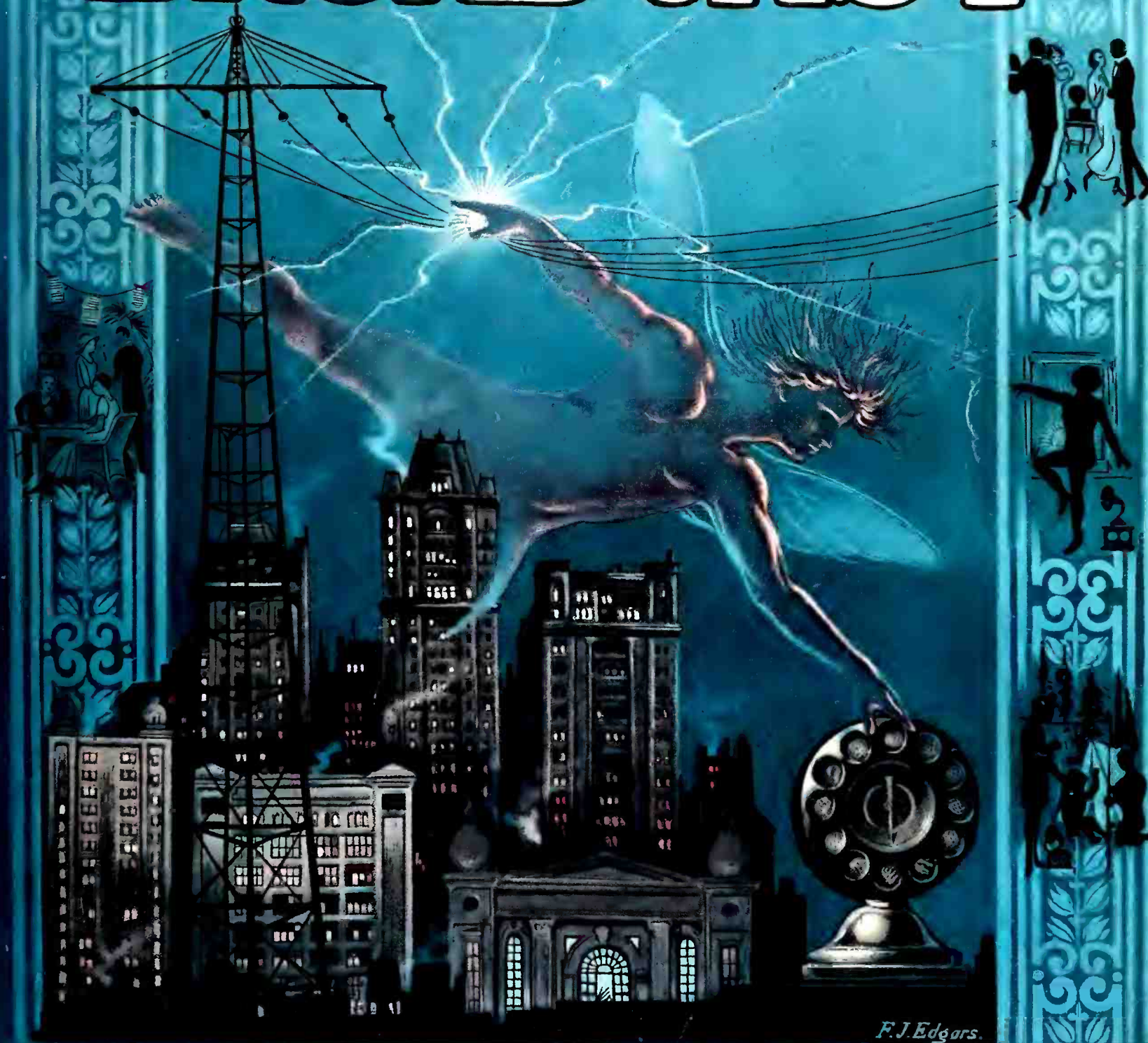

F.J. Edgars.

HOW TO ELECTRIFY YOUR PHONOGRAPH

[A Survey of the Preferences of Listeners—Facts About Modern Receiving Tubes—Problems of Series Filament Connection—The March of Radio—An Improved Socket Power Device—Facts About A-Potential Supplies—A New Short Wave Receiver]

Doubleday, Page & Company, Garden City, New York

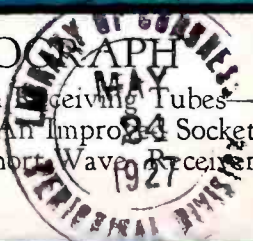

^{0.720}
The *Announcing*
New *Cunningham*

HI-MU Amplifier
type ~~CX~~ 340



Price
\$2.25

Five Volt
 $\frac{1}{4}$ amp. Filament
Mu of Thirty

The development of radio centers around the radio tube. In offering this new type we take another step forward in fulfilling the obligation of leadership.

With the advent of the CX-340, heights of efficiency heretofore unattainable in resistance and impedance coupled audio circuits are placed within easy reach of the radio world. This new Cunningham Radio Tube is especially designed for use in receiving sets employing resistance or impedance coupled audio frequency amplification.

Consult your dealer as to its proper installation or write us for the special CX-340 Bulletin.

Sixteen Types, all in the Orange and Blue Carton

E. J. Cunningham Inc.

NEW YORK

CHICAGO

SAN FRANCISCO

• • • Manufactured and sold under rights, patents and inventions owned and/or controlled by Radio Corporation of America • • •

Q · R · S

TRADE MARK
REGISTERED

Gaseous Rectifier Tubes

The Sensation of Radio
Development for your
Radio Battery Eliminator

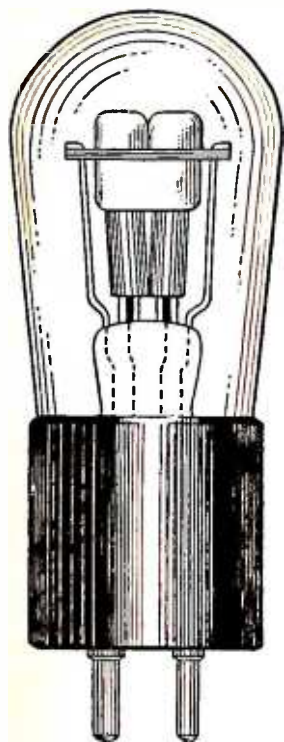

65 Milliampere and 85
Milliampere type for
B Battery Eliminators,
Price, \$5⁰⁰ each

When your B Eliminator needs a new tube ask for a Q · R · S Rectifier Tube with a guarantee of a full year's service or a refund for every month less than a year it fails to function.

In conjunction with a filter circuit for which we will furnish diagram and instructions free, the Q · R · S 400 Milliampere Tube will eliminate all A, B, and C Batteries and run your set from your house current supply.



400 Milliampere
type for A, B, and
C Battery Elim-
inators
\$ 7⁰⁰

For over a quarter of a century we have been manufacturing Quality merchandise—Quality always costs a little more but that's why

**Q · R · S Radio Tubes
Are Better**

For full details ask your dealer or if he is unable to serve you yet, address

The Q · R · S Music Company

Mfrs. of Q · R · S Player Rolls used in over a Million Homes

New York
135th St. & Walnut Ave.

Chicago
306 S. Wabash Ave.

San Francisco
306 7th St.



For Genuine Satisfaction

There is nothing so satisfying in radio reception as to know that every adjustment, affecting the sensitivity of your receiver, is correct.

A voltmeter will tell you much about your set that you are now guessing at. Take the filament voltage for example. You can only guess at the proper position for the filament rheostat, and it is one of the most important adjustments on your set.

The Jewell Pattern No. 135 is an ideal instrument for the set owner or builder. This two-inch panel mounting instrument is available as either voltmeter or milliammeter. It is of the very best construction operating on the D'Arsonval moving coil principle. Movement parts are all silvered and the scale is silver etched with black characters.

Ranges of 0-5, 0-8 or 0-10 volts and 0-10, 15, 25, 50 or 100 milliamperes are most popular. Other ranges are available.

Write for Radio Instrument Catalog No. 15-C

Jewell Electrical Instrument Co.

1650 Walnut Street, Chicago

"27 YEARS MAKING GOOD INSTRUMENTS"

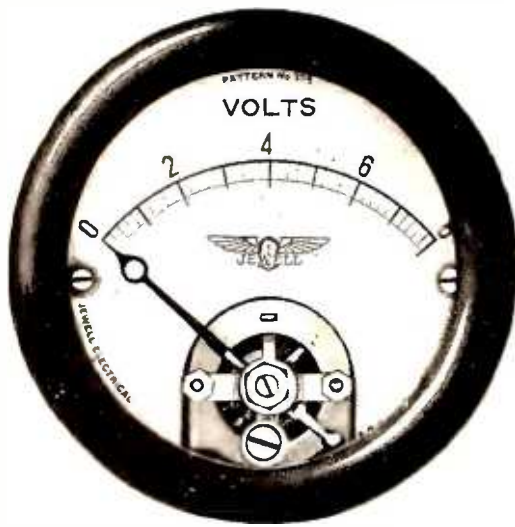

Pattern No. 135
Panel Mounting Instrument



GET DISTANCE

AMAZING INVENTION FOR ANY RADIO

Why confine your radio programs to a few local stations when the expensive concerts, dance music and lectures of hundreds of big cities are ready for you? Connect this DISTANCE GETTER to your radio, tune according to instructions and presto —note the distant programs roll in!

Satisfaction Guaranteed
Your money instantly refunded if you are not satisfied. The article on proper tuning furnished FREE with each Distance Getter, alone is worth the price. Galloway of Chicago writes: "Results beyond all expectations. Cuts through locals like a knife." Homes of Palos, Ill., says: "Send three more for my friends. I get Denver and California easily."

MAIL COUPON TODAY

HAZLETON LABORATORIES
4554 Malden St., Dept. R. B., Chicago, Ill.
Send me Distance Getter, postpaid. Enclosed find \$1.00 (M. O. stamps or check.)
Send C. O. D. plus small postage added.

Name.....
Address.....
City..... State.....

These Coils Improve Any Radio Receiver!

T. R. F. KIT



List \$12.00

This set of supersensitive Aero Tuned Radio Frequency Coils has never failed to improve the performance of any radio receiver. Tremendously increased power, extreme selectivity, and improved tone quality are sure to result from their use.

This kit of Aero Coils has a much lower high frequency resistance than other types of inductances. You should use them in any circuit, if you want the best possible results.

FREE Big 8-page, 4-colored layout system (actual size blue prints) and complete instructions for building the 5-tube Aero-Dyne Receiver free with each kit. Also insert showing how to wire for a power tube if desired. Extra copies, 75c each.

Get these Aero Coils from your dealer. If he is out of stock, order direct from the factory.

AERO PRODUCTS, INC., Dept. 109, 1772 Wilson Ave., Chicago, Ill.

SET BUILDERS Get this Book

Set builders, make money and greater profits with the *Camfield Super-Selective Nine*, the receiver of remarkable performance, that has caused a stir from coast to coast.

More Profits

The Citizens Radio Call Book article on *Camfield's Super-Selective Nine* has created a demand so great as to be unparalleled in radio history. Never before has a receiver received such favorable comment. It is truly a wonder circuit and one that every set builder will recognize instantly, once it is set up. Here is a field for more profits, greater satisfaction and really remarkable results. Send 25¢ today for booklet and have the facts before you.

CAMFIELD RADIO MFG. CO.
357-359 E. Ohio St. Dept. xxx Chicago, Ill.

Order your copy of *Radio Broadcast* from your news dealer or radio store. Make sure that he reserves a copy for you each month. If your favorite radio store does not stock the magazine write us giving name of radio dealer and address.

Copper Shielding

Gives better reception — closer selectivity and finer tone quality.

Sheet copper combines higher conductivity with easy working qualities.

COPPER & BRASS

RESEARCH ASSOCIATION

25 Broadway — New York

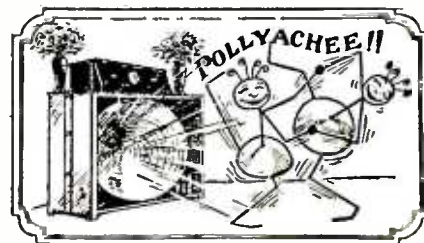

Only \$10 Make Your Own Three Foot Cone Speaker In Less Than An Hour Only \$10

Complete parts furnished in kit form. We guarantee this speaker the equal of any manufactured cone speaker at any price. With this THREE FOOT CONE SPEAKER you hear all the tones. It brings out the true depth and beauty of orchestral and instrumental music. Can be operated softly for living room music or full volume for dancing, and without trace of distortion.

Kit includes famous "ENSCO" cone unit, the only direct-drive, distortionless unit for large cones; Alhambra Fonotex for big cone, with brass apex, two Blue Prints showing cabinet or stand, wall, or roll type construction for cone speaker. All necessary instructions.

Buy this wonderful speaker under our absolute guarantee. Your money back if you are not convinced that it is the finest reproducing medium obtainable at any price. It works on any set, with ordinary Tubes or with Power Output.

SEND NO MONEY!

Write your name plainly as indicated below, then mail and complete kit will be forwarded to you. Just pay postman \$10.00 upon delivery.

Name.....
Address.....

ENGINEERS' SERVICE CO.
25 Church St. Desk X New York City

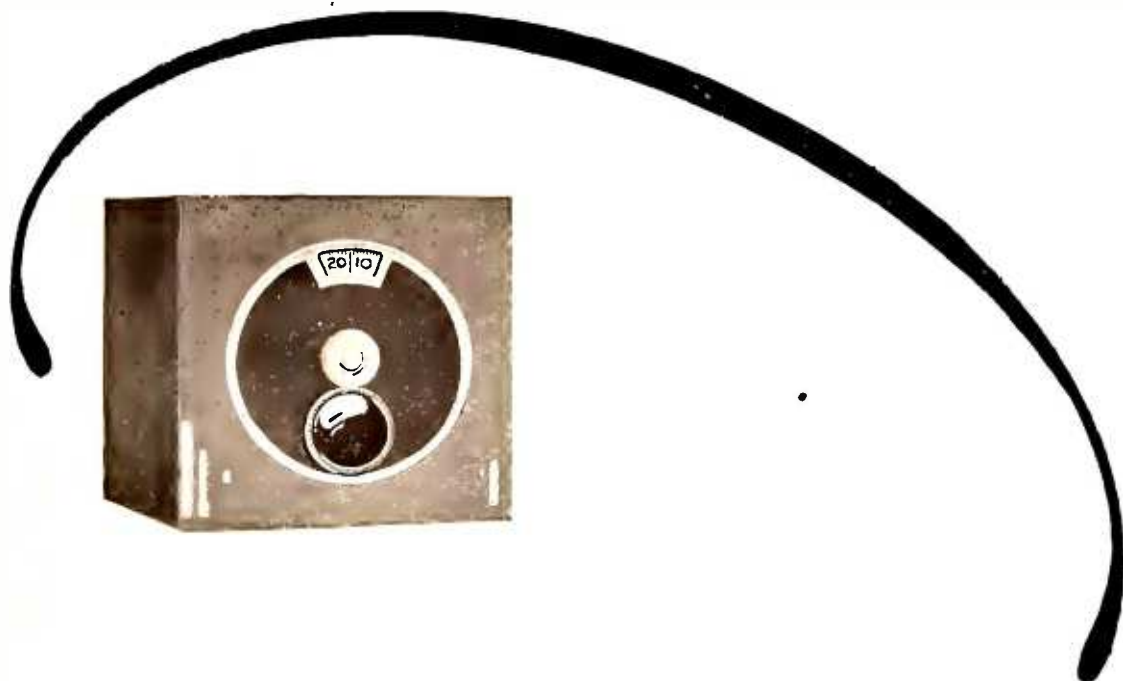

Trap the Offending Station!

The MADISON-MOORE WAVE TRAP

enables the user of a loop set in practically every locality to get within 10 to 20 kilocycles nearer the offending station. If, with your present receiver, you have trouble in eliminating powerful near-by stations, the Madison-Moore Wave Trap will materially assist the selectivity.

With this latest achievement in radio engineering, even small sets give satisfactory performance, making them more like loop sets.

The Madison-Moore Wave Trap is made of the finest materials, precision tested, in our laboratory. A model adapted for use with any set. It is encased in a No. 12 aluminum solid box; it tunes so sharply that a Vernier dial must be used. Simple to operate---comes complete with Vernier dial and instructions for connecting and operation. Priced within the reach of everyone.

The MADISON-MOORE WAVE TRAP is made by the
manufacturers of the famous
ONE●SPOT TRANSFORMER

[Try your dealer first. If he can't supply you, write us.]

MADISON-MOORE RADIO CORPORATION
2524 K Federal Boulevard
Denver, Colorado - U. S. A.

MADISON~MOORE

The Finest RADIO APPARATUS in the World!

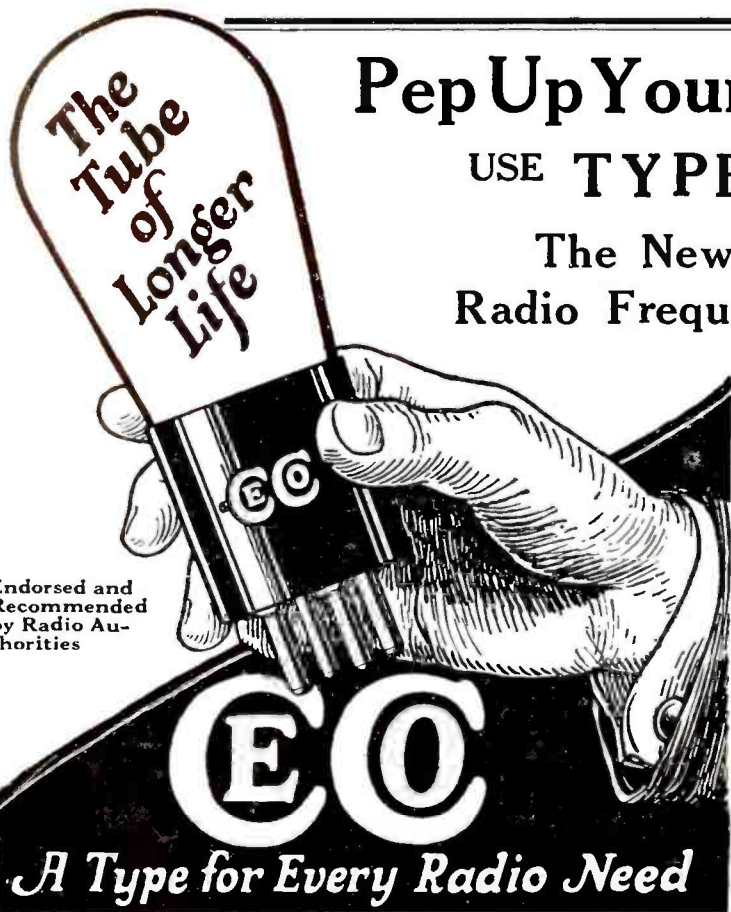

The Tube of Longer Life

CEC

A Type for Every Radio Need

Pep Up Your Receiver

USE TYPE "K"

The New **CEC**
Radio Frequency Tube

Tends to increase distant reception while improving the tone.

Price **\$3.00**

Write for complete data sheet

C. E. MFG. CO.
INC.
Providence, R.I., U.S.A.

Endorsed and Recommended by Radio Authorities



AMSCO

FLOATING SOCKETS

Stop microphonic noises, mechanical feed-back and audio vibration!

AmSCO Floating Sockets make it possible to operate your tubes at highest efficiency.

They take all the new type tubes—with the click that guarantees positive contact.

Ask your dealer or write for leaflet
AMSCO PRODUCTS, INC.
Broome and Lafayette Streets
New York City



FOR INFORMATION ON SPECIAL EQUIPMENT

Write to

NORDEN-HAUCK, INC.

Engineers

Builders of the Highest Class Radio Apparatus in the World.

Marine Building

PHILADELPHIA, PA.

Learn the Code at Home With the Omnigraph

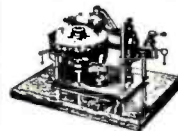

Morse and Wireless—taught at home in half usual time and at trifling cost. Omnigraph Automatic Transmitter will send, on Sounder or Buzzer, unlimited messages, any speed, just as expert operator would. Adopted by U. S. Govt. and used by leading Universities, Colleges, Technical and

Telegraph Schools throughout U. S. Send 6c for Catalog.

OMNIGRAPH MFG. CO., 13K, Hudson St., New York

Helpful Technical Information

A regular feature of RADIO BROADCAST is the series of Laboratory Information Sheets, which cover a wide range of information of immediate value to every radio worker, presented in a form making it easy to preserve them. To insure your having every issue, send your check for \$4.00 to

Subscription Department, Doubleday, Page & Co., Garden City, N. Y.



A NEW BOOKLET

36 pages of the latest radio diagrams, parts, circuits and blueprints.

General description and constructional data written in simple style by a Master of radio technique. Truly instructive.

4 wiring diagrams, 4 circuits, 4 blueprints, 47 illustrations, 3 complete pages of parts, 36 pages of radio knowledge.

Send 25 cents for your copy

BRUNO RADIO CORPORATION, Long Island City, N. Y.

Mayolian
"B" SUPPLY

Type 612—\$42.50

The "B" Without a Buzz



Also—Complete set of parts for home-builders at reasonable prices. Write us.

MAYOLIAN RADIO CORPORATION
1668 Webster Ave., New York, N. Y.

Pioneers in Battery Elimination



The Power of Niagara—
The Quiet of an Arctic Night



\$25

The **SNOCHORDE CONE**

HEAR this cone on both music and voice and you'll never be satisfied with any other. Equipped with super-powered unit with four heavy magnets, balanced and angularly spaced. Rich wine-colored silk front, unbreakable mahogany finish frame, protected back.

Ask your Dealer or Write Us.

BOUDETTE MFG. CO.
Chelsea, Mass.

centralab Station Selector



BIGGEST Dollar's Worth in Radio. Tunes out short wave interference, increasing selectivity of any set (not using loop) on stations close to local, except same wave length stations. Not a wave trap. No adjustments. At dealer's or send us dollar bill. **Money-Back Guarantee.** Satisfaction guaranteed.

Central Radio Laboratories
22 Keefe Ave. Milwaukee, Wis.
Parts manufacturers for 69 makers of leading standard sets.

Centralab

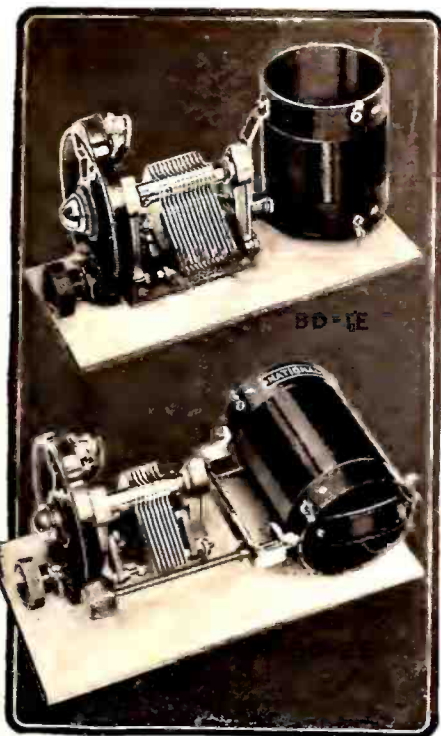

NATIONAL TUNING UNITS

New Type

Designed and Officially Approved
by Glenn H. Browning

These new NATIONAL TUNING-UNITS comprise the OFFICIAL BROWNING-DRAKE Coils and R. F. Transformers, mounted on the New NATIONAL EQUI-TUNE Variable Condensers with their light, rigid Girder-Frames.

Each TUNING-UNIT is

fitted with a NATIONAL ILLUMINATED VEL-VET-VERNIER DIAL—Type C, with variable ratio and smoothest action. Each tuning unit is packed mounted as shown so that it may be used without change for experimental work or easily installed on a panel.

NATIONAL TUNING UNITS
COVER THE BROADEST BAND

Price BD-1E, with Genuine BD Antenna Coil and .0005 Condenser \$10.75

Price BD-2E, with Genuine B-D Transformer and .00025 Condenser \$14.25

NATIONAL Tuning Units are standard for good Radio sets. So are NATIONAL Impedance Transformers for quality audio, NATIONAL Tone-Filters, for power tube output connection.



NATIONAL Co. makes heavy-duty B-Supply Units and 3-stage Power Amplifiers. Write National Company, Inc., W. A. READY, President, Cambridge, Mass., for Bulletin 116-B-3.

BROADCASTING FROM THE INSIDE

EVERY month in RADIO BROADCAST appears the department, "As the Broadcaster Sees It," written by Carl Dreher, one of the best known broadcast engineers in the country. Alive with humor, news, apt and searching comment, Mr. Dreher's writings have become one of the most popular features of radio writing anywhere. Are you reading it? Subscribe by the year and make sure of not missing a single issue. Mail your check for \$4.00 to Subscription Department, Doubleday, Page & Co., Garden City, N. Y.

LYNCH METALLIZED

WARRANTED FIXED RESISTORS

HEAVY-DUTY TYPE

The new Lynch wire-wound heavy duty resistors for eliminator and power work are now ready. These units are ideal for use in Raytheon and all other power circuits.

EQUALIZORS

For perfect filament control use the Lynch Equalizers. There is a type for every type of tube and for any combination of tubes. A Lynch Equalizer will take the place of your filament rheostats. Complete with mounting, \$1.00.

Lynch Suppressors and Low-loss mountings mean better radio.

At All Good Dealers

ARTHUR H. LYNCH, INC.



250 W. 57th St.
New York, N. Y.

AmerTran Power Transformer
Type PF52 \$18.00 Each

AMERTRAN RADIO PRODUCTS

AmerTran DeLuxe Audio Transformer. Two types for 1st and 2nd Stages \$10.00 Each

AmerChoke Type 854
\$6.00 Each

BRING YOUR SET UP-TO-DATE WITH AMERTRAN RADIO PRODUCTS

Today, the better class of broadcast stations are radiating fine programs with the highest quality possible. To take full advantage of this the audio amplifier in your set should be up-to-date. You can make this improvement by installing a pair of AmerTran DeLuxe audio transformers. In so doing be sure your last tube is a power tube capable of handling the higher plate voltages and current. It will then take care of the greater input signal and not overload or blast. The quality of reproduction will more than repay you for investing in AmerTrans. The tones from your cone speaker will be faithful and life-like. You will realize a new degree of reality from all good broadcasting.

Eliminating Batteries

AmerTran Power Transformer Type PF52, AmerChokes Type 854 and the AmerTran Resistor Type 400 will enable you to construct the best of high voltage plate supplies. And with slight changes in your set, you may eliminate entirely all batteries.

Write for further information that will enable you to make your present or contemplated set meet the high standards of modern broadcasting.

Free Booklet "Improving the Audio Amplifier" and other technical data will be sent on request.

AMERICAN TRANSFORMER COMPANY

178 Emmet Street

Newark, N. J.

"Transformer Builders for over 26 Years"

Sold only at authorized

AMERTRAN
DEALERS



Automatic Power Control

Here is the way to control the switching of your B eliminator and trickle charger or either automatically.

When you turn the switch on your set, the Automatic Power Control switches on the B eliminator and cuts out the trickle charger or does either. When you turn the set off, the Power Control is working automatically, surely and without fail turning off the B eliminator and the trickle charger on.

No. 444 Automatic Power Control, Series Type—for use with sets having tubes with a current draw equal to or greater than 6 U. V.-199 type of tubes. Each \$5.00.

At your dealer's. If he cannot supply you send his name with your order to

Yaxley Mfg. Co.

Dept. B, 9 So. Clinton St. Chicago, Ill.



Specialization Has Its Reward

Dongan, for years, has maintained complete experimental laboratories. Many of the advancements in design have found their origin in the Dongan plant. All this time, Dongan has specialized in one thing—the manufacture of transformers and chokes.

Today—manufacturers of receiving sets, power amplifiers and eliminators, look to Dongan as the logical source of supply on standard and special transformers.

DONGAN ELECTRIC MFG. CO. 2991-3001 Franklin St., Detroit, Michigan



The flux is everything in radio soldering says this Radio Engineer

"In our laboratory we made a thoro analysis of the two groups of fluxes (natural and chemical). We found the natural flux, rosin, the only safe one to use on radio work.

Pure rosin, as in Kester Radio Solder, will not fume, sputter, or creep over large areas, and being a hard, dense substance, rosin will not attract and collect dust (carbon particles), which makes an excellent path for leakages. These are the faults of fluxes containing chloride, be it either in paste, liquid or compound form. Any flux containing chloride will eventually cause heavy leakage. Hence they should be strictly avoided.

We find Kester Radio Solder the most convenient way to solder on radio work, for it has the proper amount of pure rosin right inside the solder itself. In fact, we used it exclusively on all of our work."

There's your guide, radio fans—the approval of an expert radio engineer. Surely there can be no doubt as to what you should use on YOUR SET.



A free Sample write for it now

KESTER Radio SOLDER

the safe solder for radio, requires only heat

CHICAGO SOLDER CO.

4222 Wrightwood Ave. Chicago, U. S. A.

Originators and the World's Largest Manufacturers of Self-fluxing Solder

FROST-RADIO FROST-RADIO FROST-RADIO FROST-RADIO

FROST-RADIO

IMPROVE THE OPERATION OF YOUR SET



By equipping your receiver with Frost-Radio Super Variable High Resistance Units, Rheostats, Potentiometers, Gem-Jacs, Plugs and other items from our line of high quality apparatus you will greatly increase its efficiency—secure better reception—and improve its operation. Every Frost-Radio Product is designed to give 100% efficiency—and delivers it.

YOUR DEALER CAN SUPPLY YOU

Ask your dealer for Frost-Radio. Have him show you the new Super Variable High Resistance Unit, in resistances of from 50,000 to 500,000 ohms, list \$1.25. Metal Frame Rheostats, 2 1/2 to 75 ohms, list 50c. (Bakelite Type, 75c) or other items that you will find mighty useful in your new receiver. Write us for complete descriptive literature.



MEMBER RMA HERBERT H. FROST, Inc. 160 N. La Salle St., Chicago New York Los Ang

FROST-RADIO FROST-RADIO FROST-RADIO FROST-RADIO

Fahnestock Clips RADIO'S GREATEST CONVENIENCE

Used by Manufacturers of Standard Sets and Parts—and by Manufacturers of High Grade Wet and Dry Batteries.



ALL GENUINE FAHNESTOCK CLIPS

bear our imprint on the thumb piece of the clip.

WORLD'S LARGEST MAKER OF CLIP TERMINALS

48 different sizes and styles to meet all requirements.

Send for Catalog and Samples

FAHNESTOCK ELECT. CO. L. I. City New York



R U ONE?

Co-operative membership in E I A RADIO is establishing an honest, industrious man in each locality in a successful radio industry of his own. Young married men preferred. Apply by letter, giving the name of your country, to

EQUITABLE INDUSTRIES ASS'N, RADIO DIV. 350-B Broadway, New York

The AIRGAP SOCKET

"It gets that last mile"



Results in easier tuning, more distance, volume and clarity—greater stability. Indorsed by leading authorities.

MODEL "N" A slight turn obtains correct tube oscillation on all tuned radio frequency circuits. Neutrodyne, Roberts two tube Browning-Drake McMurdo Silver's Knockout, etc., capacity range 1.8 to 20 micro-microfarads. Price \$1.00
MODEL "G" With grid clips obtains the proper grid capacity on Cockaday circuits, filter and intermediate frequency tuning in heterodyne and positive grid bias in all sets. Capacity range.
Model G-1—.0002 to .0001 MFD
Model G-5—.0001 to .0005 MFD
Model G-10—.0003 to .001 MFD
Price \$1.50

X-L PUSH POST. Push it down with your thumb, insert wire, remove pressure and wire is firmly held. Releases instantly. Price 15c

PUSH POST PANEL permanently marked in white on black rubber. In box including soldering lugs, raising bushings and screws for mounting. Price \$1.50

Free Wiring Diagrams showing use in most popular circuits. Write to-day.



X-L Radio Laboratories 2424 Lincoln Ave. CHICAGO, ILL.

ALUMINUM BOX SHIELDS

Made of "Alcoa Aluminum"

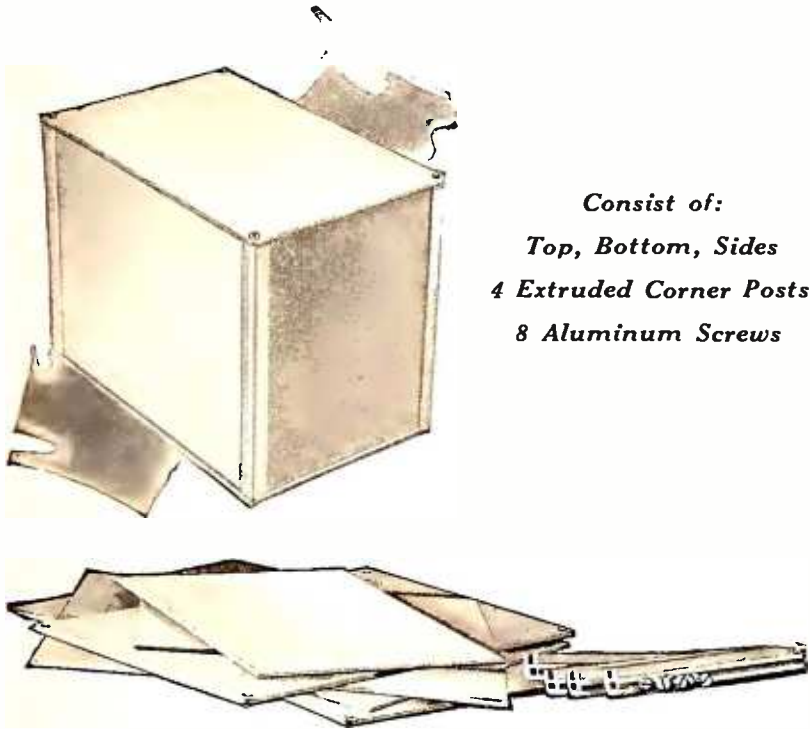

Consist of:
Top, Bottom, Sides
4 Extruded Corner Posts
8 Aluminum Screws

MEEETING the highest radio standards—shipped to you in the most convenient knocked-down form for easy assembly. These Box Shields are made of heavy aluminum (.080"—No. 12 B. & S.) and are supplied 5" x 9" x 6", which will cover most requirements. If the size does not meet your exact needs, change it—Aluminum is easy to work.

Manufacturers can obtain these shields made to their exact specifications or they can secure the necessary corner-post moulding and sheet to manufacture under their own supervision.

Those who use Aluminum have ample proof of its advantages. Insist on "Alcoa Aluminum," ask your dealer or write us.

"ALCOA ALUMINUM" is furnished to manufacturers in the following forms:

- Sheet: for shields, chassis, variable condensers, cabinets.
- Panels finished in walnut and mahogany.
- Die and Sand Castings.
- Screw Machine Products.
- Foil for fixed condensers.
- High Purity Rods for rectifiers.
- Stamping, rod, wire, rivets.

ALUMINUM IN EVERY COMMERCIAL FORM



ALUMINUM COMPANY of AMERICA

2320 OLIVER BUILDING, PITTSBURGH, PA.



Output of Battery Eliminators

THE ordinary type of low resistance voltmeter cannot be used to measure the output of battery eliminators because most eliminators cannot deliver sufficient current to operate the voltmeter and still maintain their voltage. For this service Weston now offers a special voltmeter with an exceptionally high self-contained resistance of 1,000 ohms per volt—Model 489 Battery Eliminator Voltmeter. This new instrument, because of its high resistance, requires a current of only one milliampere to produce full scale deflection. It is made in two double range combinations of 200/8 and 250/50 volts. The latter range can be supplied with an external multiplier to increase it to 500 volts. Ask your dealer or address—

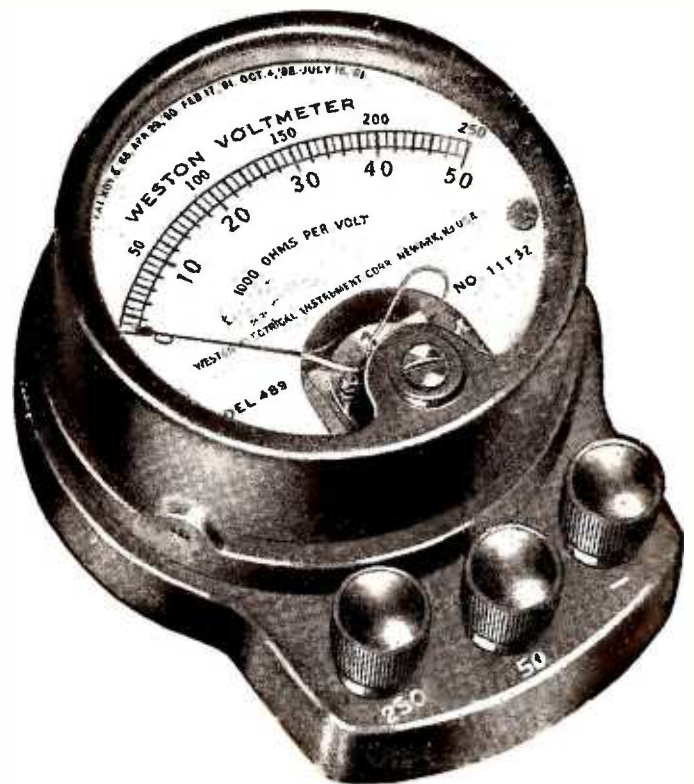

WESTON ELECTRICAL
INSTRUMENT CORPORATION

179 Weston Avenue, Newark, N. J.



RADIO BROADCAST

WILLIS K. WING, Editor

MAY, 1927

KEITH HENNEY
Director of the Laboratory

JOHN B. BRENNAN
Technical Editor

Vol. XI, No. 1

EDGAR H. FELIX, Contributing Editor

CONTENTS

Cover Design	From a Painting by Fred J. Edgars	
Frontispiece	The Towers of Station WOW, at Omaha, Nebraska	10
With MacMillan to the Arctic	Austin G. Cooley	11
The March of Radio	An Editorial Interpretation	15
What Does the Listener Want? Let Him Speak	"Christian" Mud Throwing	
Questionnaire: Which Stations Shall Broad-	A New Term for "A. C. Supply" Units	
cast?	There Are no Radio Engineers	
Objections to the Radio Law	A Survey of Radio Conditions	
The Question of Vested Rights	The Month in Radio	
The Electrical Phonograph	James Millen	20
A Balanced Short-Wave Receiver	Frank C. Jones	24
What About the A Battery?	Edgar H. Felix	26
The Listeners' Point of View	John Wallace	29
How Long Will Radio Broadcasting Prosper?	Microphone Miscellany	
Why a Good Program Was Good	Communications	
Thumb Nail Reviews	What the Listener Likes and How He Likes It	
Filament Lighting from the A. C. Mains	Roland F. Bers	33
As the Broadcaster Sees It	Carl Dreher	36
One Explanation of the Plethora of Broad-	The Radio Club of America	
casting Stations	Technical Operation of Broadcasting Stations	
Broadcasting and Social Upheavals	(Volume Indicators)	
Glad Tidings From the West	Something About Gain Control	
Some Facts About Coil Design	Ross Gunn	40
Perfecting the B Socket Power Device	Howard E. Rhodes	43
Methods of Measuring Tube Characteristics	Keith Henney	46
"Radio Broadcast's" Laboratory Information Sheets		52
No. 89 Short-Wave Coils	No. 93 Audio Amplifying Systems	
No. 90 Loop Antennas	No. 94 The Principle of Reflexing	
No. 91 A Simple Tube Tester	No. 95 Storage Batteries	
No. 92 Circuit Diagram of Tube Tester	No. 96 Analysis of Voice Frequencies	
Equipment for the Home Constructor		58
A Key to Recent Radio Articles	E. G. Shalkhauser	60
International Short-Wave Test		60
Manufacturers' Booklets Available		61

AMONG OTHER THINGS.

WITH this issue, RADIO BROADCAST starts its sixth year of publication. The five years just concluded have seen many changes in the radio industry and among radio experimenters and fans. American radio magazines of to-day are quite different from those of 1922; RADIO BROADCAST has changed considerably, both in physical appearance and in type of contents, since those days. We believe the changes are improvements, for certainly our files are filled with countless letters of approval. The aim of Doubleday, Page & Company has been to publish the highest class radio magazine possible. This we have attempted to do, first, in setting the standard of physical appearance of the magazine where it now is, and secondly, to spare no pains or expense in making our technical material as completely accurate and helpful as possible. Two large laboratories are maintained in Garden City where practical and theoretical experiments are constantly under way; and our advertising pages are carefully supervised.

MANY editorial features in RADIO BROADCAST have given the magazine a unique position in its field. The "March of Radio" provides an editorial comment and suggestion about all branches of radio. "The Listeners' Point of View" stands alone as a national review of broadcasting, particular and general. "As the Broadcaster Sees It" has turned out to be a unique department (prepared, incidentally, by one of the ablest broadcast engineers in the country) where engineer, program director, listener, and general reader alike, may meet. The review of current radio periodicals, the Laboratory Data Sheets, the listing of informative manufacturers' booklets, all furnish valuable information for our readers. Our constructional articles are chosen carefully for accuracy and greatest help and interest for the reader. We are at work on an editorial schedule now which holds much for everyone interested in radio in all its branches. Unfortunately there is insufficient space here to outline that schedule, but we prefer to let each issue of RADIO BROADCAST speak for itself in that connection.

PRINTERS' INK, in its tabulation of advertising lineage for March magazines, shows that RADIO BROADCAST led the field with a total of 20,621 lines, followed by *Radio News* with 18,930 lines, *Popular Radio* with 14,872, *Radio* with 12,770, and *Radio Age* with 4395.

IN THE JUNE RADIO BROADCAST, a fine story for the home experimenter is scheduled, describing the construction and use of a modulated oscillator. Other articles deal with short waves, the problems of series filament connection for 201-A type tubes, how to use new apparatus, technical problems for broadcast operators and others, and many other features of unusual interest.

WILLIS K. WING.

Doubleday, Page & Co.
MAGAZINES
COUNTRY LIFE
WORLD'S WORK
GARDEN & HOME BUILDER
RADIO BROADCAST
SHORT STORIES
EDUCATIONAL REVIEW
LE PETIT JOURNAL
ET I-CO
FRONTIER STORIES
WEST

Doubleday, Page & Co.
BOOK SHOPS
(Books of all Publishers)
NEW YORK { LORD & TAYLOR
PENNSYLVANIA TERMINAL (2 Shops)
GRAND CENTRAL TERMINAL
38 WALL ST. and 520 LEXINGTON AVE.
848 MADISON AVE. and 166 WEST 32ND ST.
ST. LOUIS: 223 N. 8TH ST. and 4914 MARYLAND AVE.
KANSAS CITY: 920 GRAND AVE. and 206 W. 47TH ST.
CLEVELAND: HIGBEE CO
SPRINGFIELD, MASS.: MEEKINS, PACKARD & WHEAT

Doubleday, Page & Co.
OFFICES
GARDEN CITY, N. Y.
NEW YORK: 285 MADISON AVE.
BOSTON: PARK SQUARE BUILDING
CHICAGO: PEOPLES GAS BUILDING
SANTA BARBARA, CAL.
LONDON: WM. HEINEMANN LTD.
TORONTO: OXFORD UNIVERSITY PRESS

Doubleday, Page & Co.
OFFICERS
F. N. DOUBLEDAY, President
NELSON DOUBLEDAY, Vice-President
S. A. EVERITT, Vice-President
RUSSELL DOUBLEDAY, Secretary
JOHN J. HESSIAN, Treasurer
L. A. COMSTOCK, Asst. Secretary
L. J. McNAUGHTON, Asst. Treasurer

DOUBLEDAY, PAGE & COMPANY, Garden City, New York

Copyright, 1927, in the United States, Newfoundland, Great Britain, Canada, and other countries by Doubleday, Page & Company. All rights reserved.
TERMS: \$4.00 a year; single copies 35 cents.

A REAL ABUSE TEST

So many people run their batteries up too high that, having made good Radiotrons for careful users, RCA set about to make Radiotrons that would stand abuse.

A year ago, an RCA Radiotron could stand about twenty hours of running under too heavy a current. Now it will outlive a hundred hours of such abuse.

Many very minute changes brought about through laboratory study have effected this improvement.

If you have children who are apt to turn up the rheostats carelessly, of course it is hard on the tubes. No tubes can be proof against ruin, but if you are using RCA Radiotrons, you know at least that they'll stand more than ordinary tubes.

Look for that RCA mark! You'll find it on Radiotrons for every purpose.



RADIO CORPORATION
OF AMERICA
New York Chicago
San Francisco



The stations are there get them!

You're not getting the most out of that storage battery set of yours. The *set* has a bigger distance reach . . . all it needs is a different tube in the detector socket. Put in the RCA super-detector—Radiotron UX-200-A. You'll get more stations—get the far-away ones more regularly and more easily! It's a small change, but it brings big results.

*Bring your storage battery set up-to-date with
a power RADIOTRON UX-171 or UX-112
a detector RADIOTRON UX-200-A*

and RADIOTRONS UX-201-A for all-round quality.

*Bring your dry battery set up-to-date with
a power RADIOTRON UX-120
and RADIOTRONS UX-199 for all-round quality.*

RCA Radiotron

MADE BY THE MAKERS OF THE RADIOLA



THE TOWERS OF STATION WOW, AT OMAHA, NEBRASKA

Formerly known as WOAW, this station has enjoyed a wide national popularity. In April, this station celebrates its fourth anniversary. The illustration shows the hoisting of a large section of plate glass, which now forms the front of a unique studio atop this 19-story building. The studio is arranged as a stage, properly insulated against sound inside, but with a front panel of glass to allow those seated in a small auditorium to watch and to hear the broadcasting as it occurs

RADIO BROADCAST

VOLUME XI



NUMBER 1

MAY, 1927

With MacMillan to the Arctic

Tales from the Pen of the SACHEM's Radio Operator—Not so Stupid, These Eskimo Flappers—Some Notes on the Aurora, Mirages, and Radio—Abe Puts One Over!

By AUSTIN G. COOLEY

TAKING up the threads of our story from where we dropped them last month, we on the *SACHEM* and our friends on the *Bowdoin* find ourselves at Godhaven, Disko Island, the northernmost port of call of the expedition.

Let us deviate a little, though, to tell of the inhabitants of these arctic regions, for an account of an expedition into the land of the Eskimos is not complete without some mention of these most interesting people. Although the full-blooded Eskimos are few and far between, their habits and methods of living are preserved by those who possess considerable Danish blood. They are all wards of the Danish Government and are well cared for, and every effort is made to preserve their native customs and practices.

The Eskimo flappers are not so stupid; in fact, they have many of the same instincts that are common among the American beauties. In the matter of short skirts, they are years ahead of the best of our stenographers. The complete absence of skirts is due in a large measure to the Danish rulings that prevent them from changing from their native custom of sealskin pants and boots. They take great pride in making their boots the most attractive in the settlement. Generally they are dyed with a brilliant white or bright red. The girls all make large bead collars for themselves of their own design, with beads imported from Denmark. Ordinarily it is very difficult to obtain these collars but this year a few were purchased for thirty kroner (Danish money). Many of the girls, if they have considerable Danish blood in them, are quite pretty; otherwise they look too much like Eskimos.

A few of the Eskimos live in small frame houses or shacks while the others have their homes built of sod. These houses, or igloos, are built very scientifically with a selected sod that is a good heat insulator. The walls are built very thick and the doors all have tunnel approaches built of sod, entering at an angle to the door. Each igloo has a bed consisting of a raised platform large enough to accommodate the entire family. The Greenland Eskimos, and the igloos that we saw, were very clean.

Many of the expedition found it great sport trading with the Eskimos for souvenirs, such as harpoons, bird spears, model kyaks, etc. In Sukkertoppen, Mrs. Metcalf wanted to get a model of a woman's skin boat. She asked some of the Eskimos in their language if they had any "coumiaks."

Considerable laughter among the Eskimos immediately resulted. Abe Bromfield, Commander MacMillan's interpreter, had to come to her assistance. It was an "umiak" she wanted. "Coumiak" is the Eskimo word for "lice"!

For exchange, the Eskimos generally wanted tobacco and calico, although some asked for kroner which could be used at the stores run in the large settlements by the Danish government. The Danish money used in Greenland bears pictures of animals, such as polar bears, whales, seals, and ducks, so that the value may be recognized by the Eskimos.

During certain seasons, the Eskimos work in fisheries operated by the Government, and at other times they are busy sealing and hunting. The womens' work includes the chewing of seal skins so as to soften them, and the making of boots and clothing.

Anyone espied walking ashore with a camera was sure to have a large following, for the Eskimo girls are as anxious to have their pictures taken as are some American girls to appear in the movies. When preparing for a shore trip with the cameras, I always considered a supply of gum and cigarettes as important as the films. After taking pictures, these would be passed around to the eager natives, who were especially anxious for cigarettes; even the babies in their mother's arms made manifest a desire to smoke. They seemed to enjoy smoking as much as their grandmothers.

The Eskimo's Santa Claus is more of a fact than a myth. His phase angle displacement is 180 degrees from ours! He comes from the south in the summer time in a white schooner, and brings toys and candy for the bad little boys and girls as



CAPTAIN "MAC" AND ABE

The latter was the Eskimo interpreter of the Expedition. He returned with the others to America when the *SACHEM* and *Bowdoin* came back and, among many other things, saw a train for the first time in his life

well as the good ones. He is known to them as "Captain Mac." Captain Mac's own generosity is always backed up by various candy manufacturers who see that the expedition does not leave American shores without a plentiful supply of all kinds of candy for the natives. The toys distributed by Captain Mac are generally of the nickel and dime variety, but some of the most deserving Eskimo men receive presents of excellent jack knives.

Some of the unfortunate Eskimos receive presents of lemons and a pleasant visit by the expedition's doctor—Doctor Thomas of Chicago. Doctor Thomas treated a number of cases among the Labrador Eskimos and in one instance performed an operation.

At practically all of the settlements at which we stopped, Captain Mac put on movie shows for the natives. The attendance was always one hundred per cent. "Robbie," the mate of the *Bowdoin*, was skilled in packing whole settlements into a small room so as to give each Eskimo a good view of the screen.

WE START OUR TRIP HOME

COMMANDER MacMillan planned on running south from Godhaven, Greenland, to Holsteinborg, then across to Baffin Land, but the problem of replenishing our fuel supply required some changes in the schedule. We went south to a whaling station at Edgesminde where ten barrels of fuel oil were obtained, but this was not enough to take us home. Using the engines seemed more desirable than the sails, so we went further on, to Sukkertoppen, where a larger supply could be had.

This southbound trip included a few days' stop at Holsteinborg, formerly a center for American halibut fisheries. In the cemetery were found a number of graves of Gloucester fishermen. All foreign fishermen are now barred from the coast of Greenland and the Danish Government is operating the halibut fishing industry at Holsteinborg with great success. During our stay at this port, we enjoyed many meals of halibut. It was delivered to the ship at a price corresponding to one cent a pound.

Except for the fog at sea, the weather we experienced in Greenland was of the best. During the day, the temperature generally ran around 70 degrees. This weather, on the middle western Greenland coast, is due to a warm ocean current which prevents the winters from being any more severe than they are in Maine.

Our call at Sukkertoppen for fuel lasted only a few hours. Before leaving, plans were made to set a course for Cape Murchison, Bevoort Island. If the ice was not too heavy, we planned to run up Robinson Sound, between Bevoort Island and Baffin Island, and anchor in a harbor that was dotted in on the chart. The dots meant: "Harbor about here."

The radio conditions during our last few days in Greenland were very poor. Even the powerful commercial stations

faded out completely at times. While going across to Baffin Land it was hardly possible to get through any amount of traffic to the States because of complete fading. Radio 1 AAY (Kenneth M. Gold, Holyoke, Massachusetts) was worked a couple of times but it was only possible to get one complete message of about fifty words from him. Other stations were worked but communications only lasted a few minutes before they faded out completely.

Davis Straits had received considerable publicity as being a "blind spot" because it so happened that short-wave radio communication could not be established from this location on the previous year. On the recent outward trip, Paul J. McGee, the operator at WNP, the *Bowdoin*, succeeded in transmitting to the States a 200-word message when going north through the Straits. At the same time I observed that the signals from the States were coming through with good intensity. Why the conditions on our return trip were so poor seemed to have some connection with the aurora because strong displays of the northern lights were visible as we left Sukkertoppen at 2 A.M. on Friday, August the thirteenth.

On the return trip, both McGee and I seemed to have considerable trouble with swinging waves. When we reached the ice fields off the Labrador coast we were hardly able to get through any communications although, after considerable effort, we exchanged position messages. The ice was fairly heavy but we considered it not too bad to prevent us from making Cape Murchison. About 8 P.M. on the fourteenth, we sighted the cape through the fog about a half mile off.

The weather kept getting thicker and colder and a strong gale came up that increased the danger of navigating these uncharted waters. The harbor where we were to meet the *Bowdoin* was full of ice. The storm became more severe and the night was very dark, so it was considered too much of a risk to try to anchor the ship even though we could find a harbor. A broken reverse gear added to the hazards. The entire crew stood watch that night. We all wore all the clothes we had aboard under our oilskins, together with hip boots so as to offer maximum resistance to the cold rain, sleet, and snow that was driven hard by the gale.

Radio communication was established with radio 1 AAY, and as I was asking him to give our position to the *Bowdoin* if he could, all signals faded out completely. At frequent intervals I called WNP, the *Bowdoin*, but I received no answer.

As the day started to break, two harbors were located. One was well sheltered but we could not get in because the entrance was blocked by a few large icebergs. The other was full of rocks and bergs but, with the skillful handling of the ship, a reasonably safe place was located and then the hook dropped. Dropping the hook was not so easy. The gale was still strong and the water twelve fathoms deep, and we had

to let out about forty fathoms of anchor chain. The last twenty fathoms came out of the chain locker in installments of one and two feet at a time while it was being untangled and untwisted.

Communication was established with WNP that afternoon on a schedule. His wave was swinging badly but I was able to learn his position and that he was headed for Hall Island, near the southern end of Baffin Island. Apparently the *Bowdoin* got the worst of the storm as they stayed at sea and rode it out, for Commander MacMillan considered the ice too heavy to attempt to run into the Sound. The danger of the ice was that, if the wind changed, it might pack in on us and push the vessel on to the beach.

The following morning we pulled in our 40 fathoms of anchor chain and headed for Hall Island.

While passing through the ice, we saw many seals, and after clearing it, walrus were plentiful. After quite an exciting time with artillery, harpoons, and killing irons, we managed to get one of the latter aboard that weighed about 1500 pounds.

Upon arriving at Hall Island that evening, a radio message was received from the Commander advising us that he had gone on and that we should meet him at Saglek Bay, Labrador. At four o'clock the following morning, we started out on this long trip across the Hudson Straits. Fair weather permitted us to make Saglek Bay by six P.M. the following day.

OBSERVATIONS ON RADIO FADING

OUR activities at Saglek Bay deserve considerable mention. The *Bowdoin* had gone up far into one arm of the bay so that the scientists could make a collection of some kind of field mice that exist there. Some of the other boys found sport hunting caribou but they did not enjoy the success the scientists had.

McGee planned on setting up a receiving set ashore that night so that Kennett Rawson, a member of the *Bowdoin* crew, could hear his father who was scheduled to broadcast from WJAZ, Chicago. An elaborate installation was made with the help of "Ken," who was so strong he stretched the antenna wire enough to break it. The heavy equipment had been carried about two miles up into the hills to an "ideal" location. All this work did not even result in a squeal from WJAZ. This was most disappointing as reception in Greenland from this station had been quite successful at times.

During the time that McGee was trying to receive WJAZ, I was trying to receive anyone I could. At times signals seemed fairly good, and then they would fade out completely. Someone informed me that the aurora was quite strong. I went on deck to investigate. Never before had I ever seen such a violent and brilliant display of the northern lights.

At times we were completely surrounded by the bright blue bands of aurora, and streamers from all around the horizon

would shoot up to the zenith, making a complete umbrella of aurora. In places, the bands were fringed with a dark red.

Until making this trip, I felt that no relation existed between the aurora and radio conditions, as I had made rough observations during the part of one winter in Alaska and was able to detect no connections between the two on wavelengths of six hundred meters or higher (500 kc. or less). No one seemed to really know whether any relation existed although some were quite certain that it did and others were more positive that it did not.

An excellent opportunity was offered me to gather some data that might throw a little light on the subject, so I started work, but in a rather crude fashion. My notes consisted of brief descriptions of the aurora together with a log of the stations that were coming through and remarks as to intensity. For three hours I kept running up and down the companionway taking notes on the aurora and then listening to the radio. I was thoroughly convinced after these notes had been gone over that a definite relation did exist between the aurora and radio conditions.

The following night we were at sea, bound for Nain. The aurora appeared in thin bands sweeping across the sky from the northeast. I took data as on the night before. Mr. Warren was at the wheel at the time and noticed compass variations of

five or six degrees as the bands of aurora passed over us.

We were following the *Bowdoin* along the half-charted coast of northern Labrador when our engines stopped. The chief engineer found the fuel pipe lines full of water. A little over an hour was required to take down all the lines and drain about a barrel of water out of the fuel tank that had been filled at Sukkertoppen. The *Bowdoin* was a mile or two ahead of us when we stopped and her lights soon dropped out of sight altogether. There was a light breeze up so we were able to keep clear of the rocks with the use of the sails. Nain was no easy place to find as it was hidden away somewhere among a great conglomeration of islands and bays

not appearing on the charts with which we were supplied.

The following afternoon we ran into an entrance that appeared to be the correct one for Nain. After hours of sailing around islands and into bays that all looked alike, we came to anchor. Commodore Metcalf, the Captain, and the Chief immediately set to chasing a large bear we sighted along the shore.

One time that afternoon, while we were sailing up a wide clear channel at full speed, we hit a rock. The ship lurched a little to one side as we slid over it and went right on. The hull was well built and especially constructed to stand any shock of hitting rocks or running on to ice, so we were none the worse for the mishap.

Locating Nain was no problem for Commander MacMillan on the *Bowdoin* as he knew the Labrador coast equally as well as the streets of his home town, but while originally acquiring his familiarity of the country he tells how he spent two weeks locating this settlement.

The Moravian missionaries here had a motive in locating their station in a place so difficult to find. Before the fishermen began intruding upon this coast, the Eskimos were a strong healthy lot of people making a prosperous living from fishing and hunting. Fighting took place between the Eskimos and fishermen at their first appearance. To protect the Eskimos and



SOME PICTURES TAKEN IN ARCTIC REGIONS

The upper circle shows an Eskimo boy in his kayak at Sukkertoppen, Greenland. The top left "snap" was taken at the northernmost port of call of the Expedition—Godhaven. The Eskimo girls are interested in the camera and are not a bit bashful. The pile of sod in front of them is being dried for use in the construction of an igloo. This material is also used for fuel. The *Bowdoin* and *Sackem* are shown at anchor at the foot of the towering rocky coastline at Godhaven in the top right-hand picture. The inner circle depicts Maude Fisher at the wheel of the *Sackem*, cheerful despite a painfully swollen face caused by Labrador mosquitoes. The *Sackem* is at anchor in Battle Harbor, Labrador, in the lower left-hand picture. The group of three to the right includes: Captain Crowell, skipper of Commodore Metcalf's *Sackem*; Marion Smith; and Maude Fisher

prevent their annihilation, Moravian missionaries from Germany risked and sacrificed their lives for the cause. They have been able to keep the race alive for over a hundred and forty years by their persistent, self sacrificing work. Protection from the diseases of the fisherman has been one of the most important problems they faced, and their station at Nain was hidden away so as to make its approach by the white man very difficult.

In hunting for Nain, Commodore Metcalf had given way to the opinions of others as to where we should head the *Sachem*. His good sense of direction finally won the courage of his convictions when he informed us that we would hoist anchor at five A. M. and arrive at Nain at eight. At 8:20 we dropped the hook alongside the *Bowdoin* at Nain.

In going south from Nain to Battle Harbor, we stopped nearly every night. We had two days at Jack Lane's Bay where Abe Bromfield lived. Arrangements were made to take him to the States for the winter. We were all as much interested in his trip to civilization as Abe himself. Abe had never seen a railroad train, an automobile, a horse, or many of the other things that are so common to us. Just how he would be impressed by all these things was a matter of much speculation on our part.

Some of our stops on the Labrador coast represented agony because of the flies and mosquitoes. At one place I arranged to set up some apparatus for measuring earth currents that exist during aurora displays. I soaked myself with Flit and went ashore to locate a suitable place. The effect of the Flit did not last long. I was compelled to retreat to the ship with all the speed I could put behind the dory I was in. The swellings and itching from the fly bites lasted for days.

In comparison with what the three women who were with us on the *Sachem* suffered from the flies, I had no reason to complain. They went ashore, protected by head nets, but the flies easily worked their way through. Miss Fisher's face was swollen up like a toy balloon while Miss Smith suffered with hundreds of bites but was not affected by such swelling.

I was able to get additional data on the relation between the aurora and radio every night. In addition to the aurora data, notes were taken on the barometer readings and on the mirages that were so common. At times we were able to get photographs of the ice mirages. After reporting to RADIO BROADCAST about the mirages, the editor sent me a message quoting a press report that read as follows: "Captain Rose, of Steamer *President Adams*, at 8 P.M. July 15, in Mediterranean Sea, bound for Port Said, states they saw 'large field of floating ice cakes suspended above horizon and presently a number of small pieces drifted into view followed by a large one. The latter was so clear we could see blue and green veins in the ice.'"

Early in the trip, Commander MacMillan said that if conditions were right, it

would be possible to see mirages of images half way around the earth. Considering light and radio waves to be the same thing, except for difference in frequency, it seemed that there might be some connection between the mirages and radio phenomena.

In the data collected, there appeared to be a rather definite relation between barometric pressure, mirages, aurora, magnetic storms, and radio fading. The data is by no means complete but the observations substantiate the following statements:

1. Mirages and aurora only occur with heavy air pressure.
2. The relation between the aurora and radio fading depends upon the following:
 - (a.) Formation of aurora and its location in respect to the approaching radio wave and the receiving station.
 - (b.) Frequency of the radio signal.

In accounting for the fading, the temperature is an important factor in the formulas already worked out for mirages. A more detailed account of the data and the conclusions drawn will be taken up in a later article.

It might be well to mention here that communication between the *Bowdoin* and *Sachem* was never hampered due to "skip distance" effect. The distance between the two ships varied between three feet and three hundred miles during the trip and we always communicated on waves between thirty-two and forty-two meters (9370 and 7140 kc.).

We found Battle Harbor filled up tight with eighteen fishing vessels, and we were compelled to anchor in what is known as "Outer Harbor." We had prepared to wait there until the mail boat arrived on the following day hoping that a new reverse gear would be aboard for us. According to calculations, the chances seemed very poor and the next boat was not due for two weeks.

The story about the reverse gear, however, displays the efficiency of modern means of communication. The extent of the damage done to the gear which was caused when we ran aground on the Arctic Circle, was not determined until an examination was made at Holsteinborg. A radiogram was sent through on the night of the examination to the offices of John G. Alden, the ship's designers, in Boston. This message was received by them when the offices were opened at nine in the morning. A wire was sent from there to the makers of the gear but not knowing the type used, they wired the builders of the engine in Columbus, Ohio, for this information. By noon a wire was received at the Alden offices from the makers of the gear that a new one had been shipped express, special handling. Only by a margin of a few hours, the gear reached the mail steamer before sailing, and we received it the morning after arriving at Battle Harbor.

It was not until we reached Battle Harbor that I put any broadcast music on the loud speaker for the entertainment of the crew. I held back on the broadcast music because we had an excellent Sonora por-

table phonograph with a large number of records and because the reception up to that time did not have much entertainment value. It was possible to hear broadcast stations faintly as they faded in and out but to try to get them regularly seemed only a waste of time.

I noticed that many of the missionaries in Labrador and governors in Greenland have receivers that had been given them the previous year by Commander E. F. MacDonald. With their large antennas, they are able to hear stations in the States reasonably well in the summer. Winter reception is reported as excellent.

The 63-meter (4760-kc.) signals from KDKA came in well during most of the summer but were subject to bad fading. The 32½-meter (9225-kc.) signals from WGY appeared very steady and fairly strong while we were in Greenland.

BACK TO CIVILIZATION

IF YOU want to find out how great a fine big juicy beef steak can taste, just take a three months' trip into the north and live on canned goods as we did. When we loaded up with fresh supplies on our arrival at Sydney, Nova Scotia, we all ate like wild men. With the crew fed up on red meat, the captain was afraid to let the men handle the lines for fear of breaking all we had.

On the last leg of the voyage before reaching the States, we ran into some very heavy weather off the Nova Scotia coast. Most of us on the *Bowdoin* and *Sachem* experienced seasickness but it did not last long on the *Sachem* as Commodore Metcalf put aboard a supply of "seasick pills" at Sydney which served their purpose nicely. I believe their trade name is "Sea Oxy." This is not a free advertisement—it is sympathetic advice.

Our arrival at Wiscasset on September the eleventh does not end the story. Abe Bromfield has to be accounted for. At Sydney, Abe appeared to be most interested in the railroad whistle and a long train of cars. At Wiscasset, he could not understand why they had small light-houses in the middle of the streets.

Commander MacMillan was engaged to speak at the New York Radio Show. Abe went with him. In a day and a half Commander E. F. MacDonald showed Abe more of New York than I had seen in a year and a half. Abe remembers every detail of this trip, for his memory is remarkable. Reporters all shot the stock question at him: "What do you think of American flappers?" Abe's confidential report is that the Wiscasset girls are much prettier than the ones in New York.

Abe is a great one for shaking hands. I am sure he would enjoy exchanging places with President Coolidge at times. On one occasion, Abe was following Commander MacDonald into the New York Radio Show when the ticket taker put out his hand. Abe shook hands with him. This first attempt at crashing gates was a grand success as the ticket taker almost passed out while Abe walked on in.



THE MARCH OF RADIO

News and Interpretation of Current Radio Events

What Does the Listener Want? Let Him Speak

THE Radio Act of 1927 provides that "the licensing authority shall make such a distribution of licenses, bands of frequency or wavelengths, periods of time for operation, and of power among the different states and communities as to give fair, efficient, and equitable service to each of the same." Licenses shall be issued and renewed only "if public interest, convenience, or necessity are served thereby."

These are the sole bases in the new radio law upon which broadcasting stations shall be distributed and licensed. The criterion, then, by which a station's right to broadcast is to be judged is its service value to the listening public in its own service area and the effect of its operation upon broadcasting in other areas.

What a trail of broken hearts must follow in the wake of that formula! Even now we can hear the groans and lamentations of the disappointed, who have pleaded in vain before the relentless Commission. Here is a reformer, who spent the hard-earned money of generous contributors, to broadcast messages of uplift to an immense aud-

ience, an enthusiastic audience which bought so many of his expensive little pamphlets in the past; we see his bowed form as he staggers dizzily out of the offices of the Radio Commission, realizing that his work of saving the public soul can no longer be continued behind the comfort of the microphone. There is a philanthropic business man who, out of the goodness of his great heart, has spent thousands and thousands of his excess profits to spread gladness and cheer and—advertising, to a receptive public. And here is a little fellow, so he says, who has erected a modest little station, but a nice little station nevertheless, just to make folks happy but, he sobs, the accursed monopoly has bought the souls of the Radio Commission; they get their place in the ether without a struggle; he must put his tubes and condensers back in stock now and sell them to his unsuspecting customers, not without a little free monopoly publicity in the home town paper though, to help him on his way.

Gentlemen of the Radio Commission, let but one voice rule you! The voice of the broadcast listener! Give him fair, efficient, and equitable service! Remember, not one of those who seek to broadcast has anything but a selfish purpose, however disguised, in seeking a place in the ether. Big and little, alike, have something to sell, whether it be

a cause depending upon contributions for revenue, a commodity feeding its sales through goodwill, or a community encouraging capital and population to its territorial limits.

The most important evidence to guide the commissioners in determining what is fair, efficient, and equitable service to the different states and communities will be the expressions of the listening public of their desires. The broadcast listener must become articulate if this wise provision in the law is to have the opportunity to mean what it says.

Already there has been recognition of the necessity for listener organization. We noted, for instance, in a recent issue of the *Northwest Radio News*, the official organ of the Northwest Radio Trade Association, a strong plea that the trade support radio listener organizations. It urges such listener groups to consider questions of receiver operation and repair, to conduct set building contests, to give opportunity for unbiased demonstration of commercial sets and accessories, to criticize, condemn, or commend sales methods and radio advertising, to encourage new uses for radio, to improve radio reception conditions by exposing broadcasting station interference, discouraging radiating receivers, and locating power line leaks, and, most important

The illustration forming the heading shows a general view of the first international radio telegraph station at Alfragide, nine miles west of Lisbon, Portugal. On December 5, 1926, direct high-speed service to London opened. The station will also communicate with East and West Africa, and with South America. The short-wave "beam" is used.

of all, to voice constructive criticism and crystalized opinion on broadcasting conditions.

Listener clubs are successful in a few isolated instances. In Scranton, the Lackawanna Radio Club, two years ago, had forty-seven members. It now has 680 and is growing so rapidly that it expects soon to reach a total of 1500. In British Columbia, the Victoria Radio Club is an active organization and has eliminated serious power line interference with the aid of apparatus and engineering talent paid for out of the club's treasury.

Although listener clubs are likely to attract only the most enthusiastic, if but five per cent. of the listening audience became articulate through such organizations, the problems of the Radio Commission in determining listener sentiment would be immeasurably reduced. Frankly, we are a

little pessimistic about the probabilities of powerful listener organizations because radio is a pastime which does not lend itself easily to group enjoyment. Radio listening is a personal, or a family affair. The membership of camera clubs and automobile clubs, facing similar conditions, is restricted only to the most enthusiastic. But only by extensive listener organization is it possible to ascertain with certainty what the listener wants.

It requires no power of divination to decide that all heterodyning and overlapping of stations must be eliminated but, beyond this, the Radio Commission has little upon which to base its policy. It may designate broadcasting stations so that the maximum number are crowded in the ether bands without interference or it may decide upon the minimum number of stations for each area which give sufficient variety of service,

which leave the widest possible gaps for distant stations, and offer the listener the choice of the greatest possible number of program sources.

RADIO BROADCAST seeks to aid the Commission by securing a definite expression of the station or stations desired by listeners of various areas. We urge our readers to fill in the questionnaire which appears on this page. The questionnaires returned to us will be carefully tabulated and the result will be presented to the Radio Commission for its information.

The expressions of the listening audience, so far demonstrated in a wholly unorganized and spasmodic way, have already shown their effectiveness in securing desired action. When Senators Pittman, Howell, Copeland, and Heflin endangered the passage of radio legislation by their continued wrangling over the bill, listener

Which Stations Shall Broadcast?

THE answers to the few questions below, if answered and returned to RADIO BROADCAST at once, will form the basis for a presentation to the Federal Radio Commission. The Radio Act of 1927 provides that the Commission shall assign licenses to broadcast stations in the light of "public interest, convenience, and necessity." Unless the Commission has some means of determining the feeling of radio listeners in each of the five new radio districts, that task is going to be nearly impossible. The importance of terse, complete answers to the questions below is apparent. If our readers desire to make their wishes articulate, we believe that an answer to these questions will enable us to help them and to aid the Radio Commission.

Please typewrite your answers wherever possible. If you do not desire to cut this page from the magazine, please answer the questions in order on another sheet and mail it to us. Many readers complained when answering the recent questionnaire in "The Listeners' Point of View" that they were loath to cut up their copy since each was carefully preserved. Mechanical difficulties make it impossible to insert this questionnaire in any other part of the magazine.

Please fill in the answers at once and mail to:

The Editor,
RADIO BROADCAST,
Garden City, New York.

Please Answer These Questions

1. List local stations (within 100 miles) you wish retained on the air *in order of your choice*:
2. List favorite stations which are now excluded to you by radio interference:
3. List favorite out of town stations you wish retained:
4. Do you prefer a maximum number of local (within 100 miles) stations to the exclusion of the greatest number of out-of-town stations?
(A.) Yes. (B.) No. (C.) Maximum number of "locals" _____
5. List the stations you wish eliminated, the most unpopular ones first. (Please list present call letters only).
6. What kind of receiver have you? (Please be brief: neutrodyne, tuned r.f., etc.)
7. Name _____
Town _____
State _____
8. Additional remarks and suggestions should be made on a typewritten sheet attached to this questionnaire.

City listeners can answer completely all of the questions in the above list. Those listeners who have no local stations can indicate their opinion satisfactorily by answering all questions except No. 1; it is particularly valuable, however, to have their opinions on No. 4.

protests came in such numbers that these very vocal Senators were forced to capitulate. But there was no truly organized listener opinion represented. Indeed, Senators clutched upon the feeblest ray of evidence to cite listener opinion in support of their various arguments. For example, references appear in the *Congressional Record* to a protest against the Radio Bill made by one C. Wood Arthur, speaking for a so-called Radio League of America. Letters from this magazine addressed to Mr. Arthur have received no acknowledgment or reply. Nor have we been able to learn from any other source who Mr. Arthur represents beside himself. In the absence of a recognized listener organization, anyone, however unknown and unrepresentative, may take it upon himself to influence the course of legislation and the future action of the Commissioners. The lack of organization of broadcast listeners is a menace to their interests, a condition which would be quickly alleviated by the formation of a truly nationwide listener organization.

Objections to the Radio Law

WHILE the Radio Act was the subject of debate in the House and Senate, certain objections were brought to its provisions which, were they valid, would undoubtedly be serious reflections upon the soundness of the Act. It is worth while to consider some of these points lest confidence in the Radio Law be undermined.

The radio listener has every reason to be congratulated on the fine piece of legislation which Senator Dill so ably marshalled through the Senate. We regret, of course, that the original White Bill, which did not provide the cumbersome and expensive radio commission, was not passed, but the ingenious compromise worked out is the best law which could be hoped for. The commission, we fear, is a permanent expense. It will probably remain in session practically all the time even after the first year, since anyone questioning the Department of Commerce's rulings automatically brings his case before the Commission.

Some of the objectors to the bill apparently failed to read it carefully or they have no adequate understanding of the English language. One provision of the Act states that broadcasters cannot acquire or construct wire lines of their own for the purpose of securing unfair advantage over rival broadcasters. Senator Copeland (D. New York) spoke harshly against this provision, stating that the telegraph and telephone companies (against whom this provision is directed) make so much money now out of telegrams sent in response to radio programs that they fear broadcasters might take away this business by means of a communication system of their own!

He also stated that light, heat, and power would "soon be transmitted by radio" and

that, therefore, licenses should not be granted for three years. The Act specifically provides that a station's license may be revoked if it is used for a service differing in any way from that for which the license was granted. This same provision is adequate protection against the transmission of "scrambled" programs for which the listener would be compelled to use a special

a splutter by insisting that, as soon as the "interests" were licensed under the new Act, they might begin transmitting scrambled programs, so that the listener would have to pay for them or else junk his set. Such transmission could not be undertaken without express permission of the Commission, which would be derelict in its duty if it granted that permission without public demand for it.

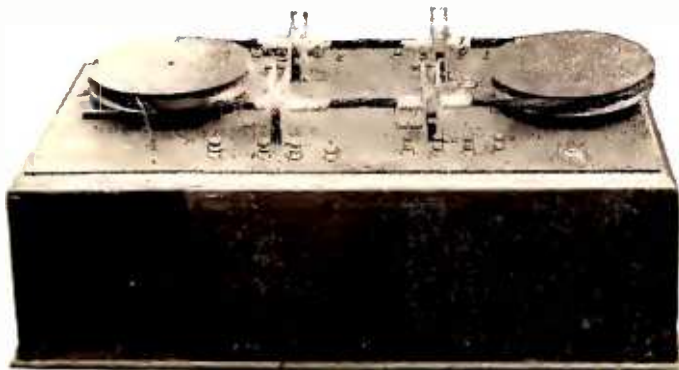

THE ORIGINAL MAGNETIC DETECTOR
USED BY MARCONI

patented receiver. The Commission has full power to limit and prescribe the kind of equipment to be used in transmission. Fortunately, no specific barrier to charging for programs was incorporated in the law because it is quite conceivable that there may, some day, be demand for high-grade programs for which the listener might be asked to pay. On the other hand, such a private service could not be undertaken, under the Act, if it did not meet the requirement that it was fair and equitable service to the listener. One Representative created quite

The Question of Vested Rights

THE only serious criticism of the Act in the Senate centered upon the point that no declaration was made in the law to the effect that the ether is owned by the people. The law ignores the matter of ether ownership but asserts unequivocally the full power of the government to regulate its use. Ether ownership is a subject of considerable legal complexity, since we cannot accurately define what the ether is. The "ether" is international

and hence cannot be owned by any one nation or any individual. If the ether were considered as "property," divestment of a station of its frequency would automatically make it a matter of property confiscation. As a matter of fact, had broadcasting stations, by any legal interpretation, possessed vested rights prior to the passing of the Radio Act, the mere statement by Congress that they did not possess such rights would not automatically dissolve them. The inclusion of a declaration of ownership of the ether by the people would have in-



TWO WELL-KNOWN RADIO EXECUTIVES

Powel Crosley, Jr., President of the Crosley Radio Corporation, and his newly appointed assistant, R. H. Langley. For the last six years, Mr. Langley has been in charge of receiving set development for the General Electric Company and is widely known in radio engineering circles. The first American airplane transmitter is credited to Mr. Langley

volved the law in precarious legal entanglements. Confinement of the Act's scope to regulation of any and every device using ether waves in no way jeopardizes or weakens its effectiveness. If you have entire control of the use of a thing, its technical ownership becomes of minor importance. If the government can prescribe when, where, and for what purpose you may use your motor car, it, in effect, can exert all of the advantages of complete ownership.

Legal experts state that a vested right could be secured to a wavelength, provided unrestricted ownership had been exercised for a period of many years. In historic covered wagon days, a prospector had only to stake out his claim and to occupy his property to obtain a good title to it. His occupation and improvement thereof eventually gave him legal possession. Complete possession and utilization, without existence of any rights conflicting with it, might in time bring about the establishment of a vested right to a radio frequency. But no such condition obtains with respect to broadcasting frequencies. The right of the government to regulate interstate radio communication is clearly given in the Constitution and the government asserted and exercised that right long before the first broadcasting station went on the air. No broadcasting station at any time has operated without first securing a government license and, in so doing, it has recognized the government's power to regulate the use of the ether.

Undoubtedly there will be efforts on the part of disgruntled stations to prove that their investment in radio transmitting equipment is, in effect, confiscated if they are not allowed on the air. They will therefore demand compensation as is guaranteed under the Constitution when private property is confiscated. But they will be wasting their time and money in seeking compensation because the government's power to revoke a license for the general good, even if it involves depreciation or destruction of private property, has been abundantly established by endless court decisions. One need only recall the actions brought many years ago when local option closed saloons. Although a license to sell intoxicating liquor was property so tangible that it could be sold, mortgaged, and subjected to execution, the courts decided that a license to sell liquor is not a vested right and the state could, in the exercise of its police power, revoke it. Revoking broadcasting licenses is not different. Although revocation of a license may involve making a radio transmitter valueless, the license is nevertheless subject to revocation for the good of the people as a whole. It is extremely unlikely, particularly since broadcasting stations were officially warned that the ether lanes were overcrowded, that any of the existing stations whose licenses must be revoked will be able to obtain compensation on the grounds of confiscation.

We are indebted to the Hon. S. H. Rollinson, an eminent New Jersey lawyer, who has made a thorough study of the legal



B. L. SHINN

New York City

Associate Director, National Better Business Bureau. Especially written for RADIO BROADCAST:

"Many radio firms as well as radio dealers and manufacturers have written to the National Better Business Bureau to express appreciation of its work in promoting the accurate retailing, advertising, and selling of radio storage batteries. This appreciation is most welcome, and in acknowledging it, I take the occasion to point out that this is but one of a number of instances in which the Bureau has worked out, with the engineering and advertising leaders in the radio industry, methods of selling, which have assisted the public to obtain accurate and dependable facts regarding radio products. Even the woods appearing on exposed surfaces of radio cabinets and consoles are now accurately described by most manufacturers, instead of by only a few, because of the activities of this Bureau.

"The Better Business Bureau's service to industry and the public, however, is by no means limited to radio. There is scarcely an important item of merchandise in your home in whose advertising, branding, and marketing the influence of the Bureau's recommendations are not felt. If you have saved money for investment, the National Better Business Bureau and forty-three local Bureaus stand ready to supply reliable and disinterested information upon the security which you are considering."

aspects of the broadcasting situation, for other examples of a governmental police power, the exercise of which has involved what amounts to, but is not, confiscation of property. The State of New Jersey passed a law prohibiting the use of repeating firearms capable of firing more than two shots. This rendered useless repeating rifles possessed by many sportsmen and, in the legal action which followed as a result, brought by sportsmen and manufacturers of firearms, the state proved its complete right to regulate the matter of firearms under the law. Likewise, the government may or

may not grant charters to national banks, as it chooses. If it does not consider it in the public interest to license an additional national bank in any locality, it need not do so. It is empowered to revoke the charter of a national bank in the public interest. A reckless automobile driver may have his license revoked in the maintenance of law and order, even though, in effect, it makes a valuable and expensive piece of property useless to him. The regulation of the ether is a police power which cannot be overthrown upon any grounds of vested rights and cannot be hampered by demands for compensation. We are convinced that the actions brought by broadcasting organizations for compensation or broadcasting rights will be unsuccessful, unless and only if they can show that failure to license them is denying the public fair, efficient, and equitable radio service.

The case of the disgruntled broadcasting station must be overwhelming proof that closing it down is contrary to the public interest. The personal desire of those maintaining the station is of absolutely no value under the law. The Radio Act of 1927 has wiped the broadcasting slate clean for the Radio Commission. At this writing, no broadcasting station is licensed for more than sixty days. Let the Commission have courage! The vast majority will support it to the limit in its difficult task of reducing the number of broadcasting stations by at least sixty per cent. A noisy and selfish minority will always oppose and criticize it. Let the clamoring be outweighed by an organized and powerful listener sentiment and there will be no difficulty in deciding what is meant by fair, efficient, and equitable radio service.

"Christian" Mud Throwing

WE WERE pleased to receive a complete disclaimer from the Christian Science Mother Church in Boston, stating that the destructive propaganda sent out by WHAP in New York is in no way sanctioned by and does not in any way represent the views of that organization. Station WHAP has used its broadcasting station to disseminate large quantities of mud, trained largely against Catholicism. The action of WHAP has disgusted listeners of every shade of religious belief. Broadcasting, fortunately, has been very largely free of intolerance, every kind of religious belief having free access to the microphone to spread its thought constructively. Broadcaster WHAP, disregarding its obligation to the diversified radio audience, has chosen a course of intolerance and villification. Its attacks on Catholicism can not be condoned, and tend to undermine the faith of impressionable persons in any religion. For the good of radio, let us hope that it will no longer be used as a means of breaking down anyone's belief, be it Catholicism, Protestantism, Buddhism, Christian Science, or atheism. A cardinal virtue of Christianity is tolerance. No doubt we will be suspected by intolerant WHAP of being subsidized by the

Pope, but this item is written by a non-Catholic who resents, as do all liberals, the besmirching of any religious belief, his own or some one else's. Let us have no more of WHAP.

A New Term for "A. C. Supply" Units

THE National Better Business Bureau has endorsed the use of the term "socket power unit" to describe devices for the purpose of furnishing A or B power for radio sets. The term "A eliminator" or "B eliminator" is declared as obsolete as the term "horseless carriage," which was at first applied to the motor car. "Socket power" may be applied to describe devices employing combined storage batteries and chargers, thus powering the set indirectly rather than directly from the light socket. It thereby covers the numerous trickle charging storage battery combination units now being so widely sold. We suggest the general acceptance of a term such as "electric set" in order that one may differentiate between receivers using trickle charger—storage battery devices and those powered directly from the light socket through filtering devices without the aid of a secondary battery.

Our attention has been called to advertising, having wide publication, describing A battery devices which "banish the storage battery forever," "eliminate A battery troubles," and similar claims. Investigation has proved that these devices frequently comprise storage batteries combined with trickle chargers. The implication of these phrases in advertising is that the device eliminates the storage battery. Combination trickle chargers and A batteries reduce maintenance attention to a very desirable minimum but we believe the declaration that they completely eliminate it is both exaggerated and misleading.

There Are No Radio Engineers

FROM D. A. Johnston of New Britain, Connecticut, we receive a comment on our item in a previous issue, urging that the education of radio engineers be better balanced with respect to economic and commercial phases of their work:

"Insofar as radio engineers are concerned, I am not quite convinced that there is any such thing. Engineering is very nearly an exact science and an engineer should be able to tell on paper what his product will do so that another engineer can tell exactly whether his product is better or not. Did you ever see any firm producing radio apparatus who would give you information comparing to that which you would expect in buying an electric motor? For example, how many engineers working on sets know what the curves of their particular set look like? I doubt if many of those producing simple articles like battery chargers do know what actual efficiency is. The few who do know these things are not sufficiently satisfied with the product to be willing to say much about them."

This comment is often made by engineers in fields better established than radio. The



EDWARD E. SHUMAKER

New York

President of the Victor Talking Machine Company:

"The question as to who is to pay for radio broadcasting appears to have been temporarily solved. The bills are being met by those who benefit directly from it. While I do not believe that the broadcasting of radio entertainment can be made to take the place of other established forms of advertising, it is an additional medium for creating demands for some products, and a good-will builder when properly used. We have found that the broadcasting of Victor recording artists results in an immediate and traceable demand for their records. We are convinced, also, that anything we may do to raise the standards of radio programs will be reflected in a healthier condition in our business and in other branches of the music industry.

"Radio and the talking machine may at times appear to overlap somewhat. In actual practice they do not overlap. Each has its own place as an instrument for home entertainment. This is borne out by the experience of more than 6000 Victor dealers in the United States. It is also a fact that thousands of new talking machines which are not equipped with radio receiving sets are being sold annually in homes which also contain radio sets.

"In 1924, and the early part of 1925, when the talking machine industry was at a low ebb due to its failure to improve its products, the general impression was that recorded music was being replaced by radio broadcasting. Subsequent developments have demonstrated clearly that such was not the case."

fact is that we have no standardized method of rating the efficiency or selectivity of receiving sets, which nets down to a figure of merit of standardized valuation.

A Survey of Radio Conditions

RADIO RETAILING has issued a report on the broadcasting situation based upon telegraphic summaries from 21 cities, scattered throughout the United States and Canada. Washington, District of Columbia, and Portland, Oregon, were the only two districts re-

porting satisfactory conditions, but it was noted that almost every center of population has one or two high-grade stations which are not being interfered with seriously. The most enterprising leadership in handling the situation was demonstrated on the Pacific Coast, where the Pacific Radio Trade Association not only secured pledges from broadcasting stations that they would abide by the district radio inspector's decisions as to changes in wavelengths, but exerted strong influence in having them observed. Twenty-five per cent. of the midwest stations conflict with local wavelengths in San Francisco on sets of average sensitiveness. From this report and other sources, we learn that among the important stations seriously heterodyned are KOA, WCCO, WOR, WEAJ, WTAM, WHN, WEEI, WNAC, CKCL, and KFKX. *Radio Retailing* is to be congratulated upon the excellence and thoroughness of its survey.

The Month In Radio

THE sales of combination radio and talking machine instruments made by the Victor Company during 1926 had a retail value of something over seventeen million dollars and amounted to one sixth of the total business of the company.

FROM Mr. C. R. Cuchins, Vice President of the First National Bank of Bessemer, Alabama, we learn that the Birmingham *News* decided, upon suggestion from broadcast listeners who forwarded copies of RADIO BROADCAST's editorial on the subject, to resume running radio programs in its columns in a manner which makes them intelligible to the listener.

PORTLAND, Oregon, has passed an ordinance making it unlawful to operate without a permit any apparatus generating high-frequency oscillations which interfere with broadcast reception. Violet ray machines, quenched spark devices, and X-ray machines must be licensed and may not be used, except in emergencies, between the hours of seven and eleven. Power interference, being a local matter, appears to be suited to local regulation.

A NEW transmitter for WEAJ will be erected at Bellmore, Long Island. Bellmore is on the south shore of Long Island, the nearest towns being Freeport, Hempstead, and Farmingdale. An advantage of this location is the relatively small population which suffers from proximity to the station and the fact that the new station will impress the strongest signal where ship interference is most likely to mar its programs. Plans for the new station have been drawn by Dr. Alfred N. Goldsmith, Chief Research Engineer of the Radio Corporation of America, Dr. E. F. W. Alexanderson, of the General Electric Company, and Frank Conrad, Assistant Chief Engineer of the Westinghouse Company. This station may be in operation by October, 1927.

RADIO beacons have been installed at McCook Field, Dayton, and at the Detroit Ford airport for the guidance of the Stout-Ford commercial airplane between those two points.

The Electrical Phonograph

A Non-Technical Explanation of the Principles Involved in Electrical Recording and Reproduction—The New "Panatrope" and "Electrola"—Data for the Home-Constructor Wishing to Build His Own Electrical Phonograph

By

JAMES MILLEN



RADIO BROADCAST Photograph

THE "PANATROPE"

An entirely electrically operated phonograph. Provision is made so that the amplifier system, including the baffleboard loud speaker, may be used for radio purposes after the detector in any radio circuit. This photograph was taken in the RADIO BROADCAST Laboratory

A MOST fascinating experience for one interested in radio—especially one who has long been connected with its development—is to spend an evening with the early issues of some of the older radio magazines.

A study of the advertisement section not only recalls the queer contraptions that were looked upon in their day as the acme of engineering perfection, but also throws light upon the founding and first products of small companies, regarded now as leaders in the radio industry. Not only do large things often develop from a humble start, but also large concerns of one decade often pass into oblivion by the next.

Aside from this, we may also read what the "prophets" of but just a few years ago outlined for the future of the radio industry. For instance, in the November, 1922, issue of this magazine, appeared an article entitled: "Will Radio Replace the Phonograph?"

Apparently there existed some doubt in the mind of the public as to whether the new novelty, radio, could ever reach the "perfection" of the phonograph as regards tone quality, service, and reliability. Now, on the other hand, there appears to be some doubt in the mind of the public regarding the same question, but from a different angle: "Can today's phonograph compete with the radio in tone quality, service, and reliability?"

But, why not, from comparisons of the two, draw one's own conclusions? It is not at all a difficult or costly task to construct a truly fine electric phonograph. Before going into the construction of such devices, however, let us first find out just what this new instrument, known commercially as the "Panatrope" and "Electrola," really is, and just how it works.

The grooves in a phonograph record are so cut as to cause the needle to vibrate from side to side. In the old phonograph these transverse vibrations of the needle were conveyed mechanically by a system of multiplying levers to a mica diaphragm located at the small end of a horn. The vibration of the needle caused vibration of the diaphragm which set the air column in the horn moving, and thus produced sound.

Such a system, while low in manufacturing cost and reliable in operation, resulted in considerable distortion. The horn was resonant at certain frequencies and the diaphragm at others. Thus some notes were greatly over-emphasized while others were entirely missing.

The new electric system depends for its operation upon the vibrations of the needle to produce a constantly varying electric voltage. The minute electric voltage generated by the movement of the needle is amplified by a high-quality audio-frequency amplifier, such as is a component part of the better radio sets, and then converted into sound by a loud speaker.

While the new phonograph will play the old records, the results are not the same as when the new Orthophonic (correct-tone) type records, made especially for the purpose, are used. In former years, records were made mechanically by a machine much resembling the old-style phonograph, into the horn of which orchestras played while closely and uncomfortably huddled together.

Now, however, studios much the same as those of modern broadcast stations, are employed for record making. Standard radio microphones, as many as needed, are so placed as to properly blend all the instruments of even a large symphony orchestra. No longer must the player in front play softer than natural in order not to "drown out" those in back. Everyone plays as if giving a regular recital, and the various micro-

phones are so placed as to produce the proper results.

In fact, the output of the electric phonograph, when one gets right down to the matter, is but a standard broadcast program which, instead of being sent over the air, is recorded and delivered to the consumer without picking up static, heterodyne whistles, and other disturbances en route.

The acoustical difference between the same piece played by the same orchestra over a high-grade broadcast station on a quiet night and played on an electric phonograph, is nil, assuming, of course, that the same quality audio-frequency amplifier and loud speaker are used in both instances.

With these improvements, and one other—the elimination of the record scratch—the modern phonograph becomes a highly desirable companion to the modern radio receiver. Static and sos signals no longer need spoil an evening's entertainment. Favorite selections, beautifully rendered and reproduced, are available at a moment's notice when the radio program is not tempting.

Even the inconvenience of constantly changing records seems soon to be done away with according to recent announcements, of some of the leading phonograph concerns.

But do not understand this article to be an argument in favor of the phonograph over the radio. The phonograph can never take the place of the radio. First, the radio brings news and entertainment into the home as it is actually occurring—banquets, speeches, sporting events and many others; and second, radio supplies its own program; its *repertoire* is not limited by the number of records in the album.

But, as a companion to modern radio, there is a distinct service to be performed by the electrically operated phonograph.

THE NEW PHONOGRAPH

BEFORE considering the re-vamping of the old-style phonograph, perhaps a brief semi-technical description of the "Panatrope" or the "Electrola" may not be amiss. In order to make such a description more clear and to better "tie it up" with what is to follow, the complete device will be divided into its various sub-units.

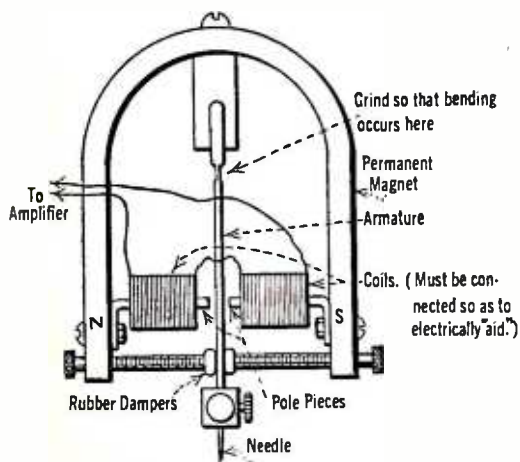

FIG. 1

Details of a home-made pick-up. It consists essentially of a permanent horse-shoe magnet, an armature, and two small electromagnets. The armature is reduced in cross section at its upper end by grinding. The purpose of this is to provide a hinge-like action at this point

First there is the turntable upon which the record is placed. As all of the present models are designed solely for a. c. operation, the motor employed to drive the turntable is generally of the induction type, which, due to lack of the sparking brushes and commutator of the motor, will not cause any pseudo static disturbances in the loud speaker.

Then there is the pick-up, which converts the mechanical vibrations imparted by the record to the needle into electrical impulses.

As will be seen from Figs. 1 and 2, the pick-up consists of a permanent magnet, to which is bolted two pole pieces, two small electromagnets, and a movable armature. Movement of the armature, at one extremity of which is located the needle, results in a variation of the electromagnetic flux passing through the cores of the electromagnets.

This variation in flux induces a varying or alternating voltage in the coils of the electromagnets. The home constructed pick-up illustrated in Fig. 1 clearly indicates the form of construction employed in several high-grade units. Some commercial pick-ups employ variations of the design, such as the use of but one coil, that coil being wound on the armature rather than the pole pieces of the permanent magnet.

Although but few readers will have the facilities for making their own pick-ups, a brief description of an electromagnetic unit should prove interesting to even those who intend purchasing a unit.

A pick-up, as will be seen from Fig. 1, consists of a special shape and size horse-shoe type per-

FIG. 2

The circuit diagram of the "Panatrophe." The purpose of the five tubes employed is as follows: The two UX-216-B's are wired to form a full-wave rectifier system. The UX-876 is a ballast tube connected in the a. c. line to compensate line voltage variations. The UX-199 is the first stage audio amplifier while the UX-210 is a power output tube—the second audio stage

manent magnet to the ends of which are attached pole pieces carrying coils of fine wire. Between the pole pieces is the reed, or armature, which carries the needle.

The permanent magnet should be made from tool steel, cut, drilled, and formed, before being hardened. The larger the cross section of the magnet, the more volume, within limits, that will be obtained from the pick-up. An excessively large magnet will press too heavily upon the record. To magnetize, when a magnetizing machine is not available, wind about a hundred turns of heavy cotton-covered wire around the steel horse-shoe and connect the ends of the wire across a six-volt storage battery for a few minutes. Fewer turns of wire than specified will draw an excessive current from the battery.

The pole pieces and coils may be taken from a radio headset. The headset should be of fairly high impedance and good make.

The armature should also be made of hardened steel, and may either be pivoted or spring mounted. In order that there may be no sustained res-



RADIO BROADCAST Photograph

THE "MEROLA" PICK-UP

An adapter makes possible the use of this device in combination with any good quality amplifier. Merely plug the adapter into the detector tube's socket in the receiver and connect a second lead to the B battery 45-volt post

onance effect from the armature or reed, it is necessary that it should be mechanically damped. The greater the mass and stiffness of the reed, the greater must be the damping if transient free vibrations are to be quickly checked. The elasticity can be made very small by pivoting the reed, but if the mass is too much reduced, the sensitivity is lowered by the consequent reduction of the iron circuit. Rubber may be used for damping.

Proper adjustment of the completed pick-up is important. The faces of the two pole pieces and the armature must be parallel. The armature must be centered between the pole pieces, and the pole pieces must be as close together as possible without danger of the armature hitting. Damping should not be greater than necessary.

ELIMINATING NEEDLE SCRATCH

ASIDE from tone quality, one of the outstanding achievements of the new phonograph is the elimination of surface noises and needle "scratch." The use of a new material for the manufacture of records has done much to eliminate this annoyance of the past but the final and complete elimination is accomplished by means of an electrical filter circuit so tuned as to suppress frequencies in the neighborhood of the scratch frequency. Such an electrical filter is quite simple,

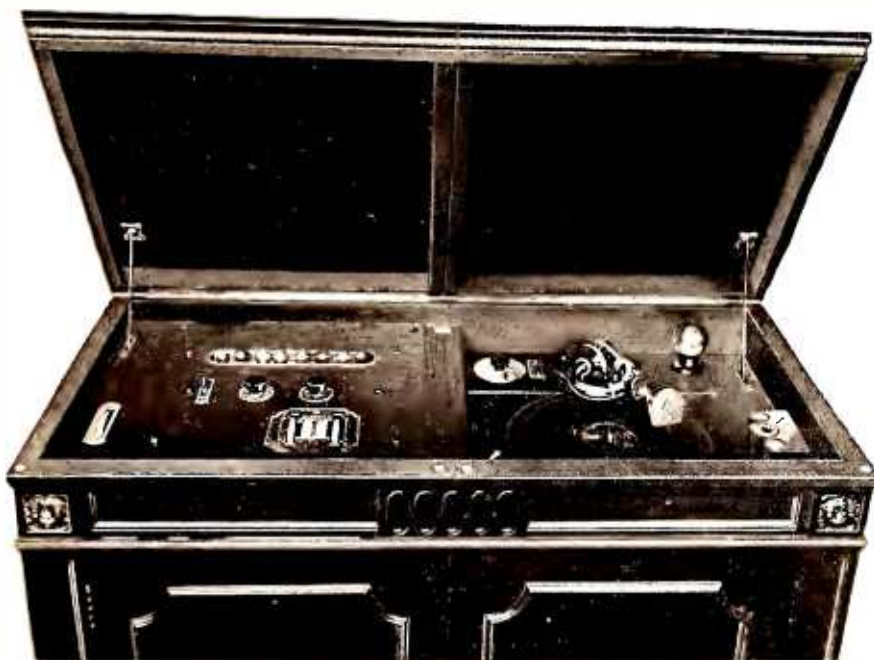

A COMBINATION OF RADIO AND PHONOGRAPH

Representing the ultimate in luxury so far as home entertainment is concerned. This "Electrola" retails for a sum not considerably below a thousand dollars. The reproduction from the records is by electrical pick-up, electrical amplification, and a cone loud speaker

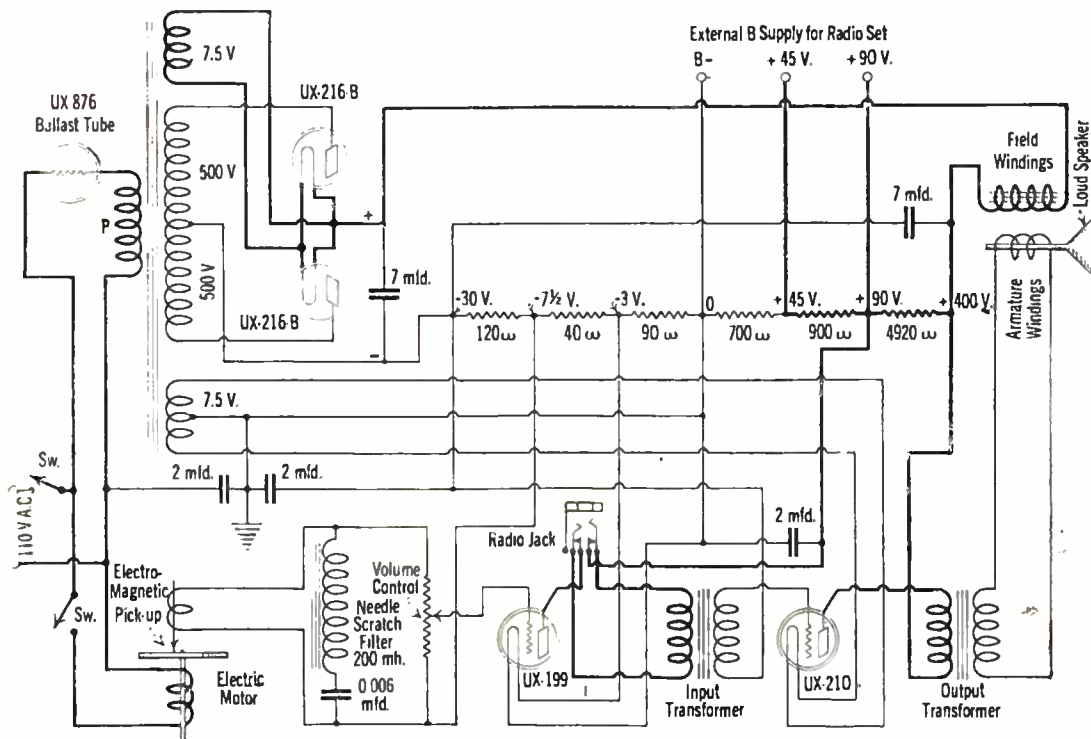



RADIO BROADCAST Photograph

THE GRIMES PICK-UP

An excellent example of the electro-magnetic type of pick-up

as will be seen from Fig. 3, and is connected between the pick-up and the amplifier. The filter is so located before, rather than after the amplifier, in order to prevent unnecessary overloading of the amplifier.

The volume is controlled by a wire-wound potentiometer which permits the audio-frequency voltage supplied to the amplifier to be made any desired fraction of the pick-up output.

The amplifiers employed in the present commercial models of the electric phonograph operate entirely from a. c. The circuit, as will be seen from Fig. 2, comprises a stage of voltage amplification, using a UX-199 tube with filament lighted from rectified a. c., and a stage of power amplification using a UX-210 tube with filament lighted from raw a. c. This power tube is supplied with a potential of close to 400 volts, and the requisite negative grid bias. Transformer coupling is employed between the two stages of amplification as well as between the amplifier output and the loud speaker.

The power supply, which is the same as that employed in the RCA-104 loud speaker, embodies several unique features.

First, a line ballast tube is employed to compensate variations in line voltage so as to prevent changes in filament current of the 199 tube, and to adapt the complete phonograph to power lines of various voltages located in different sections of the country.

Second, the field winding of the baffleboard

type of Rice-Kellogg cone loud speaker is used as the filter choke for the B supply.

Third, the necessity of a ground connection is eliminated by the use of a 2-mfd. condenser between one side of the 110-volt line and the center-tap of the power tube filament winding. In inserting the 110-volt plug in a socket or other outlet, the plug should first be tried one way and then the other as best results are generally secured when the grounded side of the line is the side to which the condenser is connected.

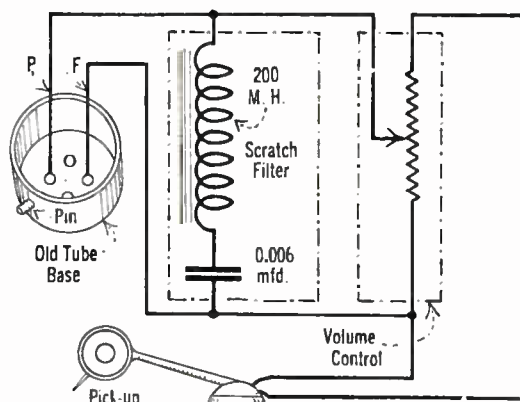

FIG. 3

The electrical connections of the pick-up, scratch filter, volume control, and adapter. The scratch filter as shown is tuned to approximately 4600 cycles

A special input jack makes the amplifier—loud speaker unit available for operation directly from the detector output of any radio set, or better yet, a small two- or three-tube set, such as the two-tube R. B. "Lab." receiver, described in the January RADIO BROADCAST by John B. Brennan, may be built just for the purpose.

Terminals are also provided on the phonograph for supplying B power to the radio receiver.

The loud speaker, as already mentioned, is of the cone type and is electrically "tied into" the amplifier due to the use of its field winding as a filter inductance.



RADIO BROADCAST Photograph

THE HANSCOM "SUPERUNIT"

This pick-up is constructed from a Baldwin phone unit

PICK-UPS

THERE are at least four different types of pick-ups. The electro-magnetic and the crystal types function by generating voltages, while the condenser and the carbon forms operate by variations of impedance.

Of these four, the only one of commercial importance, and, it would seem, the most practical, is the electromagnetic form. To this class belongs those used in the "Electrola," "Panatrope," and the "Vitaphone." This latter is in reality a special electric phonograph designed for synchronization with a motion picture projector.

One of the large corporations interested in the development of radio is experimenting with a pick-up of the crystal type but as yet this unique device is still in the experimental stage.

Pick-ups of the carbon type have been in existence for a number of years but only recently has one capable of high-quality reproduction been perfected. This is the "Bristophone," shown in a photograph on page 23.

This pick-up, which depends for its operation upon the change of its electrical resistance with vibrations of the needle, is in a somewhat different class than the others as it is designed to operate a loud speaker without the use of an amplifier.

Some pick-ups are made of the same parts as used in the construction of an ordinary radio type head telephone. That such should be the case is quite reasonable, for the function of the pick-up is exactly the reverse of the loud speaker unit or telephone receiver.

Generally, however, such devices tend to over-emphasize certain notes and, unless used in connection with a "trick" amplifier, will sound "flat." An exception is the unit from the Western Electric 540 AW cone loud speaker. This unit can be converted into a very fine, but needlessly expensive, pick-up. One of the tricks to such a conversion is the counter balancing of the tone-arm so that the unit, which is quite heavy, does not press too hard on the record.

As a rule, however, for best results, a unit designed from the "ground-up" as a high grade pick-up should be used. Several units of this type are now being manufactured.

USING A PICK-UP WITH ANY SET

BY REMOVING the base from an old 201-A tube (this may readily be accomplished by heating over a gas flame to melt the cement in the base and the solder on the prongs), and connecting the leads from a pick-up to the plate and filament prongs, as shown in Fig. 3, the home-made pick-up shown in Fig. 1 may be used with the amplifier in any radio set. Merely remove the detector tube and in its place insert the "adapter." Fig. 3 also shows the inclusion of a scratch filter and volume control.

The audio amplifier channels of many radio sets in use to-day are so poor as to make such a system of using the pick-up most undesirable. There is little good in purchasing or constructing a pick-up for obtaining the same quality from a phonograph as from a radio set if the audio quality of the radio set is poor.

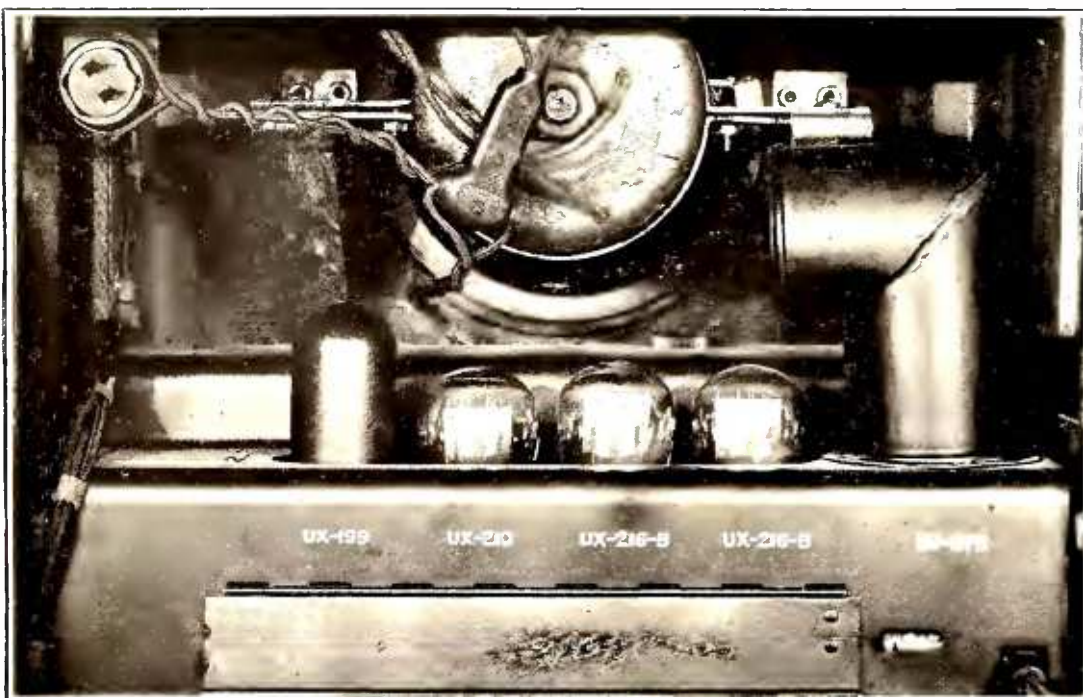

RADIO BROADCAST Photograph

WITHIN THE "PANATROPE"

The rear of the baffleboard loud speaker is seen in the center of this picture. A metal funnel is placed over the UV-876 tube to deflect the heat



RADIO BROADCAST Photograph

A HOME-CONSTRUCTED PHONOGRAPH-RADIO COMBINATION

Built by the author. A more detailed description of this particular instrument is scheduled to appear in RADIO BROADCAST for next month

A desirable thing to do is to construct a new high-quality lamp socket operated audio channel of the type described by the writer in recent issues of RADIO BROADCAST so as to secure well nigh perfect phonograph and radio quality.

Where the amplifier in the radio set is to be used with a pick-up, the following essentials of good quality should be kept in mind:



RADIO BROADCAST Photograph

THE "BRISTOPHONE"

A pick-up of the carbon type which operates a loud speaker without using an amplifier

1. Use of high-grade coupling mediums. The use of the new large-size audio transformers, resistance coupling, or impedance coupling, is to be recommended.

2. Use of a power tube in last audio stage with proper B and C voltages to prevent overloading.

3. Use of an output device. Inductance-capacity units are, in the author's opinion, preferable to the transformer units.

4. Use of a high-grade loud speaker.

SCRATCH FILTERS

WHILE an electrical filter circuit of the type indicated in Fig. 3 will remove all objectionable scratch from the music issuing from the loud speaker, it will not prevent one hearing the un-amplified scratch noise directly from the record. For this reason the lid of the turntable compartment should be kept closed while records are playing.

A high-resistance potentiometer, such as the Centralab or the type L Electrad Royalty unit, makes a very excellent volume control, when wired as indicated in Fig. 3. As a rule, it will generally be found rather convenient to mount this volume control on a small square or disc of bakelite in the turntable compartment of the phonograph. This same panel may also well contain the amplifier control switch.

To get the full benefit from a home-constructed electric phonograph, it is essential to use the new electrically cut records and a good loud speaker of the cone type. Of course the pick-up and amplifier must be good, but generally, after devoting much attention to them, the final results are spoiled by failure to use a good loud speaker.

In the June RADIO BROADCAST, details of a console phonograph cabinet in which a two-tube R. B. "Lab" receiver, baffleboard loud speaker, and lamp-socket powered amplifier with record pick-up, will be described. Data on the construction of a special amplifier, entirely lamp-socket operated and designed primarily for use with a pick-up device, will also be given.



RADIO BROADCAST Photograph

A VIEW OF THE TURNTABLE COMPARTMENT OF THE BRUNSWICK "PANATROPE"

This picture shows the magnetic pick-up arm to the right, the "start-stop" switch at the left, and the volume control above the switch. An induction type of motor turns the turntable, making the operation of the "Panatrope" completely electrical

A Balanced Short-Wave Receiver

A Description, by the Designer of the Best Receiver Submitted in Radio Broadcast's Recent Contest, of a Short-Wave Receiver That Won't Radiate

By FRANK C. JONES

Amateur Station 6 AJF

THE short-wave receiver described by the author in the September, 1926, issue of RADIO BROADCAST was an effort toward the design of a short-wave receiver which would not radiate and interfere with other near-by receivers. Although it had many desirable features, it was not as sensitive as a standard short-wave receiver. The receiver described in this article is the result of further experiments and calculations carried along the same lines. If made carefully, it does not radiate at all and is, in the author's opinion, just as sensitive as the ordinary carefully built short-wave receiver. The improvement over the first receiver described is considerable; in fact, there is no comparison between the two, both as to non-radiating qualities and sensitivity.

The receiver, as shown in the accompanying pictures, was a model built up after the circuit was conceived and not in its final form, since a thorough job of shielding had not been done when the photographs were taken. Imperfect though the photographed receiver was, it was possible to copy New Zealand amateurs on a second receiver while this incompleting one was connected to the same antenna and ground system and permitted to oscillate on the same frequency as the distant station. No interference whatsoever was apparent from the oscillating set during the reception of the New Zealand stations. The writer has never seen any other short-wave receiver which could approach that mark for non-radiating qualities. When listening to the same New Zealand station on the balanced receiver described here, the standard receiver could not be tuned to the same frequency without absolutely swamping everything with its whistling. In fact, it would ruin any attempt to receive anything except a local station when it was oscillating on the same frequency as the received station. Capacity coupling to the same antenna was used by both receivers, one being the balanced and the other a standard Reinartz receiver.

The circuit of the balanced receiver is shown in Fig. 1, and, as can be readily seen, is a form of Wheatstone bridge. It is absolutely necessary to use some form of a bridge with the antenna and ground across zero potential points of the oscillating circuit or circuits. In Fig. 1, the midget

coupling condensers, C_1 and C_2 , form the two capacitive arms of the bridge and L_1, C_3, C_8 and L_3, C_4, C_7 form the essential arms on the other side of the bridge. Both of these latter arms are tuned simultaneously to the same frequency, *i.e.*, that of the incoming frequency and plus or minus say 1000 cycles for heterodyning purposes, and C_1 and C_2 are left set in a certain relation to each other. C_8 is a resultant capacity from the combination of C_3 and the grid-filament capacity, C_g . The condensers C_3 and C_4 are on the same shaft and should be exactly similar so that the two circuits will be tuned to the same frequency or wavelength at any point of the tuning scale. The tickler coils, L_2 and L_4 , are coupled inductively to their respective coils, L_1 and L_3 , in the proper phase relation to cause the oscillatory currents in the bridge to just neutralize each other, or balance out. L_2 is coupled to L_1 so that the detector will oscillate, and L_4 is reversed with respect to direction of winding to L_3 . C_7 is a very small neutralizing type condenser which is set to the same capacity as C_8 . This latter setting is easy to determine in practice. C_6 is simply a "throttle" condenser to control the amount of regeneration or oscillation in the detector circuit, such as is used in practically all modern short-wave receivers. Thus the balanced receiver has one tuning control and one feed-back control, the latter being adjusted only once or twice throughout the whole tuning range of the receiver. Simplicity and ease of tuning have been accomplished in this receiver.

Now for some simple theory as to why the receiver does not radiate when properly balanced. The energy of the incoming signal at any one instant can be represented by the dotted arrows. This energy splits and part of it goes through each coupling condenser, C_1 and C_2 . The tuning circuits associated with L_1 and L_3 , are tuned to the frequency of the desired incoming signal energy and so offer an extremely high impedance to this energy. This means that most of the signal energy is impressed equally across the grid-filament capacity of the detector tube and the small capacitance C_7 . The action thus far is the same as for any receiver. The energy component in the plate circuit of the detector through the tickler coils L_2 and L_4 induce energy in the coils L_1 and L_3 respectively, that in L_1 in a direction as indicated by the single-headed solid arrow, and in L_3 in a direction as shown by the double-headed solid arrow. This is obtained by having the direction of the windings of the coils in reverse directions. The energy induced in L_1 adds to the incoming signal energy of the same frequency and this continuous feed-back causes the detector to oscillate. Unfortunately, part of this feed-back energy, as shown by the single solid arrows, splits at the top of the bridge, part of it going across the grid and the rest through C_1 to the antenna, which can, for our purposes, be represented as an inductance, resistance, and capacitance across the points A and G, as shown in Fig. 1. The energy induced in L_3 , however, is in such a direction as to be opposite to that induced in L_1 in its effect across the points A and G. The net effect in the antenna circuit is zero output from the receiver. Thus we have a one way circuit, the antenna gives energy to the detector but does not take any away.

Since the circuit C_1, L_3, C_7 is tuned to the desired frequency, as is also L_1, C_3, C_8 , these two arms of the bridge offer high impedance to the feed-back energy from the opposite tickler coils respectively, and most of the energy finds its way across the points A and G. The reactance or impedance of the antenna circuit is comparatively low so that the main components of energy are as shown by the arrows. The minute quantities, in comparison with those shown by the arrows, can be automatically eliminated or compensated

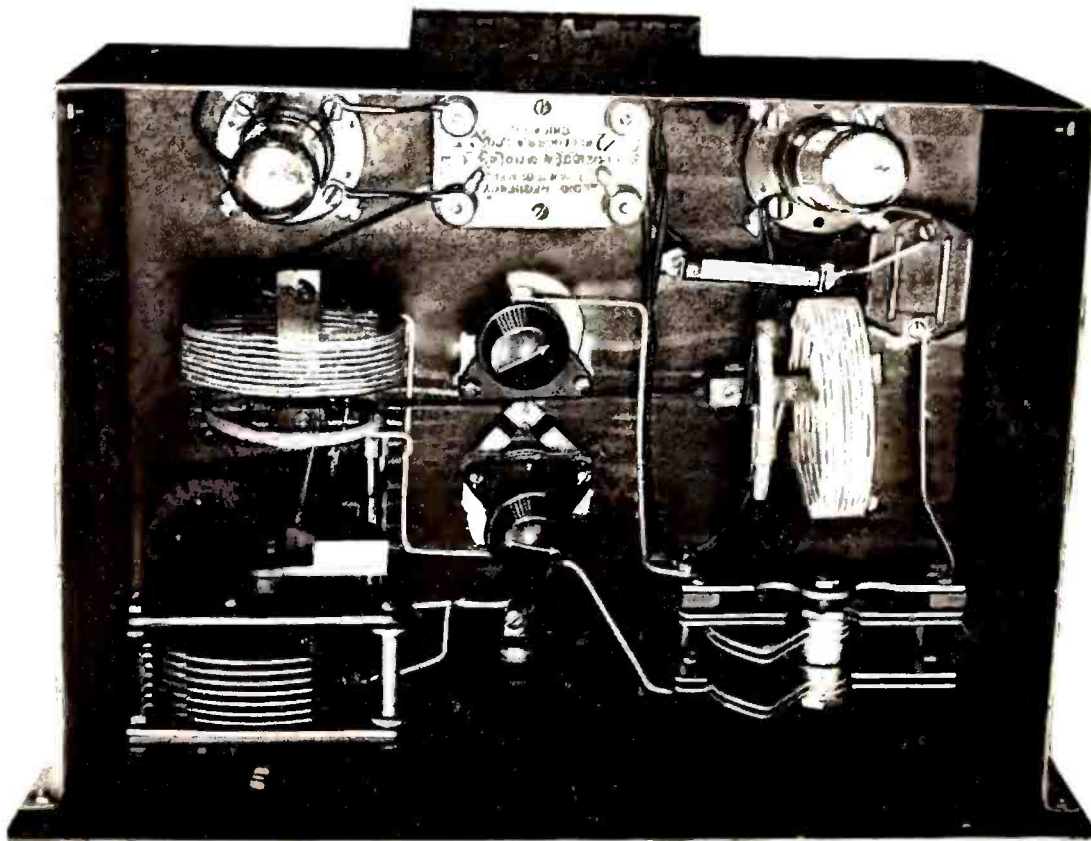

SHOWING THE DISPOSITION OF PARTS WITHIN THE CABINET

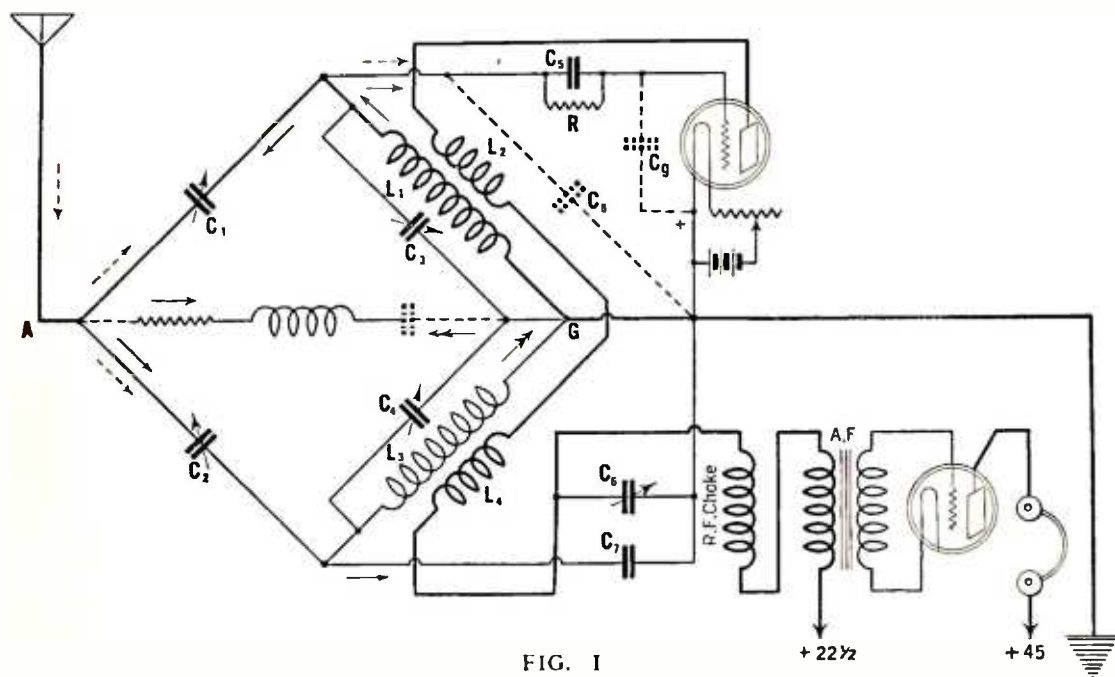

FIG. 1

in adjusting the values of C_1 and C_2 and the relative positions of the tickler coils L_2 and L_4 with respect to their associated coils, L_1 and L_3 .

In order to simplify as much as possible the explanation of this receiver circuit, values of energy were spoken of instead of induced currents and effective voltages. In speaking of induced energy, it was meant that portion of energy which was available at the points of the tuned circuits which would cause a radiation in the antenna system. In tracing through the circuit using currents and voltages, all of the phase differences must be taken into account, which would make it a very complicated explanation of the functioning of this circuit.

CONSTANTS OF THE CIRCUIT

A DIAGRAM which may be somewhat easier to follow in wiring up such a receiver is shown in Fig. 2. The coils L_1 and L_3 should be exactly similar, with preferably spaced winding on a form about $2\frac{1}{2}$ inches in diameter. For covering the 40-meter (7500-kc.) band, 9 turns for use with the 199 type of tubes and 8 turns if 201-A type tubes are used, is about right. In the original receiver, an old 17-plate condenser was rebuilt so that there were two separate condensers in the one unit, each with four plates. This set tunes from about 30 up to 50 meters (about 10,000 to 6000 kc.) when using UX-199 type tubes. The tickler coils, L_2 and L_4 , are similar and are wound with about No. 26 wire on a 2-inch form with 7 turns apiece. Celluloid dissolved in acetone was used in holding these coils in shape and makes a minimum amount of dielectric in the field of the coils, L_1 and L_3 , where the losses should be kept as low as possible. The coils L_1 and L_3 were space wound with No. 18 wire on a $2\frac{1}{2}$ -inch cardboard tube. Four narrow strips of celluloid were laid at equal distances around the cardboard tube and the wire wound over them. Where the wire touches the strips, it was painted with the acetone celluloid solution and allowed to dry, after which the cardboard could be torn out leaving the four strips of cemented celluloid to support the coil turns. The two coil mountings for the four coils were made from strips of hard rubber acting as clamps over the coils, and the whole unit was screwed down to the baseboard of the receiver. This arrangement makes it possible to mount the

The Facts About this Receiver

Name of Receiver	Balanced Short-Wave Receiver (Non-Radiating).
Type of Circuit	The circuit is of the autodyne type in which the detector acts as an oscillator. The local oscillations are prevented from going out on the antenna by a special Wheatstone Bridge arrangement.
Number and Kind of Tubes	Two tubes are used, one as an oscillator and detector, and the other in a stage of audio frequency. Either 199 or 201-A type tubes can be used, a slight change in the number of turns in the tuning coils being required for the different tubes, as explained in the text.
Wavelength Range	30 to 50 meters (9994 to 5996 kc.).

This receiver is the result of further work on the part of Mr. Jones in his efforts to develop a truly non-radiating short-wave receiver which may be used by the average amateur. His first attempt was described in RADIO BROADCAST in September, 1926. The present receiver is more sensitive and radiates far less than the first because of refinements in the bridge circuit.

tickler coils about an inch from the filament ends of the coils L_1 and L_3 , and to vary the coupling to L_1 and L_3 , which is necessary in balancing the receiver. Incidentally, plug-in coils could be used in order to cover the other amateur bands, providing exactly similar coils with their associated ticklers were obtainable with plug-in mountings. The feedback control condenser, C_6 , can be of any type of some value near 0.00025 mfd. maximum, and could as well be controlled by a small knob as a large dial since it has practically no effect at all on the tuning of this receiver. The radio-frequency choke, in series with the primary of the audio-frequency transformer, is in this case a midget honeycomb coil of about 400 or 500 turns of fine wire. Any kind of a small r.f. choke coil can be used here, though one with a very small external field should be used. There

is nothing new or different in the audio amplifier, though a peaked transformer could be used to advantage here, say with a resonant peak somewhere between 600 and 1000 cycles. The coupling condensers, C_1 and C_2 are midget variable condensers of very low capacity, of which there are numerous types on the market. The grid condenser, C_5 , should be about 0.0001 mfd, and the grid leak, R , of about 8 or 10 megohms in value. The detector socket should be well cushioned, a piece of sponge rubber being used in the receiver described.

In balancing the receiver, a separate short-wave receiver should be set up, preferably using separate batteries, but coupled to the same antenna and ground. By listening-in on the regular short-wave receiver, a loud squeal will probably be heard when the two sets are tuned to the same wavelengths. It is a good plan to use about 45 volts on the plate of the detector in the balanced receiver in order to make sure that the oscillations will be quite strong. C_1 and C_2 , together with C_7 , are then varied until the bridge is balanced, which condition will be indicated by there being no interference

in the regular receiver when the two are tuned to the same frequency. If the same relative setting of C_1 and C_2 holds true for the whole tuning range of the receivers, then the receiver is nicely balanced and the tickler coils are coupled to coils L_1 and L_3 correctly, and the small capacity C_7 is correctly adjusted. If the condensers C_1 and C_2 have to be changed, then try readjusting C_7 , and also the tickler coil couplings, until a correct balance is obtained.

In order to improve the receiver shown, the coupling condensers C_1 and C_2 should be shielded from the rest of the set so that there is no capacitive coupling to the antenna on the antenna side of the condensers. In this set, the antenna lead was brought into the set in a bunch of battery leads, which actually shield it to some extent until it reaches the condensers C_1 and C_2 . A good arrangement would be to have the common connection point to the antenna as near as possible to the place where the down lead comes through the shielded box. Another better arrangement would

be to have the twin condenser placed in the center of the front panel and the two circuits placed symmetrically on each side of it instead of in the arrangement as shown in the photograph. The set should of course be completely shielded, in order that no radiation will take place from the coils, etc., of the set itself.

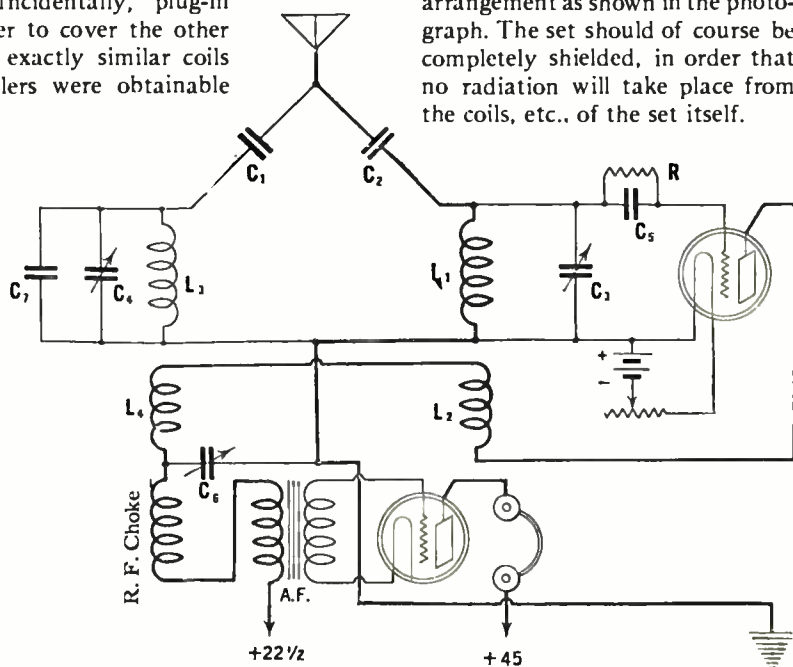

FIG. 2

What About the A Battery?

The Importance of Balance in Trickle Charging—Those Misleading Statements About A Battery "Elimination"—Comparing the Methods of Charging and Their Costs—The Best Rate and When to Charge

By EDGAR H. FELIX

SOCKET Power is a term used to describe devices which enable a receiving set to draw its power directly from the electric light mains. To the uninformed enthusiast, it usually implies a complete elimination of all the elements of the power supply system which require care and attention.

Socket power devices now on the market fall slightly short of accomplishing this desirable result. They do, however, reduce to the very minimum the care and attention required to keep the receiver's power supply at full efficiency. The storage battery and rectifier, which these devices invariably combine in a single unit, do nevertheless require a little intelligent care, and, given that care, are both reliable and convenient.

The most advanced types of socket power equipment comprise a charging device and storage battery so designed that the battery is left on charge at a slow or trickle rate during the entire time the set is not in use. Therefore the storage battery is either discharging through the tubes of the receiver or being charged by the trickle charger. Theoretically, the only attention which must be given such socket power devices is the occasional addition of distilled water to the storage battery and the trickle charger. Even when turning on and off the set, it is not necessary to think about the trickle charger connections because, by the use of an automatic device, the receiver's "on-off" switch disconnects the charger when the switch is turned on, and connects it when in the "off" position. With most devices provision is also made for connecting the power line to a B supply device when the control switch is in the "on" position.

A minimum of attention is indeed attained, *provided* that the trickle charge is of the correct rate to offset the current drawn when the set is used. But, alas, this condition of perfect balance of input to output is not always happily secured. Therefore the filament current requirements of the receiver and the number of hours a day it is used must be determined fairly accurately, and the charging rate by the trickle charger adjusted to meet them. For this reason, A power combinations are equipped with means of adjusting the trickle charge rate to suit the power requirements of different receiving sets.

The importance of balancing charge and discharge becomes apparent when we consider the effects of undercharge and overcharge upon the life and condition of the storage battery. If the trickle charge rate is too low, the battery voltage will fall gradually until the set at last

fails to function because of a discharged A battery. In this case, unless the trickle charger has a high charging adjustment which permits bringing back the battery from its discharged state to full charge quickly, it is difficult to restore it to good working order without the assistance of a high-rate charger. When a user experiences a run-down A battery, he naturally increases the trickle charging rate to the maximum, which should bring the battery back to full efficiency in several days. But often, he considers such an experience as evidence that the charging rate should permanently be kept at maximum. For a long time, perhaps even two or three months, this rate gives satisfaction because the battery is always kept fully charged, but, sooner or later, the battery breaks down completely from prolonged and continued overcharging. Active material starts to fall out of the plates and, also, the specific gravity of the electrolyte may rise to a high value and the distilled water of the solution requires renewal every few days. Usually the manufacturer is condemned for these misfortunes, while the cause is simply incorrect setting of the trickle charging rate.

Different socket power devices use different combinations of charging rate. Philco, for example, has three adjustments, low, medium, and high, giving 0.2, 0.33, and 0.6-ampere charging rates respectively. Willard uses a low and a high adjustment, giving 0.5 and 2.0 amperes, while Gould offers no less than five adjustments, 0.2 to 0.25 ampere, 0.275 to 0.320 ampere, 0.350 to 0.425 ampere, 0.450 to 0.750 ampere, and 0.9 to 1.5 amperes, according to line voltage.

With charging rates as high as two amperes available, the danger of grave overcharge, resulting in quick destruction of the battery, is constantly present. On the other hand, a few hours a week with a high charging rate, and a low trickle charge for the balance of the time, will keep the battery in the best of condition.

There are always occasions when a set is used a great deal for a few days for special reasons, and in this case a higher charging rate is temporarily necessary to bring the battery back to full charge. The table on page 27 shows the charging adjustments recommended by Philco. This table gives the average number of hours a day a set may be used at various current drains and charging rates. For example, with a five-tube set used 3.02 hours a day, each tube drawing a quarter of an ampere, the trickle charger at the 0.2 ampere adjustment will keep the battery up to full charge. If the set is used but two hours a day, the trickle charger should be shut off by removing the attachment plug occasionally so that constant overcharging is avoided.

On the other hand, such a five-tube receiver may be used for twelve hours within two days because of some special broadcasting event, and this would draw a total of fifteen ampere hours from the battery. For example, the set may be in use from eight o'clock until one a. m. on one evening and from six o'clock to one a. m. on the next, drawing a total of fifteen ampere hours from the storage battery. Between these two periods of listening, and between the second period and a third period which we shall suppose commences at eight o'clock on the third evening, the battery is recharged for thirty-six hours at the low rate, which gives it back 7.2 ampere hours. Now, if the current drain, after this experience of twelve hours' use in two days, is continued at its normal average for about three hours daily, and the normal charging rate of 0.2 ampere is maintained, the battery may never be restored to full charge.

Understanding these conditions, it is not difficult to understand the correct charging rate. Estimate the average needs of your set in ampere drain and hours of use and adjust the trickle charging rate recommended by the manufacturer for that load. If you depart from this average use by extended use on special occasions, use a higher charging rate for a few days to counter-balance it. On the other hand, if the receiver is subject to long periods of disuse, disconnect the attachment plug for a few days when you estimate the battery to be in a fully charged condition. These are operations of the utmost simplicity and, by observing

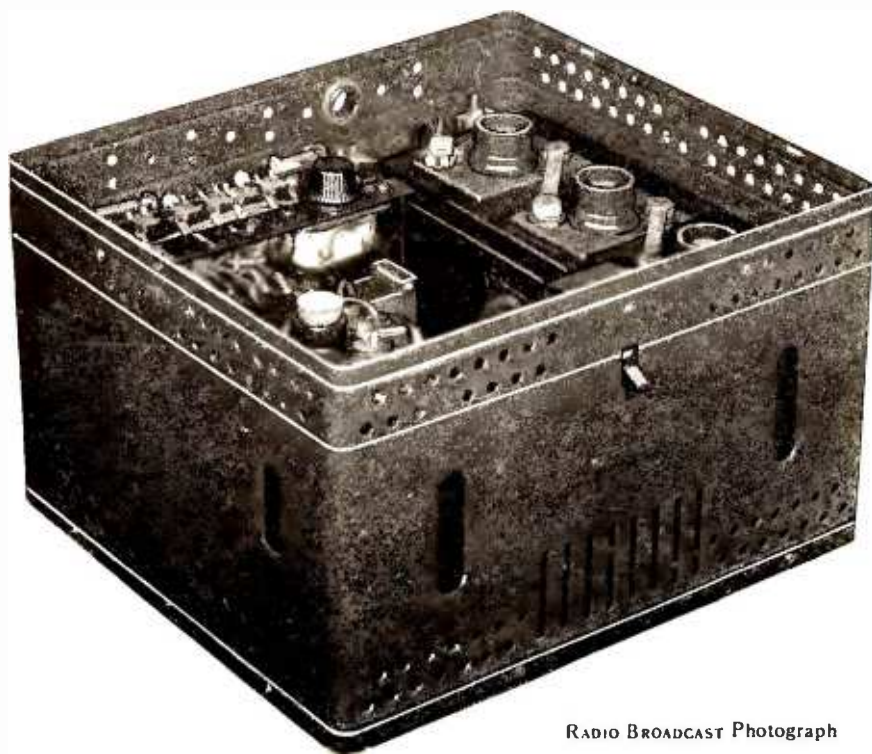

RADIO BROADCAST Photograph

A THREE-IN-ONE SOCKET POWER DEVICE

Combining trickle charger, storage battery, and B power supply in one unit. Although there are many manufacturers combining the first two in one unit, there are comparatively few who manufacture such a device supplying B current also

them, you get the true convenience of socket power.

The only other attention required to keep a socket power device in working order is to keep it constantly filled with fresh distilled water. The Gould "Unipower" has an ingenious method of reminding you of this water matter because the rectifier cell is so designed that the rectifier cuts off just before the storage battery needs renewal of water. Hence the battery will go dead before its plates have been unduly exposed because of lack of water. Philco supplies a convenient hydrometer with certain of its larger storage batteries, fastened in the top of the cell case. If the water is at the proper level, squeezing the hydrometer bulb draws electrolyte into the charge indicator. If it fails to do so, you are plainly warned that the water must be renewed. Philco and others also use built-in charge indicators which permit one to see the electrolyte level through the glass walls of the cell, simple markings indicating the danger point.

MISLEADING STATEMENTS

WE HAVE observed the advertising and literature of several concerns purporting to describe A-battery eliminators or insinuating that their devices eliminate A-battery troubles, storage battery attention, etc. A number of these devices which we have examined, are simply storage batteries with trickle chargers. To imply "elimination of storage battery troubles" with such devices is plain deception. If manufacturers are not above using such deception in their advertising, dealers can hardly be blamed for extending this misrepresentation to the consumer. Readers are therefore warned to examine so-called A-battery eliminators carefully before purchase, lest they prove to be only the conventional trickle charger-storage battery combination. They then require the simple attentions herein recommended and will fail in service if they are not given it.

The condition of a storage battery, whether used in connection with a trickle charging device or otherwise, is not difficult to check so long as it receives fairly normal treatment. Voltmeter readings, however, should not be relied upon unless a very accurate, high-grade instrument is used.

A hydrometer is very useful for the purpose, because it is inexpensive and somewhat more accurate in its indications than a voltmeter. However, it too is subject to certain slight discrepancies which, when understood, are not difficult to account for.

When a battery is fully charged, the specific gravity is at its maximum. Constant overcharge produces boiling, reducing the water in the solution and accordingly increasing the specific gravity. Extended and continued overcharging (such as that resulting from an excessive trickle charging rate) tends to force the sulphuric acid to the top of the cell so that we sometimes get a high specific gravity reading although the battery goes mysteriously dead after a few minutes of use.

Another misleading state is manifest when an unusually strong sulphuric acid solution is used. This subterfuge is sometimes employed to make a storage battery appear better than it really is. In automobile service, where extremely heavy current is drawn for a few seconds, it is of advantage to use a strong solution because an electric starter sometimes draws as much or more

than ninety amperes from the battery but, with a radio battery, no such heavy loads are drawn. The only advantage gained by the use of a strong solution is a little higher terminal voltage and better specific gravity reading; on the other hand, it causes more rapid deterioration of the plates. The specific gravity reading for a radio storage battery at full charge should be between 1225 and 1300, depending upon the recommendations of the maker. The majority of radio

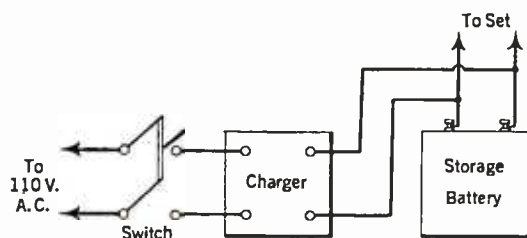

THE CHARGER ARRANGEMENT

The double-pole single-throw switch is for disconnecting the a. c. power source when the set is in use. The charger is left connected to the storage battery while the set is operating, but unless you are sure that the grounded side of the power line tallies in sign with that of the A battery, the latter should be disconnected from the set during charging hours, unless otherwise specified by the manufacturer of the charger

batteries use an electrolyte showing a reading between 1265 and 1285 at full charge. Recharging should be begun when the specific gravity falls to 1200. Complete discharge is between 1100 and 1150, according to the strength of the electrolyte.

The actual value of a storage battery to a user is determined by:

1. Its voltage output.
2. Its capacity, as determined by its service requirements.
3. Its life.

The voltage is simply a matter of having the correct number of cells and, for radio purposes, the six-volt standard is established by the requirements of storage battery tubes. Four-volt storage batteries are sometimes used for large dry cell sets employing the UX-199 type tubes.

DISCHARGE REQUIREMENTS

THE rated capacity of a storage battery is usually fixed at the maximum amperage which the battery will deliver in a complete discharge of 100 hours. Thus, a one-hundred ampere-hour battery will deliver twelve amperes for a little over eight hours. At higher discharge rates, it

FILAMENT CURRENT, AMPERES	RATE AND HOURS SERVICE		
	0.2 AMP.	0.33 AMP.	0.6 AMP.
0.25	10.0	13.1	16.4
0.50	6.35	9.00	12.4
0.75	4.65	6.86	10.0
1.00	3.66	5.54	8.40
1.25	3.02	4.64	7.24
1.50	2.57	4.00	6.35
1.75	2.24	3.50	5.56
2.00	2.00	3.13	5.10

A RATE-OF-CHARGE TABLE

Which shows at a glance how many hours a day you may use your set and keep the storage battery fully charged by leaving the trickle charger on for the other hours of the day. For example, suppose you had a five-tube receiver, using four 201-A type tubes and a UX-171 type power output tube. This combination would draw 1.5 ampere hours from the battery per hour. The set could then be used for four hours daily providing the trickle charger was left on for the remaining twenty hours at an 0.33-amp. charging rate

gives a lower output in ampere hours, while at a lower discharge rate, somewhat higher capacity.

The effect of drawing an exceedingly high amperage from a storage battery is to concentrate the chemical action of discharge upon the surface of the plates. One of the by-products of discharge is the gradual formation of a high resistance coating of lead sulphate on the plates, and this increases the internal resistance, thus causing battery voltage to fall. A slow discharge rate permits the withdrawal of energy from the very heart of the plate itself and, in so doing, causes the formation of lead sulphate to some depth in the plates. Consequently, the small drains and low charging rates of radio service are harder on storage batteries than the heavy periodical drains of the automobile storage battery.

For this reason, a much heavier and better built form of plate must be used to withstand the ravages of radio service. This is particularly the case in trickle chargers, which are constantly subjected to chemical action by charging or discharging electric potentials. The service life of a storage battery is largely determined by the thickness and quality of the plates. For example, a plate with active material a quarter of an inch thick is good for about 600 to 800 cycles of complete charge and discharge, while one of half that thickness is good for only about 300 cycles of complete charge and discharge. Hence thickness of plates is one of the hidden qualities which determine the value of a storage battery as an investment. The value of purchasing a battery made by a manufacturer of established reputation is apparent when we realize that the true value of a storage battery is completely concealed by its case.

Although a storage battery should not be subjected to continued and prolonged overcharge, it should, on the other hand, be given at least two to four hours overcharge about once a month. This tends to reduce the deleterious effect of sulphation and maintains the battery at its highest efficiency. By overcharging is meant continuation of the charging process after the battery has reached the full charge point. During this part of the charging process, gassing takes place freely and, for this reason, the vents of the battery should be removed.

Only distilled water should be used in replacing that lost by evaporation. It should be added before charging the battery and not afterward in order that it may be thoroughly mixed with the electrolyte during charging. The use of other than distilled water introduces traces of metals and other impurities into the cell, resulting in parasitical electro-chemical actions within the cell, which reduce its output. Rain water, collected in clean containers by direct precipitation, without first passing down roofs and through leader pipes, may be used, as well as clean snow, gathered in clean bottles immediately after a snowfall, if there is no dust or smoke in the air. Distilled water, however, is quite inexpensive and there is little reason for trying to save on this item, thus possibly risking the serviceability of a storage battery worth fifteen or twenty dollars.

The excessive evaporation of distilled water to below the level of the tops of the plates means that a part of the plates is not used in charge and discharge, reducing the capacity of the battery, also that the electrolyte is more highly concentrated, both of these being undesirable results.

The cases of storage batteries are now so well designed that they are usually quite sanitary. Hydrometers are equipped with non-drip points so that keeping the battery clean is reduced to a small labor. Another convenient form of hydrometer, as stated previously is designed as part of the vent caps, to be screwed permanently into the top of the cell cases. This type eliminates the risk of dripping electrolyte, which damages carpets and furniture. If acid sometimes gets on the outside of the battery, it can be taken up with blotting paper or with a cloth which has first been soaked in ammonia. Local chemical action forms a coating on the terminals of the battery as a result of moisture or spray from overcharging. This should be carefully removed by means of soda water applied with an old tooth-brush, followed by final cleaning with a file or scraper. This precaution is apt to be slighted and is often the cause of receiving set noises. After cleaning the terminals and connecting clips, cover them with vaseline. It will keep them uncorroded for a period of several months.

When a trickle charger or A-battery socket power unit is not employed, other types of chargers are available. Those of the vibrator type are the least expensive. They have the disadvantage of causing noise and, if the vibrator contacts stick, feeding alternating current into the storage battery. New contacts are easily installed at low cost and a fine file can be used to keep the contacts smooth and fairly silent.

Electrolytic chargers of various kinds can be purchased separately or in combination with small storage batteries, forming a socket power unit. These require the addition of distilled water about as frequently as the storage battery itself needs it and, generally after a year or two of use, renewal of the active electrode. Occasionally new acid is needed for the rectifier and that is best renewed at a battery service station, usually at the cost of a dollar or two.

Bulb rectifiers are generally of the two-ampere or five-ampere type. A bulb is usually good for two thousand or three thousand hours of charging. For example, a set which requires a twenty-five ampere-hour storage battery supply a week can be recharged and maintained by five hours charging a week from a five-ampere charger. This is the average A power requirement of a four-tube storage battery set used about three hours a day. A charger bulb used in this modest service would last for many years. In trickle charger service, however, the bulb would be in use about 140 hours a week instead of but five and would therefore last only five or six months. The bulb depreciates as rapidly when furnishing half an ampere as when furnishing two amperes.

Some trickle charger outfits are fitted with bulb chargers. Only when the current drain from a storage battery is so large, by the use of a multi-tube set for many hours a day, is a trickle charger of such large capacity necessary. Otherwise the overcharge danger, to which we have already referred at length, occurs, and the life of the charger bulb is reduced to a matter of months, unless the trickle charger is disconnected from the line a good part of the time. For example, a half-ampere rate, supplied forty hours a week, instead of the entire time the set is not in use, may tenfold the life of the rectifier tube, cut the electric power required to one tenth, and greatly increase the life of the storage battery, by avoiding continued overcharging.

Since the crux of the whole matter of storage battery life and economy is a matter of correct charging rate so as to assure ample current in the battery when you need it but not at the cost of continued and damaging overcharging, it may be of advantage to suggest a simple charging policy which meets the requirements of the average individual.

With bulb type chargers (whether combined in trickle charger units or not) it is preferable to use the two-ampere rate on the required number of overnight charges per week necessary to keep the storage battery in condition. Experience will determine whether one night a week or two nights a week is sufficient to keep the battery in good condition, showing full charge at the end of the charging period and still giving reasonable service voltage before charging is begun again. Five-ampere chargers bring the battery back into condition quickly, but they offer a rate which is generally a little high for radio receiving requirements. A high charging rate means more intensive chemical action with consequently intensified deterioration of the plates.

With chemical types, low charging rates are generally available. Perhaps the easiest policy to pursue is to use a low charging rate during the week, which seems to keep the set going satisfactorily under ordinary conditions, without permitting the storage battery to reach a nearly discharged condition at any time. It may be below full charge a good part of the time without danger so long as it is not showing a specific gravity below 1.150 at any time. Then, over the week-end, give it a high charging rate, if that is necessary to bring it to the full charge condition. If the set is used for prolonged periods, one or two nights during the week, so that the balanced condition is upset, restore the battery to its normal condition by a few hours at a high charging rate.

There may be occasions when a low trickle charge rate keeps the battery constantly at full charge and the renewal of distilled water is found necessary more frequently than once a month. This indicates continued overcharging and should be avoided by disconnecting the trickle charger from the set one or two days a week. When some such formula, which gives the balanced condition, is established, storage battery maintenance becomes a simple and easy matter.

CONCLUSION ABOUT CHARGING

IN THOSE few areas served by direct current, rectifiers are not suited to storage battery charging. The only thing required is some form of resistance so as to reduce the current supplied to the battery during charge to the value which it requires for the purpose. A convenient form of resistance is an electric light bulb connected in series with the battery, of a wattage determined by the battery's charging requirements. A fifty-watt lamp, connected with a six-volt storage bat-

tery, supplies about half an ampere; four such lamps in parallel will deliver two amperes. The circuit diagram on this page shows the correct circuit connections.

Two precautions should invariably be observed when charging storage batteries. First, be certain that the positive or plus, charger lead is connected with the red, plus, or positive A-battery terminal and that the negative charger lead is connected with the minus A-battery terminal. Second, disconnect the radio set from the A battery terminals, unless you are absolutely certain that the power line is not short-circuited through the charger.

To determine the polarity of the power line leads when charging through a bank of lamps plunge the terminals to be connected with the battery into a glass of salt water solution. Bubbles will rise from the negative terminal. Rectifiers of the electrolytic and bulb type have plain markings, usually employing a red wire for the positive lead.

Many misleading statements have been made as to the cost of battery maintenance. Service stations charge from fifty cents to one dollar for charging a radio battery and, if this service is required twice a month, the cost comes to one or two dollars a month, plus inconvenience and "time out" because the set is not in service.

Chargers of various types are generally advertised as drawing negligible current from the line but this is not always true. The most efficient way to charge a battery is with a standard charger capable of supplying several amperes—say two. Such chargers draw 25 or 30 watts from the line so that, if used five hours a week, only about one seventh of a kilowatt, costing from two to three cents depending upon the locality, will be used. Trickle chargers draw from 5 to 20 watts from the line, the average being about 10 watts. Assuming you use a set three hours a day, this means about 630 hours of non-use a month which, at 10 watts, means 6.3 kilowatt hours. The average rate is ten cents a kilowatt hour so that the upkeep cost for electric power is about sixty three cents a month. The chemical type of charger is somewhat more efficient than the bulb type when they are used for trickle charging and, for this reason, from the standpoint of economy, the electrolytic type is preferable although this advantage is offset by the fact that the chemical type requires more care in its upkeep than does the bulb type.

Since it is advantageous to disconnect the trickle charger if it subjects the battery to over charge, we find in power economy an added argument for disconnecting the trickle charger two or three days a week. In this way current cost, with practically any type of charger, may be reduced to less than a dollar a month.

We therefore find that A power satisfaction, with due consideration to convenience, economy, and reliability, is most readily attained by observing the following:

1. Use a charging system, whether trickle or high-rate, which balances the load from the battery.
2. Keep the electrolyte level of rectifier and storage batteries correct by the addition of distilled water.

The first rule may require occasional disconnection of the trickle charger or the use of a higher charging rate for limited periods. The reward for obeying these most simple precautions is unailing and reliable A battery service at low cost.

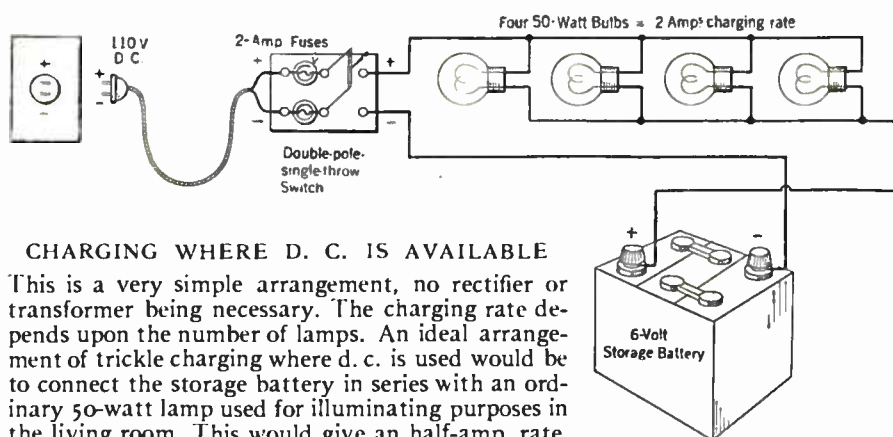

CHARGING WHERE D. C. IS AVAILABLE

This is a very simple arrangement, no rectifier or transformer being necessary. The charging rate depends upon the number of lamps. An ideal arrangement of trickle charging where d. c. is used would be to connect the storage battery in series with an ordinary 50-watt lamp used for illuminating purposes in the living room. This would give an half-amp. rate.

THE LISTENERS' POINT OF VIEW



Conducted by John Wallace



How Long Will Radio Broadcasting Prosper?

DOPING out what is going to happen in the future is always a pleasurable, if hardly ever a profitable, pastime. Most dopesters of radio's future are extravagant in their prophecies of ever-widening influence and ever-increasing prosperity. We are inclined to agree with them, providing they do not attempt to push their claims too far into the future. For it is our conjecture that radio will arrive at its full maturity in a very few years. From then on its course will be no more sensational than is that of the talking machine at the present time. And in a decade or so will come some new contraption that will relegate radio to as exciting and varied career as that of a telephone operator.

But this inevitable cycle could, conceivably, be nipped in the bud (astounding mixed metaphor) by the failure of radio to keep up with the exactions of a public which has already become inured to its novelty. Concerning this possibility we have an interesting letter from a reader, J. R. Coolidge 3rd, of Brookline, Massachusetts, which presents a good analysis of the factors which will determine radio's longevity. Mr. Coolidge says in part:

"Answering your questionnaire has prompted me to go further into the fundamental questions which affect the future of radio in this country, questions which radio enthusiasts discuss eagerly whenever they meet and for some strange reason rarely put on paper.

"Without having any statistics at my disposal I will assume that there is one radio receiver in use for 50 per cent. of the families in America, and that B. C. L.'s may be divided into three important classes:

"1. Average normal healthy citizens who buy standard sets in good looking cabinets as an investment in entertainment and as a piece of furniture for the living room and because their neighbors have one. This class spends from \$50.00 to \$300.00 on an outfit once in about five years and then about \$25.00 per year in upkeep.

"For them, this investment cannot be worth while in the long run if most of the 'entertainment' is dance music, jazz, cheap popular songs, etc., because the same amount of money would permit them to hear the original performances at frequent intervals and to go to the dance halls, etc., where this class of music is current. If this is to be the prevailing type of program, the majority will cease to use their receivers after the novelty wears off. To hold the interest of this large class permanently it will be necessary to provide music of very high quality indeed, not necessarily heavy classics only but any good music played by well trained orchestras, organ recitals by the most skilled players, good instrumental solos, etc., in the field of music. In other fields, such as politics, education, religion, athletics, and radio plays, the same standards must be maintained if broadcasting is to be permanent. Give the B. C. L. something at home which would be expensive or impossible to obtain outside, and his receiver will be in use every night.

"2. Invalids, shut-ins, convalescents, aged people, those who are hard of hearing, and those who have poor sight. This class is not nearly

so large numerically as the first but it is very important because nearly every family has at least one member. To this class, the radio is more than mere entertainment; it is their constant companion. Instead of mere 'news flashes' a good reader could read them in detail extracts from the morning papers every morning, including the best editorial comment. The same could be pursued with regard to magazines and popular novels (a chapter a day). For this class a certain amount of popular music, etc., could be worked in at appropriate intervals before the healthy members of the family returned from their daily occupations. This class does not buy radio receivers, but uses the family receiver hard and constantly. Often it is because of them that the receiver is purchased.

"3. The smallest class, the enthusiasts and experimenters, who buy radio parts and build and rebuild their own receivers, constantly striving to improve the quality, the selectivity and sensitivity of reception, always spending more than they can afford, whether it be in tens, hundreds, or even thousands of dollars, on their equipment. Most of the readers of RADIO BROADCAST must belong to this group, because they alone, among B. C. L.'s, are interested in technical questions and details of construction.

"This group has special requirements—it wants high grade programs just as much as the first group, but in addition it must have DX because DX is a definite measure of comparison between receiving sets in the matter of sensitivity."

The writer's classification of radio listeners seems to us an accurate one, as does also his outline of their respective demands. The first group, he says, must be guaranteed first class entertainment or they will gradually lose interest and finally abandon radio altogether. There need be no grave fears on this score however, for this fact is realized by a sufficient number of radio station operators. Of course it is not realized by all. But that is their hard luck. The



AN INFANT PRODIGY AT WRVA

Conrad Rianhard, aged nine years, who is said to have mastered, to an incredible degree, many difficult piano compositions

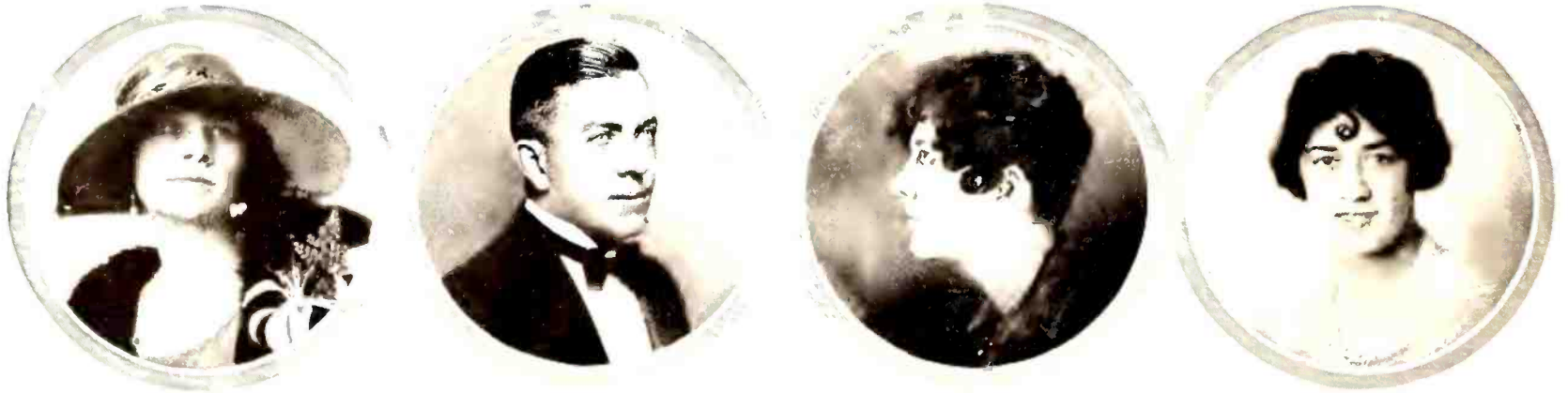

NO STRANGERS TO THE MICROPHONE

The first is Eva Gruninger Atkinson, contralto, who sings from KPO; next is Keith McLeod, studio manager and pianist at WJZ; the third is Miss Honarine La Pee, a "syncopating pianist" at KMOX. Miss La Pee recently won a contest as the most popular artist on the staff of this St. Louis station. The fourth photograph shows Miss Josephine Holub, violinist on the "Pilgrim" program, heard from KGO on Tuesday nights

listeners, instead of abandoning their receiving sets, will abandon the inferior stations, whereupon the inferior stations will go out of business.

The service which radio can perform for Mr. Coolidge's second group is undeniable. However, it is a *service*. That is, it is a department which can bring the broadcaster no demonstrable financial return. Evidently, in this day of cut throat operation, no station manager can afford to devote much time and thought to a group which is numerically small. But when time and the operation of the 1927 Radio Law has winnowed the existing number of stations down to a comparative few, these stations will find it not only possible, but advisable, to provide features for minority groups.

Why a Good Program Was Good

THE inaugural program of the National Broadcasting Company, which took place last winter, has come in for quite a lot of praise. Perhaps the most authoritative testimonial to it was that of Samuel Chotzinoff, music critic of the *New York World* in his column: "Concert Pitch." Commenting on the arrangement of the program, Mr. Chotzinoff said.

If Mr. Aylesworth constructed this masterpiece of program making he proves himself a better psychologist than all the orchestra conductors we have ever listened to. Mr. Aylesworth knows that the untutored radio ear cannot be much different from the sophisticated concert ear. Four Beethoven sonatas on the same program are as boring to the trained musician as they are to the public at large, even more

boring, in fact, because the musician knows what he is in for.

Mr. Aylesworth might have followed the ethereal "Lohengrin" prelude with the equally ethereal prelude to "Parsifal" and by doing so alienate the radio fans from Wagner forever. Instead,



JAMES PEARSON

The "Newsboy" at KFNE, Shenandoah, Iowa. Mr. Pearson gives a digest of the news at 7:45 P. M. "The Newsboy" is also heard in a health talk at 7:50 A. M. On Sundays, Mr. Pearson gives religious talks

he isolates the "Lohengrin" piece by following its last pianissimo with the lustful, mundane chorus from "Tannhauser." Who but Mr. Aylesworth, ever thought of presenting only the first movement of Schumann's concerto? This movement contains the best of Schumann's inspiration—the other two are anti-climax. During the intermezzo of this concerto, people have a tendency to scan the ads. in the program. Mr. Aylesworth must have noticed this and decided not to take any chances. Even the first movement demands the listeners' closest attention, so Mr. Aylesworth gives his invisible audience a chance to relax by bringing on Mary Garden at once. Mary chooses her own songs, but her personality is intriguing, whether she decides to sing Bach or Irving Berlin. Bear in mind that it is Mr. Aylesworth's purpose to keep his twenty millions from straying out of earshot of the loud speaker.

Those who feel that the Chorale from "Die Meistersinger" is a little too steep will stay to hear the "Lost Chord," which follows it. Will Rogers follows the "Lost Chord," etc.

Compare this amazing program with, let us say, that of the Cleveland Orchestra, which paid us a visit last week. The Clevelanders played a Mozart symphony, the Stravinsky "Fire Bird," and three new American compositions. With the exception of the symphony, for which Mr. Aylesworth can match the Schumann concerto and the Wagner numbers, the highbrow orchestra gave us nothing near as good as any number on the radio program.

As I see it, it isn't the radio that needs encouragement. Mr. Aylesworth should be consoled. The so-called legitimate musical events get the great volume of critical comment because they need it. The radio seems to be getting along beautifully without it.



AT STATION CKNC, TORONTO

Frank Blachford, violinist of the Toronto Conservatory of Music Instrumental Trio; R. H. Combs, general manager of CKNC, which is owned by the Canadian National Carbon Company; Arthur Blight, baritone, frequently heard from this Toronto station

Thumb Nail Reviews

WEBH (and others)—The last act of "Il Trovatore" by the Chicago Civic Opera Company from the Auditorium stage. This was the second trial at broadcasting the Chicago Opera and it proved an incredible improvement on the first job. The voices, which in the first attempt were blurred and echo-y, came out clear and undistorted. The orchestra, as before, was well picked up. In fact the whole broadcast made us reconsider our statement that we had little faith in theater broadcasts. It was in every way a success, and to our taste vastly more pleasant than watching the same opera. An unforeseen delay brought this act on almost an hour late. The attempt of the broadcasters to fill in this wait without specially prepared "filler" was indeed a sorry one.

WMAQ—The Woman's Symphony Orchestra of Chicago playing the Caesar Franck symphony, which is heard all too infrequently by radio. The first movement of this symphony, full as it is of luscious tunes, could be made quite as popular as the hackneyed William Tell overture if radio orchestras would give it sufficient airings. And as real music goes, it would constitute a large improvement on the Tell piece.

WBAP—Jazz, pre-war jazz of a vintage we thought entirely exhausted. But evidently it is making a last stand in the hinterlands. Jiggly jazz with stops, panting jazz with a hurry-up tempo, noisy jazz with neither rhyme nor reason.

WHT—Al and Pat, the ultra-lowbrow Hello-folkers-ers of a super-lowbrow station, supplying us with one of the very few stomach laughs we have ever got out of radio. With Al at the organ, Pat commenced reeling off the weather reports in delightful burlesque of our old friend the Pianologue. While Pat improvised a melodramatic and quavering accompaniment on the organ, Al recited, in the manner of one depicting little 'Liza's flight across the ice: "For Iowa increasing cloudiness and rising temperature Saturday (sob). Rain Saturday night (tremolo). Sunday cloudy to p-p-p-partly c-c-c-cloudy (blubber), preceded by rain or snow (tears and a complete breakdown)."

WLS—Haymaker's Minstrels. Oh how sad! Minstrel Shows just naturally don't get over by radio. Even the best of minstrel jokes need the reinforcement of a clowning End Man and the cooperation of a lenient For-the-Benefit-of-Charity audience. As for the worst of minstrel jokes—well those were the type essayed by the Haymakers. For instance: A long discussion between two End Men as to the definition of a new moon, capped after many minutes of futile introduction with the side splitting climax "If a man by the name of Moon had a son he'd be a new Moon!"

KOA—Monologue by a Mrs. (or was it Miss?) Harrison. First rate, and in excellent style for radio delivery. Mrs. (Miss?) Harrison is acquainted with one of the principal secrets of success in humorous broadcasting, to wit—that of not pausing after each wise crack for a laugh. Nobody laughs out loud at a radio joke anyway so such pauses are simply flat. This monologist rushed through with her lines at top speed and without underscoring her jokes by a changed inflection of the voice. The ludicrous laugh which punctuated her remarks lost nothing of its mirth in the broadcasting. The sketch was original and had to do with a club woman's busy day.

WJZ and Blue Network—A new radio team, Vernon Dahlhart, Carson Robinson, and Maruy Kellner, specializing in light popular selections,

comedy numbers, and songs of the South. Dahlhart, the singer and spokesman, has a non-obnoxious Southern accent, striking a happy mean between the orthodox "number" and the Southern "numbah." The accompanying instruments are a guitar and a violin. Rather good.

WHT—Al Barnes and Pat Carney again; this time in the "Your Hour," presenting "A Trip Through the Dials." Highly comical in a boisterous, infectious way. Why, we ask ourselves, have we been missing these perfectly elegant low-brows all these years? To those of you who become wearied at the lofty pomposity of Doctor Damrosch, we heartily recommend the artfully artless Al Barnes as an antidote.

WJZ and associates—The First National To-Be-Weds issuing propaganda for various picture shows in the guise of a controversy on the merits of a movie just witnessed. Terrible!

WEAF, WJZ, WEEL, WBZ, WTIC, WJAR, WTAG, WCSH, WGR, WGY, WLIT, WRC, WCAE, KDKA, WTAM, WSAI, WLW, WWJ, WGN, WMAQ, KYW, KSD, WOC, WCCO, WDAF, WFAA, WSM, WMC, WSB, KFKX, KVOO, KOA, KSL, KPO, KGO, KFI, KGW, KOMO, KFOA, KHQ, WJAX, WHAS—A speech by one Calvin Coolidge on the occasion of Washington's Birth-



ON THE AIR AT WBBM, CHICAGO

Howard Osburn's International Radio Orchestra. Left to right: C. Mason, P. Beckler, H. Osburn (leader), G. Moorehead, and N. Sherr

day. But of course you heard it, so write your own review. This is simply for purposes of record.

WAU—Celebrating the installation of a new 5000-watt transmitter by reading a lot of telegrams and sending the best regards of the chief engineer to some personal friend of his in Florida.

WAAT—Nut Club at 2 A. M. Oh well, it was our own fault for staying up that late.

KOIL—A radio play "The Scoop." Good in that it was easy to follow and had a quick moving plot. But the lines were amateurishly written and read in a none too convincing manner.

WFAK—(or WFAD or WFAJ or WPCX!?)—Clearwater, Florida. A garrulous announcer who took up at least as much time between numbers as the numbers themselves, and in spite of all his wordiness never succeeded in pronouncing his call letters so they could be deciphered by any one other than a magician. In striking contrast to—

KFI—whose announcers, realizing, no doubt, that they represent the most sought after DX station, call their letters with a pause between each one making the signal intelligible through even the worst static disturbances.

KMA—Henry Powell doing some excellent old time fiddling. Followed by a trio playing conventional, uninspired jazz.

Microphone Miscellany

WE ARE eternally deluged with printed matter telling us how this feature drew three thousand telegrams of commendation and how that artist receives 'em at the rate of three a minute while his concert is in progress. While we frequently scoff, there must be some truth in the matter. If so, it is only reasonable to surmise that the advent of radio has brought the telegraph companies an enormous increase in revenue. Then if this be so, we suggest, with no very valid argument to back up the suggestion, that the telegraph companies return some of this gold to the people by sponsoring a weekly program. If the reports of large telegraphic returns made by radio press agents are veritable, which the telegraph companies will probably now deny, we can see no reason why they shouldn't spend several grand a week dishing out

a first rate program. And if their programs were good enough they might receive enough of telegrams to pay the entire cost of said programs—which is something like the worm devouring himself.

THE KFI-KPO-KGO network has been broadcasting a series of concerts by the Los Angeles Philharmonic Orchestra. The final concert will be on April 23 from 9:10 to 10:45 P. M. Walter Henry Rothwell is conductor.

Communications

SIR:

The National broadcasts form 95 per cent. of what's worth while on the air to-day and they are making, or rather *saving*, radio, but unless one goes up and down the dials on the hour and the half-hour he's liable to miss much that is really good and worth while, for nowhere are these programs all listed—the chaff winnowed

from the wheat. Many metropolitan newspapers own or are affiliated with some one broadcasting station, and labor under the short-sighted policy that they should make no mention in their daily radio programs of any big event that is going out through stations other than their own. On New Year's Day, for instance, the Chicago *Tribune* featured the fact that it would put on the air that afternoon, through its station, WGN, a telegraphic report of the Leland Stanford—Alabama football game in Pasadena, "with the WGN Quartet singing college songs and furnishing the local color." Thousands of fans in this part of the country listened to Quin Ryan's "kiss-proof-lip-stick" voice broadcast this big game from the ticker, not knowing that KYW and the WJZ Chain was putting it on the air direct from the Rose Bowl!

And one other thing in this connection: If I were a national advertiser, spending from \$1000 to \$10,000 a week in creating good-will by giving the radio public the splendid programs that such advertisers are giving, I'd see to it that I had real coöperation from certain participating stations and the newspapers which own them. Station WGN never misses an opportunity of cutting off the New York announcer; and the Chicago *Tribune* does all it can to create the impression that it, The World's Greatest, at great expense, out of pure love, is furnishing this wonderful program to its Dear Readers. It hides

altogether, or keeps well hidden in the background, even the name of the advertiser.

These great, national broadcasts can't continue unless they bring their sponsors at least a fair return, and they are not going to bring such return unless they are tied up with a certain amount of definite publicity for the advertiser in question, both in the news and over the air.

R. H. J.

MILWAUKEE, Wisconsin.

SIR:

Your fourth question on the enclosed questionnaire has been answered in a general manner because I think American people tend to judge the quality of their cigars by the price. ("What are the six best broadcasts you have heard?" was the fourth question in the recent RADIO BROADCAST questionnaire). As a simple matter of fact I believe it can be demonstrated that there are hundreds of voices as good as the best advertised ones, dozens of comparatively unknown orchestras that should be ranked near the top, and so on.

What I desire in radio is entertainment. If I wish education it can be secured from books and magazines in a fresher, more interesting, and more permanent form than by radio. I should like to hear a few great men talk over the radio just to discover how human they are—but the others can't ride on my electrons. Neither can

the flatted and fluttery vocalists, or the jazz-bos who keep time with a pick handle. I am interested in DX because if the set will bring in KDKA in daylight, or 4 QG at night, then I know that the machine is keeping step in a half-hearted manner, and will bring home entertainment if the weather will let it.

Even in this stationless part of the country nearly every wave carries two stations and a pack of coyotes. It is to weep.

ROBERT T. POUND.

LAVINA, Montana.

SIR:

Of all the "technical" journal's articles I like your facetious articles best of all. Your self-admitted ignorance is refreshing, as is your style of writing.

P. L.

SAN FRANCISCO.

SIR:

I think there is too much constructive criticism of the destructive type in your dept. "As the Broadcaster Sees It" is my preference.

F. H. S.

PITTSBURGH, Pennsylvania.

There seems to be some difference of opinion here!

WHAT THE LISTENER LIKES AND HOW HE LIKES IT

IN THE January and February RADIO BROADCAST a full page questionnaire appeared in this department which was answered in great detail by readers of the magazine. More than 1000 answers were received and the results are tabulated below.

It is difficult to interpret the results fairly, because we had answers from city dwellers in congested radio districts and from listeners in remote points, many miles from the nearest broadcasting station. Many answers were not definite but were interestingly qualified. It will be seen that the replies are classified according to the district from which they came. Metropolitan centers, such as New York, Chicago, and San Francisco, were separated from the others in the tabulation.

Among the many important conclusions to be drawn from this survey, perhaps the most impor-

tant is that, under present radio conditions, the city listener, especially in the large city, relies on his local stations for the most part, while those living some distance from the so-called "key stations" rely on DX. The comparatively few listeners who answered our specific question: Is the DX listener disappearing? gave conclusive reply that the DX listener is here now and for evermore. Another interesting conclusion is that "instrumental music" is favored as above all other classifications by more than 60 per cent. Serious music, so called, was most popular, although not overwhelmingly so.

The fourth question about the six most popular broadcasts received a variety of answers, which fell into three classes, as the tabulation shows. Our purpose was to discover what six broadcasts had attained great popularity. The

tabulation of this question shows that the regular feature or "hour" of greatest popularity was always the one which was broadcast over the largest number of stations. But the comparative popularity of broadcasts such as that of the Happiness Boys and Sam 'n' Henry is remarkable, for each feature is broadcast over but one station. In special events, sports broadcasts top the list. Among individual artists, the name of John McCormack appears most often, although that of Walter Damrosch is a close second.

After this tabulation was completed a large number of questionnaires were received which arrived too late to be tabulated and we regret that these could not be included. And to all those who sent in letters of comment and appreciation and the filled-out questionnaire, we offer our hearty thanks.—THE EDITOR.

The Results

1. Do you listen to your radio evenings as you would to a regular show, or do you simply turn it on and use it as a background to other activities?

	New York	Chicago	San Francisco	National
As a background	10	3	4	91
As a show	45	10	18	370
As a background except for features	80	17	40	448

2. Do you regularly tune-in on distant stations or do you regularly rely on your local stations?

	Locals only	Distance	Occasionally
Regularly rely on	65	13	19
Distance	25	8	27
Occasionally	40	5	14

(They tell us that the DX hound is a fast-disappearing breed. Is he?)

	Yes	No
Yes	1	0
No	3	3

3. If you had a hundred minutes to listen to all, or any part of the following broadcasts, how would you apportion your time?

Instrumental Music:	26.3%	30.1%	28.5%	23.3%
Serious	18	18.2	14.3	18.4
Light	16.6	14.8	16.1	17.4
Popular	60.0	63.1	58.9	59.1

	12.	13.6	13.2	12.6
Vocal Music	5.3	1.7	8.0	4.7
Radio Play	4.7	4.2	3.0	3.8
Speech	7.6	8.2	4.6	7.0
Educational Lecture	9.5	9.2	12.3	12.8
Miscellaneous Novelties				

4. What are the six best broadcasts you have heard?

Hours or Regular Events	
Atwater Kent	228
Victor Hour	128
N. Y. Symphony	93
Eveready	80
Boston Symphony	76
Maxwell Hour	53
A. & P. Gypsies	49
N. Y. Philharmonic	48
Whitall Anglo-Persians	47
Clicquot Club	44
Capitol Theatre	44
Ipana	40
Goldman's Band	38
San Francisco Symphony	33
Happiness Boys	31
Roxy	30
Royal Hour	28
George Olsen	28
Sam 'n' Henry	26
Zippers	26
KDKA Symphony	25
Balkite	22
Cook's Travelogue	19
Silvertown	19
Goldy and Dusty	18

Little Jack Little	18
Marine Band	18
Record Boys	16
Davis Saxophone Octette	15

Special Events

Dempsey-Tunney Fight	153
Inaugural N. B. C.	131
World's Series	124
Army-Navy Game	83
Coolidge's Inaugural	39
Radio Industries Banquet	39
Democratic Convention	38
Pershing's Farewell	31
Alabama-Stanford Game	28
Dempsey-Firpo Fight	20
Election 1924	13

Individuals

John McCormack	45
Walter Damrosch	39
Schumann-Heinck	33
Calvin Coolidge	30
Vincent Lopez	28
Joseph Hoffman	19
Will Rogers	18
Rev. Cadman	18
Reinald Warrenrath	17
Madame Homer	16
Marian Talley	16
Godfrey Ludlow	14
Mary Lewis	12
Mary Garden	12
Rev. Fosdick	10
Wendell Hall	10

Filament Lighting from the A. C. Mains

A Discussion of a Practicable Method for Batteryless Receiver Design—The Advantages of Series Connection of Filaments

By ROLAND F. BEERS

A NATURAL query when discussing the subject of series filaments is to inquire why such an arrangement is either necessary or desirable. This inquiry ably illustrates that growth of tradition which radio is rapidly accumulating. With a few exceptions, modern radio receivers up to the present time have employed the parallel filament connection. The filaments of the radio tubes have been operated from a constant 6-volt source, and variations of individual tube filaments have been made by changing the applied voltage.

It is not difficult to trace the reason for the prevalence of the parallel filaments scheme. In the beginning, audion filaments often required one or two amperes for each tube. A multi-tube set would therefore require 3 to 6 amperes. What better source of power was there, then, than the familiar 6-volt storage battery—a low-voltage, high current capacity affair? Its availability through the regular channels of distribution was assured, and everyone was acquainted with its operation and maintenance. As the first uses of the vacuum tube were determined by the amateurs, so were its tendencies bound to follow along their pioneer activities. It did not take long, therefore, for the 6-volt parallel filament scheme to become firmly entrenched in the minds of those who were to become radio set designers and builders of later periods.

In answer to the query concerning the system wherein radio tube filaments are arranged consecutively in series, it is first necessary to show why A batteries have not yet been completely eliminated by the use of the parallel filament scheme. Let us first consider the general principles of power supply, illustrated by the modern B-power unit. Here we have the customary transformer, rectifier, and filter circuit, as shown in Fig. 2. The current and voltage capacity of such a device is of the order of 85 mA. and 200 volts d. c. The degree of filtering of high-grade units of this type is such that a variation or ripple of but 0.1 per cent. is attained in the current output.

If high-quality reproduction is desired, with freedom from hum and "motor-boating," it is absolutely necessary that the variation in current supply be of this order. In order to achieve this degree of smoothing in plate supply devices, a filter structure of such design as is shown in Fig. 2 is used. The retail cost of a structure of this type is approximately \$20.00.

If we are to adhere to the same standard of quality with regard to the A power-supply source, it is also necessary that the current ripple shall not exceed 0.1 per cent. This statement has been theoretically demonstrated and experimentally verified, using an average radio receiver with no potentiometers which may be used to balance out any hum. With such a receiver the storage battery might be replaced with this theoretical A power-supply unit. Basing our judgment upon the design of the filter circuit shown in Fig. 2, we may in-

crease the values of the constants required until we obtain the same degree of filtering for 2½ amperes at 6 volts. Our structure will then look like Fig. 1. The weight of such a device would be approximately 300 pounds, and its cost, on the same basis as previously assumed, would average \$1500.00! For the reason of its weight and cost, it is therefore not feasible to effect A-battery elimination at 2½ amperes.

There are two main reasons why the series filament connection is so much more desirable from the power standpoint. The first reason is that the total current to be filtered is very much less than with the parallel system. With any number of tubes in series, the maximum current required is only that taken by one filament, and as the size and cost of filter chokes increases rapidly with the increase in the amount of current they are required to pass, we realize the economy possible by a reduction of current.

We are somewhat assisted by the fact that the

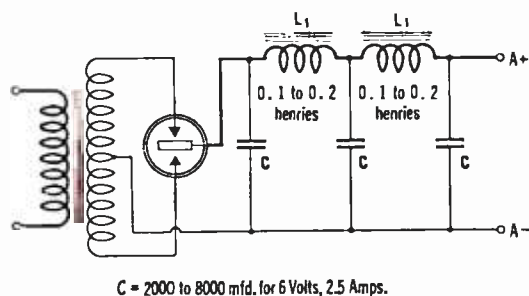

FIG. 1

filtering efficiency of a choke coil increases with the current through it; therefore, we should be able to design a more efficient filter system for A supply than for B supply, as far as the chokes are concerned. The amount of energy that can be stored in a given choke coil is equal to one half the inductance times the square of the current. In spite of this fact, however, there are other considerations which work to our disadvantage in the design of a high-current choke coil. For example, on account of the direct-current saturation of the steel core it is necessary to include large air gaps in high-current chokes. These air gaps reduce the effective permeability of the core to low values, making it necessary to increase the amount of copper and iron to large quantities, in order to attain sufficient inductance at high direct-current saturations. We are also limited in this consideration by the amount of copper

that can be used in a choke coil, on account of the d. c. resistance. If the choke coils have high d. c. resistance, the voltage output of a power unit intended for parallel filament supply would be much too large on a 3-tube set, for example, if the unit were designed to supply sufficient voltage for a 6- or 8-tube set. A power unit having sufficiently low regulation for parallel filament operation would therefore require monstrous inductances.

A second reason why the series filament connection is desirable is that higher voltages are available for filtering. For example, a 5-tube receiver with 100 tubes in series requires 15 volts for the filament supply, and an additional 15 volts may be advantageously employed for grid bias. Therefore, the total voltage required is 30 volts instead of 3 volts (grid bias is obtained from external batteries) for the parallel filament connection. Additional voltage is also available at the filter circuit by virtue of the fact that the A current is obtained through a series rheostat, the voltage drop through which may range from 100 to 150 volts (Regulation in this circuit has not the same importance as in the parallel filament scheme, because it is a constant-current system and not a constant-voltage system). The total voltage applied to the filter circuit is equal to the sum of these values or approximately 200 volts.

Now it is a matter of common knowledge that condenser efficiency in a filter circuit is much greater at high voltages than at low voltages. The amount of energy stored in a condenser is equal to one-half the capacity times the square of the voltage applied. Therefore, from this standpoint alone, a great saving is gained. For example, if a total capacity of 12 mfd. is required for a given degree of smoothing at 200 volts, the capacity required for the same degree of smoothing at 3 volts would be in excess of 50,000 mfd. The saving in inductance and capacity affected by the use of the series filament scheme is therefore enormous.

Fig. 3 shows a typical filter circuit for use in connection with 100 type tubes in series. This arrangement actually gives the same degree of filtering found in Figs. 1 and 2. Its cost is within reasonable limits, in comparison with other methods of power supply, while its size is not beyond the scope of average radio cabinets.

One obvious way in which to attack the problem of series filament connections is to place the vacuum tubes consecutively in sequence, in the same order in which they normally occur. That is, we may begin with the radio-frequency stages and run through the detector and audio stages. While this method may appear to be the most straightforward, it is open to several criticisms. In the first place, it has been demonstrated that less difficulty with hum will be experienced if the detector is placed nearest the B-minus or ground connection. Several different theories have been advanced to explain this situation, but the important fact to

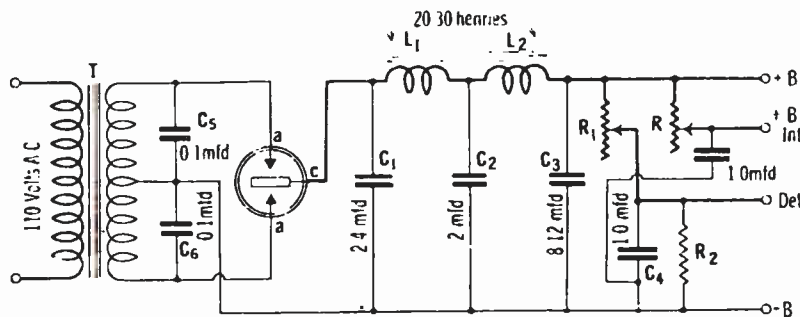

FIG. 2

the average set constructor is that a real advantage is gained by this position of the detector tube. A second difficulty frequently encountered in this method of series connection is that the proper values of negative grid bias are not always available. In certain commercial receivers, notably the Western Electric 4-B super-heterodyne, it is common practice to connect the grid return lead of those tubes requiring negative grid bias to some preceding filament in the series. This connection takes advantage of the voltage drop

Examination of the other filament circuits would indicate similar overloading. On account of these various difficulties involved, it was determined to make a study of the errors which existed in the straight series connection and to make such alterations as were required to bring the radio receiver to its normal operating characteristics.

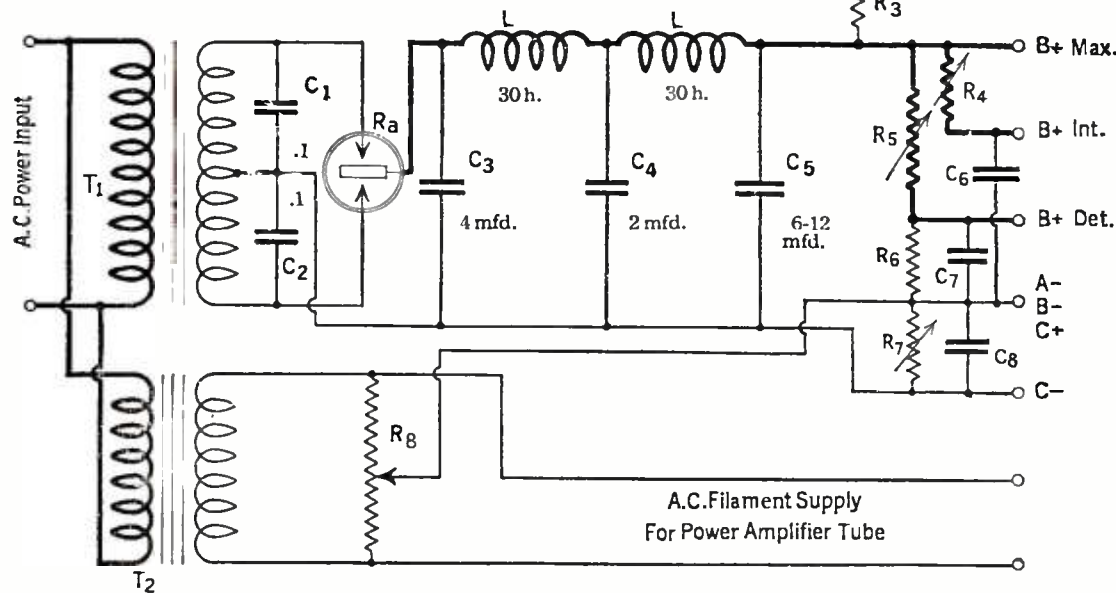

FIG. 3

in the filament circuit, and employs it as a grid bias. It can be readily demonstrated that while some of the tubes in the series will be benefited by such a connection, there will always be at least one of the tubes for which the required negative grid bias is not available. The third objection to the straight series connection is that all of the 199 tube filaments, with the exception of the first, must have some current overload in them, if the applied plate voltage exceeds 40 volts. For an analysis of this situation, see Fig. 4.

In this diagram, with no potential applied to any of the plates, the filament current ammeter, A, could be adjusted to read 60 mA., and the correct current would then be passing through each tube filament. However, when B voltage is applied to the plates, current flows in all the plate circuits, as indicated by the plate milliammeter, B. This current must return to the negative B. If we check the current in the filament for tube No. 3 at the point (b) we would find that it was carrying the regular filament current plus the plate current of tubes Nos. 1 and 2, because, as stated above, these plate currents must return to the negative B, and the most direct path is through the filaments. Consequently, the filament of tube No. 3 would be overloaded by an amount depending upon the plate current of tubes Nos. 1 and 2.

The data printed on the diagram, Fig. 4, give the amount of current in the filaments of each of the first five tubes. The amount of overload depends on the plate current of the preceding tubes. Thus, in the case of tube No. 3 (the 2nd audio stage). the overload is equal to the sum of the plate currents of tubes Nos. 1 and 2.

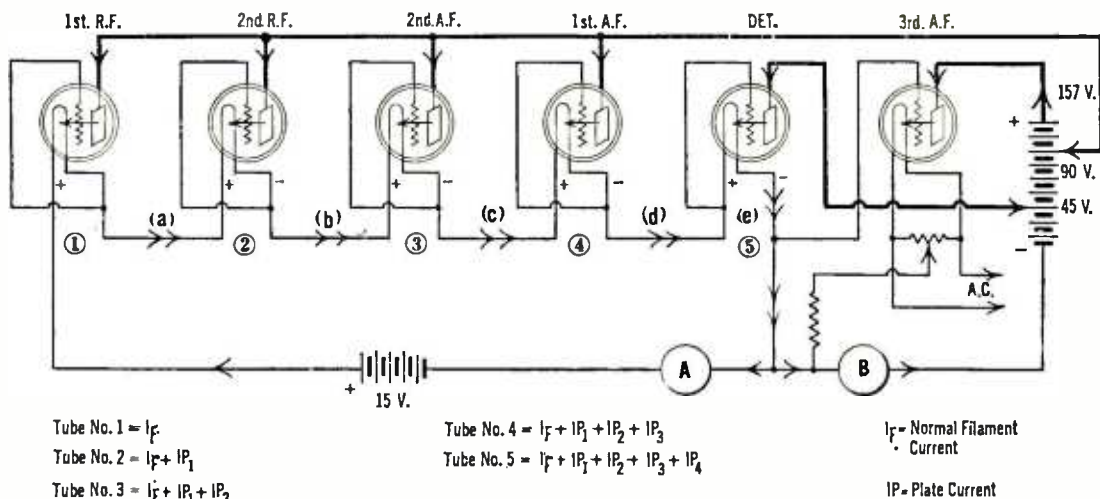

FIG. 4

The first step in this direction was to place the normal grid bias on each tube, with 90 volts on the plates of the amplifier tube and 45 volts on detector plates. It was frequently found that, if the various filament voltage drops were relied upon as the only source of grid bias, three difficulties arose. First, because of the need of a tube in the series ahead of each one requiring grid

bias, the number of available biases was insufficient. A receiver wired in this manner very frequently blocked completely in one or more stages on account of improper grid bias. When C batteries were inserted in these troublesome stages, amplification was again at normal values, but as this receiver was intended to be a batteryless set, other means of grid biasing were sought.

The second difficulty was encountered in the r.f. stages, where regeneration often occurred. In this situation the operator is unable to control his receiver on account of the incessant squeals and whistles of heterodyned carrier waves. A similar situation may also exist in a.f. stages. In this case it may cause an audio howl that will completely prevent reception.

The means finally adopted in obtaining correct grid biases was to place a 60- to 75-ohm adjustable resistance in series with each filament, for 199 type tubes, as shown in Fig. 5. This method is entirely satisfactory and has been used to some extent in Western Electric receivers. If adjustable resistances are used, the plate current of each tube can be set at the right value when final tests are made on the receiver. Fixed resistances may be used, however, if the constructor does not want to make this refined adjustment. The plate current of each 199 type amplifier tube can be reduced to about 2.2 mA., with 90 volts on the plates.

When the 60-ohm resistances were placed in position in the filament circuit, it was found that there was no tendency to regenerate, as out-

lined above. From a study of Fig. 5 it may be seen that r.f. currents in tube No. 1 must traverse the filament of tube No. 2; likewise, those currents in tube No. 2 must pass through the filament of tube No. 5. The question might arise whether or not this would be a source of regeneration. It was found, however, that the inclusion of the 60-ohm resistances in the grid circuit of

the respective tubes was of the proper value to eliminate the tendency to oscillation. This phenomenon is a well known fact, and in many modern radio receivers a resistance is deliberately included in the grid circuit for the purpose of stabilizing the tendency to oscillate. The principle involved here is that, if the resistance of an oscillatory circuit is of sufficiently large value, sustained oscillations

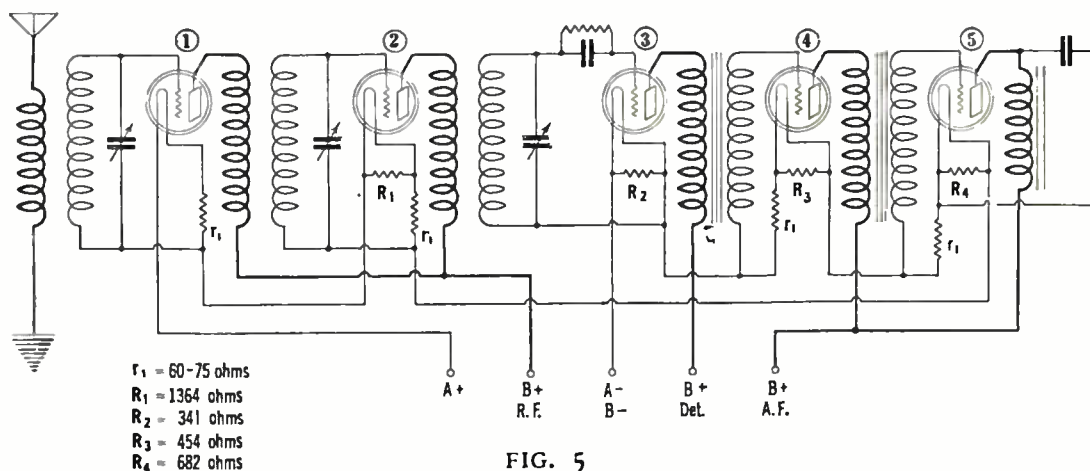

FIG. 5

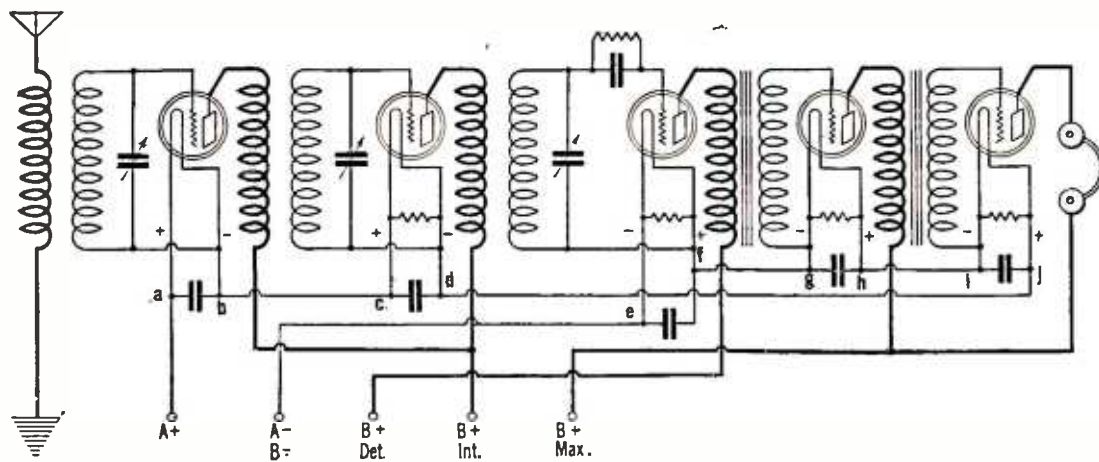

FIG. 6

cannot be produced therein. Such a circuit is said to have a high decrement.

When the series filament receiver had been provided with proper grid biasing, as described, it was found that its performance was at least equal to that of a similar set with parallel filaments. This particular receiver had two stages of tuned r.f., detector, and three stages of resistance-coupled a.f. amplification. Five UX-199 tubes and one UX-112 power tube were used. A filament battery of 36 volts was employed feeding 60 mA. to the set. A plate battery of 157 volts delivered a total current of 22 mA.

If the results of Fig. 4 are now applied to the set in consideration, it is readily seen that the filaments of all the 199 tubes in series, with the exception of tube No. 1, will carry a current which is in excess of 60 mA. The excessive current in the last tube in the series may rise to a value which is 30 per cent. above the normal value. The actual current overloads may be computed by reference to the table on this page. In this table, the overload figures are obtained by deducting 60 from the filament-current figures given in the second column of figures. These data are based on the assumption that all tubes have proper grid bias, that amplifier tubes are provided with 90 volts on the plates, and that detector tubes have 45 volts on the plates. This arrangement will give a plate current in each amplifier tube of approximately 2.2 mA., while that of the detector tubes will average 1.0 mA.

A very simple and satisfactory method of reducing the filament current overload is to shunt a bypass resistance across each filament, as shown in Fig. 5. These resistances do not all have the same values, and their proper size, for 199 tubes, is determined as follows:-

$$R = \frac{3}{\text{Excess Filament Current, Amperes.}}$$

For example, the last tube in a 6-tube series was measured, and its filament current was found to be 71 mA. The excess filament current is therefore 11 mA., or 0.011 amperes. The correct value of the bypass resistance is then equal to $\frac{3}{0.011}$, or 273 ohms.

The table shows the correct values of bypass resistance to be used in various combinations of 199 tubes.

When the receiver has been provided with the correct biasing resistances and filament shunts, it is now ready to be connected up for use. If the receiver is to be used in connection with an electric power supply device, it may be necessary to take additional precautions to prevent "motor-boating."

For the present discussion, the following rules summarize the procedure in laying out a series filament receiver using 199 tubes:

1. Wire all filaments in series, including a 60-ohm resistor ahead of each amplifier tube for grid bias. (see Fig. 5).

2. Choose the proper order of wiring the filaments, so that the detector is next to the B minus or ground connection.

3. Place shunt resistances across each filament, as shown in Fig. 5.

The foregoing discussion is based upon a plate voltage of 90 volts on all amplifier tubes, so that large signal voltages may be applied without distortion. Under this condition it is necessary that a negative grid bias be obtained in some manner for these tubes, such as by the use of the 60-ohm

resistances in series with each amplifier filament. It is entirely possible, however, to build a satisfactory series filament radio receiver without the use of these 60-ohm resistances, for use on moderate volumes. In this case it is essential that the amplifier plate voltage shall not exceed 50 volts, so that the average plate current will lie between 2.0 and 2.5 mA. This situation frequently prevails in radio-frequency stages where the signal voltage is low enough not to warrant the use of a high negative grid bias, and also in resistance-coupled a.f. stages where the actual voltage on the plates is frequently of the order of 40 volts.

In such cases as these a very simple procedure may be followed—that of connecting the grid return leads to the negative leg of the respective filaments, as shown in Fig. 6. It is, of course, apparent that the use of shunt resistors across each filament is always necessary, in order to prevent current overload. It will also be advisable to provide some means of stabilizing the r.f. amplifier, thus preventing the tendency to oscillation. The inclusion of the 60-ohm biasing resistances reduces this tendency to a very low degree, but without their use, difficulties are at hand. A satisfactory means of overcoming this situation is to bypass these r.f. currents through a 0.1-1.0 mfd. condenser shunted across each filament, as shown in Fig. 6. The use of these bypass condensers insures complete control over the receiver at all times and affords a greater possibility of high-quality reproduction.

TYPE OF SET	ORDER OF TUBES	PLATE CURRENT, MA.	FILAMENT CURRENT, No SHUNT. MA.	SHUNT RESISTANCE.
3-TUBE REGENERATIVE 3-199's	2nd a. f.	2.2	60.0	None
	1st a. f.	2.2	62.2	1364
	Det.	1.0	64.4	682
BROWNING-DRAKE 3-199's; 1 UX-112 ON A. C.	1st r. f.	2.2	60.0	None
	1st a. f.	2.2	62.2	1364
	Det.	1.0	64.4	682
BROWNING-DRAKE 4-199's; UX-112 ON A. C.	1st r. f.	2.2	60.0	None
	2nd a. f.	2.2	62.2	1364
	1st a. f.	2.2	64.4	682
	Det.	1.0	66.6	454
T. R. F. 4-199's; 1 UX-112 ON A. C.	1st r. f.	2.2	60.0	None
	2nd r. f.	2.2	62.2	1364
	1st a. f.	2.2	64.4	682
	Det.	1.0	66.6	454
T. R. F. 5-199's	1st r. f.	2.2	60.0	None
	2nd r. f.	2.2	62.2	1364
	2nd a. f.	2.2	64.4	682
	1st a. f.	2.2	66.6	454
	Det.	1.0	68.8	341
T. R. F. 5-199's; 1 UX-112 ON A. C.	1st r. f.	2.2	60.0	None
	2nd r. f.	2.2	62.2	1364
	3rd r. f.	2.2	64.4	682
	1st a. f.	2.2	66.6	454
	Det.	1.0	68.8	341
T. R. F. 6-199's	1st r. f.	2.2	60.0	None
	2nd r. f.	2.2	62.2	1364
	3rd r. f.	2.2	64.4	682
	2nd a. f.	2.2	66.6	454
	1st a. f.	2.2	68.8	341
	Det.	1.0	71.0	273
SUPER-HETERODYNE 8-199's	1st i. f.	2.2	60.0	None
	2nd i. f.	2.2	62.2	1364
	3rd i. f.	2.2	64.4	682
	1st Det. Osc.	1.0	66.6	454
	2nd a. f.	2.2	68.6	348
	1st a. f.	2.2	70.8	277
	2nd Det.	1.0	73.0	231

1. Wire all filaments in series, including a

AS THE BROADCASTER SEES IT

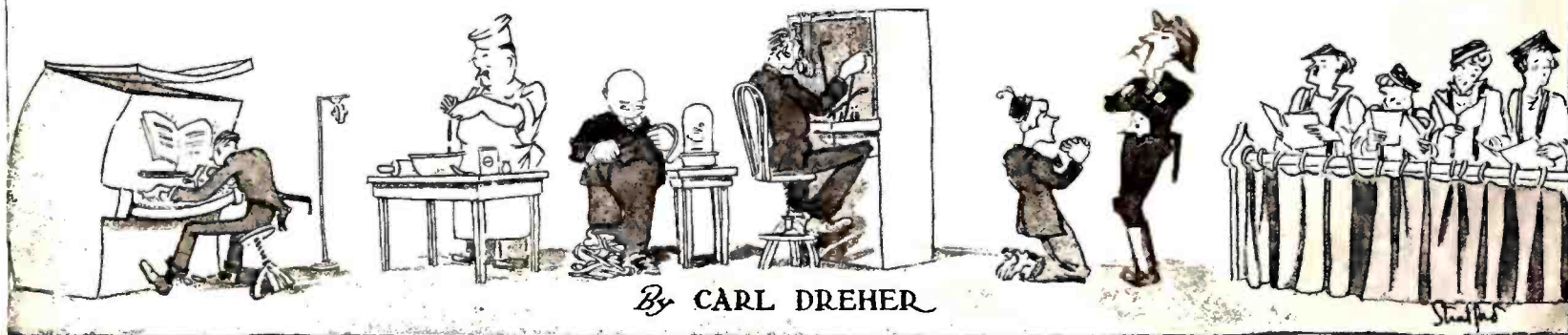

Drawings by Franklyn F. Stratford

One Explanation for the Plethora of Broadcasting Stations

FOR some time, as the number of broadcasting stations in the United States mounts toward the thousand mark, I have been wondering where they all came from, and what process caused them to multiply. Did they reproduce by simple cell division, like the amoeba? Did they cast spores over the countryside, which, falling on fertile soil, took root and became new transmitters? Or was it necessary to mate a pair of them in order to produce a third? Whatever the mechanism, I have found one of the sources of their nourishment, which heretofore I had overlooked. In small towns, it may well be the principal urge leading to expression in kilocycles. It is the booster spirit, the "Bigger and Better Blattville" pressure which all but blows off the safety valve in the would-be metropolis of the inland states. Among other activities, it builds broadcasting stations.

The rivalry between country towns, while usually good-natured, is exceedingly intense. When it goes so far as to lead to the posting of signs about the town, urging the citizens to buy round-trip tickets at the local railroad station, in order that the total for the year may be higher than the ticket sales of some rival settlement down the line, it is apt to extend to all the other activities of community life. One of these is broadcast reception—and transmission. Some village of 2000 out on the plains possesses a broadcasting station, perhaps by accident. A manufacturer of babies' diapers, say, has erected it to advertise his product. Incidentally, he advertises the town. The next village, with 4000 population and a natural feeling of superiority, feels an irresistible impulse to have a broadcasting station bigger than the diaper broadcasting station. The local manufacturer of varnished pretzels thinks he might take a whack at it. His primary object is, of course, to advertise his varnished pretzels. But he also wants to shine at his luncheon club among his fellow business men. He wants to be slapped on the back by the President of the Chamber of Commerce. He wants to be pointed out as a benefactor of the town. These considerations weigh with him as much as his itch for gold. No doubt they are the determining factor in many cases where a station stays on the air although it is actually losing in

dollars and cents. The boosters must broadcast. Some of them are even willing to hold the bag for a while, as a matter of civic pride.

In some cases the stations actually receive community support through the local Chamber of Commerce or some other semi-official or official agency. Then, of course, there are municipally owned and operated transmitters, such as those of Atlantic City, New Jersey (WPG), and New York City (WNYC). Whether municipally maintained or not, broadcasting stations tend to function as the mouthpieces of their respective communities—"The Voice of Whatever-It-Is" being a common slogan derived from this rôle.

Of course there are very definite limits, economic and electrical, to this process of community-magnification by radio. The towns may compete all they like in fire engines, railroad ticket sales, and fraternal orders; such matters are their own business. But radio knows no county lines, and there is no such thing as one's own business when it comes to letting loose ether waves of frequencies between 10 and 50,000 kilocycles per second. Furthermore, to plant a broadcasting station in every township is about as rational a procedure, economically, as maintaining a dozen telephone systems. In wire telephone systems, for reasons too elementary to require statement, unity is the aim. And right there we have the answer to the broadcasting problem as it affects the civic ambitions of the smaller towns. Instead of Podunk having

its own precious twenty-watt squeaker manipulated by one of the local apprentice electricians, and Peadunk, fifteen miles away, competing desperately with a twenty-five watter, let Podunk and Peadunk and a few others, if they *must* broadcast, contribute toward a common transmitter, and maintain studios connected to it by wire lines. There is plenty of No. 12 copper running on poles over the countryside, and, at any rate, one transmitter with a half-dozen studios is better than six transmitters with one studio apiece.

Broadcasting and Social Upheavals

ABOUT a year ago the British general strike flared up, ran its course, and came to an end. Maybe it was the last general strike of this industrialized world, but it takes a confirmed optimist to believe that. If it should come to pass again, whether in the British Isles or on some other portion of the globe, what part will be played by radio broadcasting, the latest and most rapidly developing of all the means of mass communication?

The British conflict afforded some indications of what may be expected to happen in the future. Once the battle was on, the regular newspapers either ceased publication or were reduced to little more than handbills. The government published a newspaper of its own, the *British Gazette*, in opposition to the *British Worker*, representing the Labor side. Judged by normal newspaper standards, neither paper was a shining star. But they were about all that remained of British journalism. Piling transportation difficulties on to the confusion in the newspaper plants themselves, the strike raised hurdles too high to surmount. Had it not been for the chain of the British

Broadcasting Company, with its principal stations at Aberdeen, Belfast, Birmingham, Bournemouth, Cardiff, Glasgow, London, Manchester, Newcastle, and Daventry, the public would have been practically uninformed during the early days of the strike. At such times the tide toward panic runs swiftly. In the absence of reliable information, sensational rumors spring up and circulate rapidly, gaining horrors, by a well-known process of accretion, as they go



"HE ALSO WANTS TO SHINE AT HIS LUNCHEON CLUB"

along. An agency which helps to keep people's feet on the ground, at such a time, is performing no small service. This is substantially what radio broadcasting did in England during the crisis of May, 1926.

Let it be emphasized that our discussion is concerned with the function of broadcasting during times of grave social disturbance in industrial communities. During normal periods, broadcasting occupies a field quite distinct from that of journalism. Since fairly normal periods, until the world gets a good deal worse, may be expected to cover 0.999 of the total time, the newspapers are in a secure position. Their facilities for news-gathering and catering to the interests of great masses of people are in a class by themselves. Broadcasting, in quiet times, interferes with the newspapers about as much as the theatres do; that is to say, not at all. If a man intends to go to a show in the evening, or to listen to his radio, he reads his morning and evening papers just the same.

But when there is an acute industrial crisis, the tables may be turned temporarily, as the British strike showed. The reason lies in the contrasting conditions of news dissemination by radio telephony and by printing. Publishing a modern newspaper of large circulation is a formidable project. We do not realize what a huge undertaking it is merely because we are accustomed to it. The thing has been organized and built up on such a scale that we feel it must come around every morning, like the sun. That is a palpable mistake. The newspaper is produced by the concerted action of hundreds or thousands of men. If the men quit, there is no newspaper.

Even if the newspaper is produced, it means nothing unless the distribution system remains intact. Modern newspapers are bulky. One copy does not weigh much, but try lifting fifty and then visualize the motor trucks and mail cars required to transport fifty thousand. Reduce the size, and you have ameliorated the difficulty, but you cannot remove it. Paper is gross matter, subject to the physical limitations of physical things.

Contrast the radio telephone station. Instead of hundreds of workers, it requires only a handful of men. A station of 1000 watts output is considered fairly large; its night program coverage in an urban district is, in fact, comparable with that of a good sized newspaper's circulation—say 100,000 listeners. Plenty of 500- and 1000-watt stations with the studios, control room, and power plant in close proximity can be, and are, run by one technician. One of the largest broadcasting plants in the world, with forty or fifty field points, and the studios and radio power plant separated by thirty-five miles, is operated by a technical staff of sixteen men. In a pinch, with the field work tossed overboard, the two engineers in charge, whose functions in normal times are mainly administrative, could run the whole plant alone. They might need a wire chief for the lines connecting the studio and radio station, but a telephone engineer could substitute for the wire chiefs if the latter all went out on strike. In short, three or four professional men, who are likely to be on the "White" side in a serious industrial conflict, can operate the largest broadcasting stations, and one or two men each can take care of the rest. They might not turn out a one hundred per cent. transmission job, but that is beside the point. The station would radiate and say what the proprietors wanted it to say.

The second factor, that of transportation, presents an even more striking contrast. A broad-

casting station generates its own "carrier," as the high frequency wave is aptly termed. Its content is not printed on a few ounces of paper or other tangible medium. It is of the nature of radiation—weightless, impalpable, invisible, and, once released, it penetrates to every point within range of the station without the aid of a single man or vehicle. In distribution, even more than in production, the radio is free where the newspaper is shackled, when the men walk out.

Not very many powerful radio stations are required to cover a country of moderate area. In Great Britain a single high-power station, Daventry, of twenty-five kilowatts rating, can cover the entire island kingdom. Countries like France and Germany are similarly protected. Even in the United States a single fifty-kilowatt station located in the North-East can provide usable service, in daylight, for South-Eastern Canada, New England, New York, Pennsylvania, New Jersey, Maryland, Delaware, the District of Columbia, and the Virginias, with a possibility of service to regions beyond. The daylight range of such a transmitter is about 400 miles. The population of the area of a circle of this radius, in this part of the United States, is of the order of thirty millions. Three or four such stations strategically placed over the country, getting

ply for a 500-watt station. A gasoline driven alternator of two hundred and fifty kilowatts capacity would supply the largest broadcasting station in existence at the present time. Such a machine is readily obtainable, and might be included as an integral part of broadcasting plants whose continuance in operation is vital. As for the telephone lines connecting studio and power plant, the former being located in the city and the latter rurally, a detachment of infantry with a few motor cyclists, could safeguard twenty miles of aerial cable without special difficulty. And in many instances the stretch of wire is short. In New York City, for example, there are two five-kilowatt stations with studios practically adjacent to the power rooms. The assailability of radio stations, even if overt force is employed, is not greater than that of water works and similar utilities, and far less than that of newspapers. As for the telegraph circuits on which the radio stations would have to depend, in the main, for news—armies and navies usually maintain very effective radio telegraph systems. In the United States there would be no insurmountable difficulty on that score.

But, it may be objected, when the radio speaks, its words go in at one ear and out at the other; it lacks the relative permanency of the printed phrase. This defect is of only moderate consequence. For the general public the newspaper certainly contains no element of permanency; it lasts a morning or evening and goes into the fire. The readers remember principally the headlines of the articles which interest them. These salient points are impressed just as well by oral communication, and, by frequent repetition, or by some coördination of printing with radio, the defect may be overcome entirely. For example, in New York City, several hundred police booths and precinct station houses are being fitted out with receiving apparatus capable of responding selectively to the municipal radio broadcasting station. During periods of civil disturbance, these official receiving posts could be utilized as secondary distribution points for news, with no more additional equipment than simple lettering materials for printing bulletins. Such ideas have their ramifications, which we need not trace in this sketch; the developments will follow when the necessity for them arises.

Against the limitations of radio broadcasting, even admitting them to be more serious than they actually are, we must balance the directness and speed of this form of communication. When the radio

audience receives blow-by-blow descriptions of prize fights, the impulse of pain has scarcely passed along the nerve paths of the man struck before the radio listeners know as much about it as he does. This quality of immediate contact, as opposed to the tedious mechanical interventions of printing, is of special importance at times when event follows event and conditions change from hour to hour.

The next general strike, wherever it bobs up, will provide food for further reflection. It is a plausible guess that we shall hear more than we shall see, and that our listening will be done at the orifices of loud speakers.

Glad Tidings from the West

A CLIPPING kindly contributed by Mr. Zeh Bouck to this department reveals astounding leaps forward in the progress of the radio art, as set down for posterity in the Santa Cruz *Morning Sentinel*. It is entitled: "Of

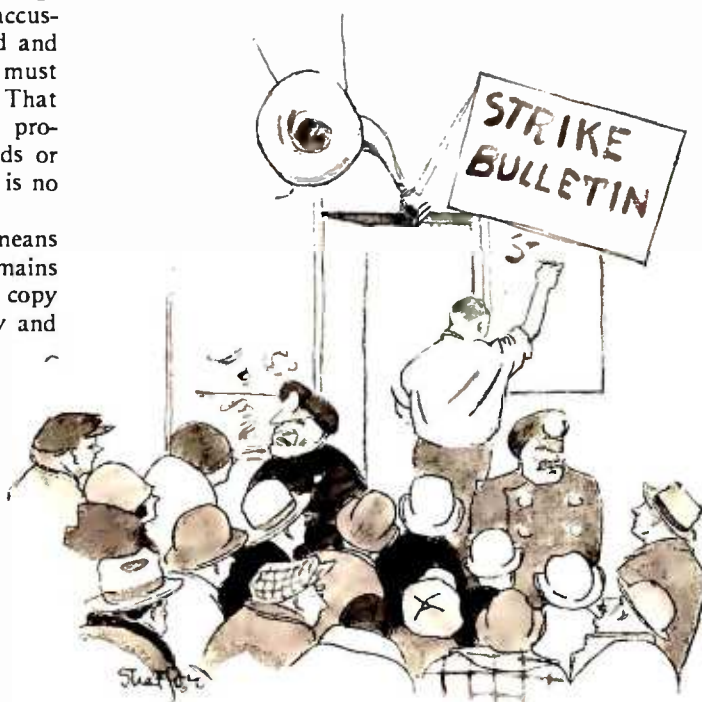

"OUR LISTENING WILL BE DONE AT THE ORIFICES OF LOUD SPEAKERS"

news over telephone or telegraph lines remaining in service, or by airplane if the worst comes to the worst, could solve the problem even in the United States. Of course, not every family, even in such industrialized countries as the United States and Great Britain, owns a radio receiver. But millions of them do, and each set is potentially a focus of information when information is hard to get by other means.

The weaknesses of radio distribution of news fall under two heads: First, physical vulnerability analogous to, but less serious than that of the newspaper; second, the limitations of the spoken word, as such. The first division may in turn be considered under two subheads: Power supply and wire connections. A broadcasting station requires electric power, normally obtained from central stations. During a general strike this power might not be available. But the amount required is not excessive, being in the ratio of five or six times the energy output of the transmitter. Ten horsepower would be an ample sup-

Interest to All DX Fans." Only one paragraph need be lifted:

The inventor's claims regarding the application of polarized harmonics was (sic) a little too deep for the writer but to demonstrate what he meant he tuned in kxw where Mr. Meehan was singing an Indian song and by manipulation of the loop he entirely eliminated the accompaniment, also reversing the situation by bringing the accompaniment up so loud that it interfered with the singer. Another demonstration on an orchestra was the elimination or making of the string instruments predominate at will. On a mixed duet the soprano could be almost completely tuned out leaving the tenor singer predominating and vice versa. Altogether, the demonstration was very remarkable.

The only comment I can think of is: "You bet!"

The Radio Club of America

FOR one evening each month, in the large lecture room of Havemeyer Hall, at Columbia University, the portrait of the venerable James Renwick, LL. D., Professor of Natural Philosophy and Chemistry, 1820-1854, looks down on a group of young men, and some older ones, gathered to discuss a subject which did not exist during his life. There are a hundred of these young men, more or less. They talk about power packs, loud speakers, short-wave transmitters, tendencies in modern radio receivers. The portrait of Professor Renwick, who lived while Clerk Maxwell was evolving the electro-magnetic theory, seems to bear a slightly puzzled frown. But the members of the Radio Club of America never look up at him. He is too far back for them. Their thoughts sometimes regress to the early days of radio, to the year 1909, say, when the Club was founded. In radio that is a long time. Radio men think mainly in the present; they find plenty there to occupy them.

The Club has two principal objects—one concerned with the engineering aspects of the radio art, the other with the perpetuation of the amateur tradition. The Year Book for 1926 states: "The Club now has among its members many prominent scientists, inventors, and engineers, as a glance at the membership list will show. However, it is always anxious to embrace amateurs of the present day, in order that its membership shall never lack the renewed life given by embryo scientists." It is primarily an amateur association, as the Institute of Radio Engineers is fundamentally a professional body. Amateurs and professionals belong to both organizations, but the Radio Club members never forget that they were or are radio amateurs, while the members of the I. R. E., carrying the burden of radio scholarship, seldom forget that they are professionals.

The Club now has some 400 members, of whom 108 are of Fellow grade. Fellows qualify by five years of membership in the Club or by

contributions to the radio art, at the discretion of the Board of Directors, the governing body. It consists of a President, Vice-President, Treasurer, Corresponding Secretary, Recording Secretary, and thirteen Directors. The officers and seven Directors are elected annually by the membership; the remaining six Directors are elected by a majority vote of the newly constituted Board of Direction at its first meeting. This year, the President of the Club is Ernest V. Amy; C. R. Runyon, Jr. is Vice-President. Past Presidents are W. E. D. Stokes, Jr., Frank King, George J. Eltz, Jr., Edwin H. Armstrong (1916-1920), and George E. Burghard (1921-1925). Mr. Amy was re-elected in 1926 for the present year.

Among the authors who have presented papers before the Radio Club of America are included Armstrong, Farrand, Van Dyck, Weagant, Hazeltine, W. C. White, Godley, Conrad, Heising, Aceves, Clement, Morecroft, Grebe, John Stone Stone, Lowenstein, Dubilier, Goldsmith, Marriott, Logwood, Pacent, and Hogan. The complete list is a formidable one, and the names above represent it only partially. As



AT A RADIO CLUB BANQUET

Seated at the table, from left to right: George H. Clark, E. E. Bucher, Gano Dunn, Edwin H. Armstrong, Michael I. Pupin, E. V. Amy, George J. Eltz, Jr., David Sarnoff, George Burghard, John L. Hogan, Paul F. Godley

early as 1912 the members of the Club were talking about square-law variable condensers and directional radio transmission. The value of the papers presented, to the radio art as a whole, has been inestimable. They form a contribution to the engineering literature second only to the collected *Proceedings of the Institute of Radio Engineers*. Incidentally, these papers are printed in RADIO BROADCAST.

The discussions following the presentation of papers are lively and informal. Nobody tries to display his knowledge and no one is afraid to show his ignorance. The attitude is simply that of a group of men vastly interested in radio, whether or not they are making any money out of it, who meet once a month to talk about the subject which happens to entertain them most.

And now, what course is to be charted for the future? Will the Club remain a sort of junior engineering society, or will it become a club literally? One plausible guess is that the organization will become a club in fact as well as in name, within the next few years, but without sacrificing its technical status. The two rôles are in no way incongruous. The formation of some sort of radio club in New York City, with permanent quarters, is obviously within reach.

The Radio Club of America has the name. It is a going concern. It has a membership of 400 at this writing. An inspection of the 1926 Year Book reveals that 78 per cent. of the members therein listed reside in New York City or its suburbs. But it is not a club, as yet. It maintains an office at 55 West 42nd Street, New York City, but it has no lounging rooms where the members can guzzle bottles of cool ginger ale, boast about their distance records of fifteen years ago, recall fondly the days when Doc. Hudson called FNK with a service on 600 meters to remind John V. L. Hogan that he had left his pipe at the Doctor's house the night before, and consummate million dollar deals. If half the present membership wanted a club, it could be started on a modest scale, this year or next. Such a development, of course, would not interfere with the monthly technical sessions, and technical membership on the present order, with dues of \$3 and \$5 a year, could be retained for those not interested in the proposed aspect of the Club's activities. No one who has attended meetings of the Club, or been entertained at one of its annual banquets, can doubt that the organization has the vitality

and energy necessary to take the lead in this enterprise. Steps have already been taken in this direction. It is interesting to note that the Club has recently appointed a special "House Committee" for the purpose of investigating the desirability of such an understanding and to submit recommendations for organization and financing. A modest Club House, with comfortable lounging room or rooms, is planned. The radio men in and around New York will await developments with much interest, now that the wheels have actually begun to turn.

Technical Operation of Broadcasting Stations

15. Volume Indicators

THE sight of a milliammeter in the plate circuit of an overloaded tube, its needle fluctuating violently, is familiar to every broadcast operator and engineer. When the tube is in the speech circuits of the transmitter the sight, for obvious reasons, is a deplorable one, but the principle, or something on its order, is valuable for preventing the very overloading which the fluctuating milliammeter shows. This is when it is embodied in the instrument called the "volume indicator," much used in broadcasting as a visual guide in setting energy levels.

Before going into the description of one type of volume indicator I should like to make it clear that it is an indicator, as the name implies, rather than a measuring instrument. Basically, the instrument is an alternating current voltmeter, and in certain forms it may be calibrated as an accurate low-reading instrument of this class, extremely useful in telephone and radio work for measuring audio potentials. Again, it may be designed and calibrated to measure tele-

phone levels in TU's. The form shown in Fig. 1, however, is intended primarily as an indicator.

The input transformer shown may be an audio amplifying transformer, preferably with a high-step-up ratio (1:10 or 1:5). The primary impedance must be sufficiently high so that, even at low frequencies, the instrument will not affect circuits of about 500 ohms impedance, across which it is bridged. This means that at 100 cycles the primary of the transformer should have an impedance of 20,000 ohms, which requires 40 henrys inductance, approximately. The secondary of this step-up transformer feeds a vacuum tube, which may be of the UX201-A type, or its equivalent. The grid of this tube is biased negatively to about 10 volts, so that the plate current, measured on a milliammeter, MA., of 0-10 range, is only about 0.5 milliamperes with 90 volts plate potential. A filament voltmeter is provided to keep the voltage across the filament constant.

The theory of operation is as follows: Through the negative biasing of the grid, the tube is being worked so far down on the curve that when the transformer secondary contributes a further negative potential to the grid the plate current is only insignificantly reduced. See the characteristic curve of Fig. 3. On the other hand, positive potentials carry the current up on to the steep portion of the curve once more, resulting in a flick upward of the milliammeter pointer. The amplitude of this movement indicates the magni-

short of transmitter overloading, is 5.0. Then it is the control operator's business not to allow his peaks on the volume indicator meter to hit more than 5.0, and, even if he does not know the absolute value of the r. m. s. audio voltage he

sufficiently on the second tube, which is the volume indicator proper. Both in the one- and two-tube outfits, various combinations of transformers, tubes, and indicating instruments may be utilized. An ordinary amplifying transformer of 1:3 or 1:5 ratio, a high-mu tube, and a galvanometer of about 1.5 milliamperes full scale reading, is a good single-tube combination. The voltages may be about the same as with the high ratio input transformer, UX-201-A tube, and 0-10 milliammeter described below. Mr. W. K. Aughenbaugh sends in a sketch of a volume indicator using two UX-112's, 45 volts plate, no grid bias, ordinary amplifying transformers, and a 0-10 d.c. voltmeter as an indicator. A swing from 2 to 6 on the meter gives him the proper modulation on the WFBG transmitter, which he runs. This is not really an orthodox volume indicator, and it would be improved with the negative bias feature, but it serves the purpose. Since the instrument is used only as a level indicator, the proper limits of operation having been established by listening checks on quality and overload observations in the amplifiers and transmitter, the operators at each

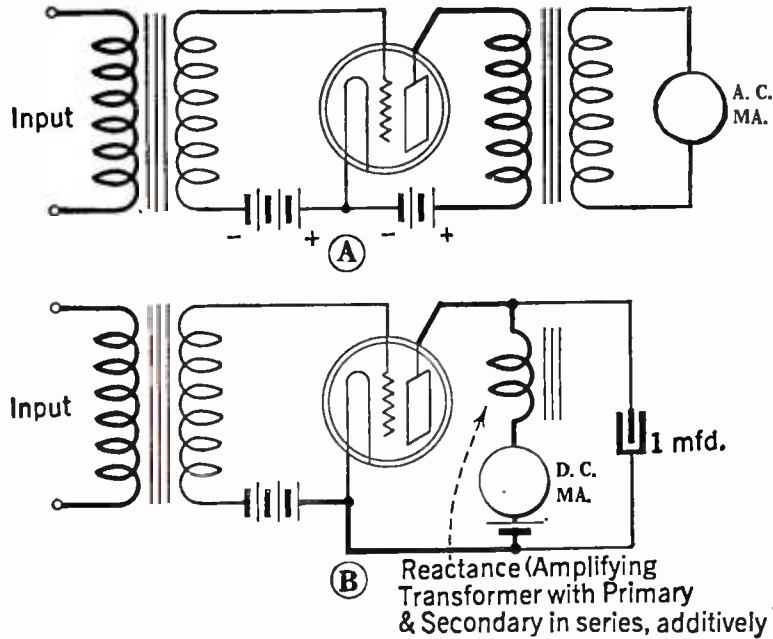

FIG. 1

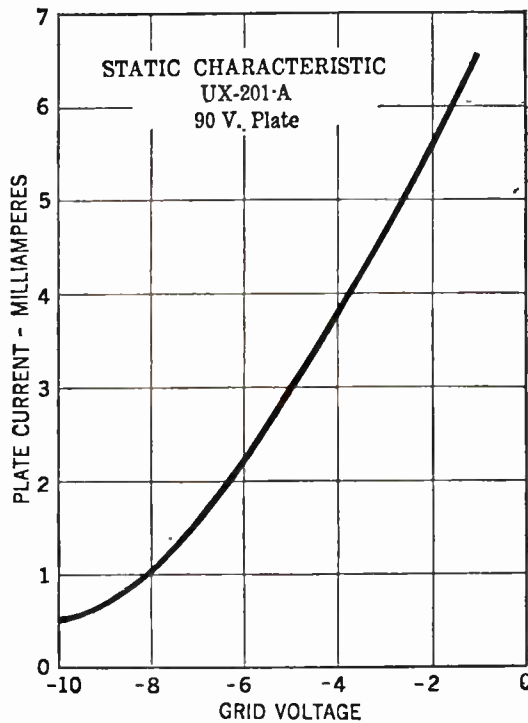

FIG. 3

is putting out on the line, the volume indicator gives him something to go by, and he is far better off than if he were trying to regulate his output only by ear.

Just as loud speakers may be coupled to the plate of the last tube through an output transformer, so an a.c. milliammeter or galvanometer in a volume indicator may be connected in the same way. The instrument then reads only the audio variations in the plate circuit of the tube, the pointer being at zero in the intervals, while when a d.c. milliammeter is directly connected in the plate circuit there is always a residual reading of a fraction of a milliamperes even when there is no modulation on the circuits. Fig. 1A shows the connection with an output transformer, 1B with a choke-condenser connection, which has proved effective in practice.

For increased range and sensitiveness, volume indicators are sometimes built with two tubes, the first stage being an audio amplifier to bring up low voltages to a point where they can register

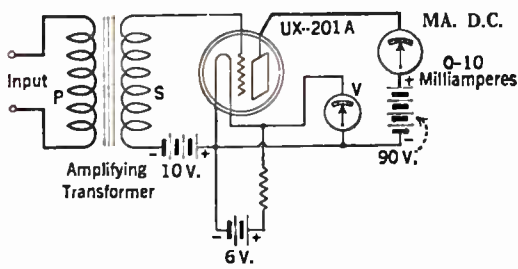

FIG. 2

tude of the alternating potential impressed on the grid, and hence, divided by the transformer voltage ratio, the audio potential on the line across which the volume indicator has been bridged. The device is merely a special form of rectifier. Fig. 4 is a table, in which columns 1 and 2 are taken from the characteristic curve of Fig. 3, showing the variation of plate current with grid potential. Column 3 shows the plus rise in voltage calculated from the base point, which is the negative grid bias potential, 10 volts in this case. Column 4 is this figure divided by the transformer ratio, assumed as 10; this gives us a rough measure of the audio voltage across the input of the instrument. By tapping various potentials along the grid bias battery one may calibrate a volume indicator, for comparative purposes, in this way. The results should not be taken as absolute values, because the response characteristic of the meter, the terminal conditions in the circuit being measured, and other factors, all affect the readings. However, these unknowns may be disregarded when only indications are required. For example, with a tube of normal emission in the volume indicator, and proper filament and plate voltages, it may have been ascertained that, when the volume indicator is bridged across the line leading to the radio station, with given settings there, the maximum allowable deflection of the meter,

GRID VOLTS	PLATE MILLIAMPS.	POSITIVE GRID SWING VOLTS	INPUT VOLTS *
-12	0.3		
-10	0.5	0	0
-8	1.0	2	0.2
-6	2.25	4	0.4
-4	3.75	6	0.6
-2	5.6	8	0.8

* With 1:10 Input Transformer Ratio

FIG. 4

station may utilize whatever apparatus is handy and indulge their fancy for experimentation at the same time.

Something About Gain Control

FOR the edification of any members of the operating fraternity who may not have thought about the matter of proper gain regulation, I would point out a fundamental difference in methods. The wrong way is to cut down sharply on excessive peaks. The right way is to bring up the gain moderately on pianissimo passages, reducing it once more to a safe level before or at the beginning of the next crescendo. That is, a skilled gain operator works with a certain base level, set for the particular soloist or ensemble being broadcast as being within the overload limits of the amplifier and transmitter. He brings up the gain cautiously on low portions of the music. He does not have to cut down in a panicky fashion on peaks, because his base level is set to take care of peaks. This ideal procedure requires, in practice, familiarity with the artist's volume range and the score, which can generally be acquired only through a rehearsal.

It also requires a feeling for music. To entrust the gain control to a man without this feeling is like committing a \$1200 Sevres vase to a drunken chambermaid.

Some Facts About Coil Design

The Oscillating Circuit as a Form of Voltage Amplifier—The “Gain” in the Broadcast Spectrum of Some Typical Coils—The Essentials for a Well-Designed Coil

By ROSS GUNN

THE oscillating circuit, as applied to radio reception, has been so thoroughly discussed in the past that it might appear the matter has been completely exhausted. A certain point of view is always most fruitful in the consideration of oscillating circuits, especially in giving one a thorough understanding of the physical phenomena that take place. In the first part of the present paper an approach to the problem is made from a particular angle, and it will be shown that an oscillating circuit is not only a device to select a given frequency but may also be considered as a type of amplifier. In the second part of the paper, the radio-frequency inductance and its relation to selectivity and gain in a tuned amplifier, considering the oscillating circuit, is discussed. Finally, the prime factors that should be considered to make up the ideal coil are given.

The resistance or “loss” in an oscillating circuit is made up of several components, and it is convenient to divide the circuit resistance into two parts, namely, the part due to coil resistance, and the part due to condenser resistance. Modern condensers are relatively efficient since they have resistances of only a fraction of an ohm at broadcast frequencies, while the ordinary coils have resistances of from 5 to 50 ohms. It is then obvious that, even if a manufacturer of good condensers would succeed in cutting the resistance of his condenser in half, the total circuit resistance would be but slightly affected since the condenser resistance is, in general, but a small percentage of the total circuit resistance. On the other hand, if the coil resistance were cut in half, the circuit resistance would be cut almost in half, and the signal impressed on the grid of the amplifier will be double what it would be with the original poor coil. An improvement of this magnitude would be well worth while, and may be accomplished by giving sufficient attention to the design of the coil used in the oscillating circuit. Attention is directed to the coil particularly, because the good modern condensers are so much better than the best coils that there is no particular gain made by the use of the highest grade condensers. The coil, then, should be the object of considerable attention and study until its losses are reduced to a minimum.

In the following discussion it is shown that an oscillating circuit may be considered as a type of voltage amplifier, and a physical interpretation of the relation of the circuit constants to the gain or desirability of any given circuit will be given. The physical interpretation that this method leads to, simplifies to a great extent the perplexing questions that arise, when one tries to state definitely just what is desired in an oscillating circuit.

Every electrical oscillating circuit consists of an inductance, capacity, and a resistance (with usually an oversupply of the latter). The inductance serves to store the energy in the form

of a magnetic field, the capacity serves to store the energy in the form of an electrostatic field, and the resistance serves to transform this stored energy into heat. The physical picture of what happens as the energy shifts from the condenser to the coil, and back again, is undoubtedly familiar to the reader, and will not be given at this time. In case the reader is unfamiliar with

ROSS GUNN, the author of this article, which is the first of two on the subject of receiving set inductors, was formerly a radio research engineer for the United States Air Service. Mr. Gunn is now attached to the Sloane Laboratory at Yale University and has devoted considerable attention to the problems involved in the design and use of coils in high-frequency oscillating circuits. The present article does not pretend to be revolutionary, for the basic theory involved is at least 50 years old. The author, instead of discussing power factor and decrement, which have little meaning to many readers, has chosen to use a factor which has a simple physical interpretation. The idea that there are two potentials in an oscillating circuit and that their ratio is the power factor, is of course well known, but the use of the factor “G” to explain the best ratio of inductance to capacity, has rarely been pointed out. The casual reader will find this story an excellent discussion of circuit problems which are by no means abstract, and those who are better informed should be interested in the work Mr. Gunn and his assistants have done, and in the way in which it is presented.—THE EDITOR.

this process, he is referred to almost any good elementary textbook on physics or electricity.

When the theory of oscillating circuits is examined, it is found that, in any series resonant circuit, there may be considered to be two high-frequency potentials which are approximately 90 degrees out of phase with each other. That is,

when one potential reaches its instantaneous maximum, the other potential is going through its instantaneous zero value. These two potentials have a certain interesting relation in terms of the circuit constants. One of these potentials will be referred to as the *applied* potential and the other as the *generated* potential. The applied potential is the potential introduced into the circuit from some outside influence, such as an oscillator or an antenna. This applied potential is in phase with the high-frequency current flowing in the oscillating circuit. The other potential, or the generated potential, is produced within the circuit, by the action of the oscillating current, and is 90 degrees out of phase with the current and the applied potential.

The current flowing in any alternating current circuit is determined by the applied potential and the circuit constants, in the manner given by the well known equation:

$$I = \frac{E_a}{\sqrt{R^2 + \left(2\pi fL - \frac{1}{2\pi fC}\right)^2}} \quad (1)$$

where I is the current, E_a is the applied potential, L is the inductance, C the capacity, R the equivalent series resistance, f the frequency, and π is a numerical constant of value 3.1416. If the circuit is resonated to a definite frequency, the reactances are balanced and equation (1) reduces to:

$$I = \frac{E_a}{R} \quad (2)$$

where I , E_a , and R are the same as previously mentioned. The greatest interest, however, is not in the current flowing, but in the signal produced by the applied potential. Considering now the application of the oscillating circuit to a radio set, it is assumed to be connected to a vacuum tube as shown in Fig. 1, and so neutralized that there is no appreciable regeneration. Since the vacuum tube is a device controlled solely by potential, the greater the potential we are able to apply to the grid, the greater will be the output signal from the tube.

THE “GAIN” OF A COIL

THE diagram of connections in Fig. 1 shows that the condenser and the inductance are in parallel across the grid and filament of the amplifying tube. Therefore, any potential that appears across the inductance or condenser will be impressed on the grid of the tube. It is well known that, when an alternating current flows through an inductance, there is generated a potential which is determined by the following equation:

$$E_g = 2\pi fLI \quad (3)$$

where E_g is the potential generated across the coil, I is the current in the coil, L the inductance, and f the frequency. Similarly, the potential generated across the condenser is given by:

$$E_g = \frac{1}{2\pi fC} I \quad (4)$$

where the symbols are as before.

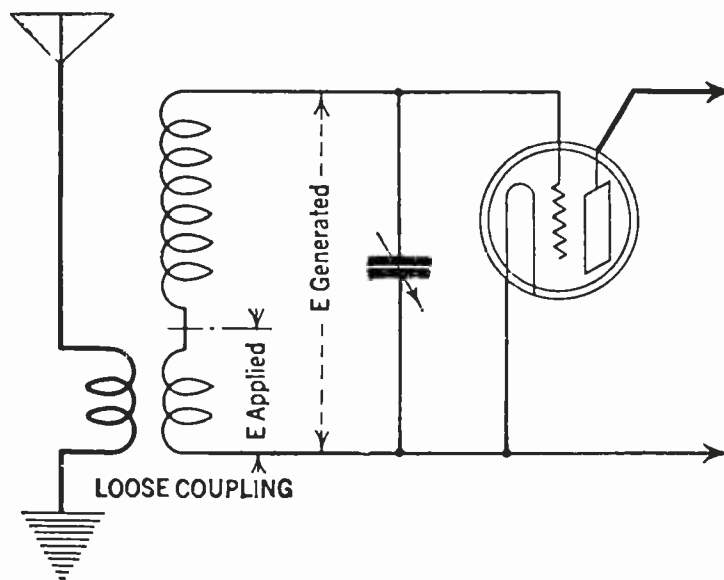

FIG. 1

If we eliminate the unknown current from the equations (3) and (4) by substituting the relation expressed in (2), we obtain the following results:

$$\frac{E_g}{E_a} = \frac{2\pi fL}{R} = \frac{1}{2\pi fCR} = \frac{1}{R} \sqrt{\frac{L}{C}} = G \quad (5)$$

or rewriting in the more convenient form, we have, due to inductance:

$$E_g = \frac{(2\pi fL)}{R} E_a \quad (6)$$

or:

$$E_g = \left(\frac{1}{R} \sqrt{\frac{L}{C}} \right) E_a \quad (7)$$

or simply:

$$E_g = G E_a \quad (8)$$

where G is either of the factors given above and always has a value greater than unity. That is, the potential applied to the grid of the amplifier tube is always greater than the applied potential by a factor " G ". The factor " G " is therefore of the nature of an amplifying factor, and the writer has usually referred to it as the "circuit voltage amplifying factor."

It has been suggested that this factor be called the "gain" and since this is a much more convenient term, we shall now call " G " the gain due to the oscillating circuit. Obviously then, the factor " G ," or the gain, should be made as large as possible for any given circuit. To illustrate this idea, suppose we had two oscillating circuits, one with a value for " G " of 50 and the other a value of 200. Suppose further, that there was such an antenna current and such coupling in both cases that the applied potential was $\frac{1}{50}$ of a volt. Then since $E_g = G \times E_a$, the potential applied to the grid of the tube (that is the generated potential) would be $50 \times \frac{1}{50} = 1$ volt in the first case and $200 \times \frac{1}{50} = 4$ volts in the second case. Obviously then, the coil with a high value of " G " would be the best. It may then be said, that in an oscillating circuit, the potential impressed on the grid of an associated tube depends on the potential applied to the oscillating circuit, and depends equally on a gain factor " G ," which in turn is dependent for its value on the circuit constants only.

Before considering the application of the above results to the determination of the proper coil, it will be valuable to point out the intimate relation between this factor " G " and other characteristics of the oscillating circuit. Consider first, the relation between the factor " G " and the selectivity of the circuit. The selectivity, or the "sharpness of resonance," of an oscillating circuit is directly proportional to the factor " G ," and if we define selectivity or sharpness of resonance as the ratio of the natural frequency of the tuned circuit at resonance to the difference of the natural frequencies of the circuit when on each side of resonance, such that the oscillating energy on each side of resonance is just one half the energy at resonance, then the selectivity so defined is exactly equal to the factor " G " or:

$$\text{Selectivity} = \frac{f_r}{f_2 - f_1} = G \quad (9)$$

where f_r is the natural frequency of the oscillating circuit when in resonance with the incoming wave, f_2 the natural frequency of the tuned circuit at a point above resonance, such that the oscillating current is 70.7 per cent. of the current at resonance, and f_1 is the natural frequency of the tuned circuit at a point below resonance, such that the oscillating current is 70.7 per cent. of the current at resonance.

This definition is equivalent in every way to

the usual one. The fact that the selectivity of a circuit and the gain go hand in hand is indeed a very pleasant one since, if one increases, the other automatically increases also.

THE EFFICIENCY

THE expression for the efficiency of an oscillating circuit may be easily obtained by defining the efficiency in the following manner:

$$\text{Efficiency} = \frac{\text{ENERGY OBTAINED PER HALF CYCLE}}{\text{ENERGY SUPPLIED PER HALF CYCLE}}$$

This for convenience may be written as:

$$\text{Efficiency} = \frac{\text{ENERGY SUPPLIED} - \text{ENERGY LOST}}{\text{ENERGY SUPPLIED}}$$

Now, the energy supplied per half cycle is the maximum energy stored in the inductance which is given by the well known equation:

$$\text{Energy} = \frac{L I^2 \text{max.}}{2}$$

where L is the inductance and I max. is the maximum current. Moreover, the energy lost per half cycle is:

$$\frac{R I^2}{2f}$$

where R is the equivalent series resistance, I is the root mean square current, and f is the frequency. Making use of the relation between root mean square current and maximum current, namely:

$$I^2 = \frac{I^2 \text{max.}}{2}$$

the efficiency may be written as follows:

$$\text{Efficiency} = \frac{\frac{L I^2 \text{max.}}{2} - \frac{R I^2 \text{max.}}{4f}}{\frac{L I^2 \text{max.}}{2}} = \frac{L - \frac{R}{2f}}{L}$$

and canceling out the common factors, the efficiency reduces to:

$$\text{Efficiency} = 1 - \frac{R}{2fL} = 1 - \frac{\pi}{G} \text{ since } G = \frac{2\pi fL}{R}$$

or

$$\text{Efficiency} = \frac{G - \pi}{G} = \frac{G - 3.1416}{G}$$

or for per cent. efficiency:

$$= \left(\frac{G - 3.1416}{G} \right) 100\%$$

Thus, if the gain is known for any given circuit, the efficiency may readily be computed.

This equation gives the efficiency of the circuit in the strict engineering sense and should not be construed loosely as a measure of the general performance of a coil. The poorest coils and condensers yield efficiencies of 90 per cent. and better while the best coils show efficiencies of 99 per cent., an apparent increase of but 9 per cent. The increase in performance would, however, amount to approximately 1300 per cent. for the good coil in comparison to the poor one.

Other things must be considered in radio telephony besides the intensity of the received signal. The quality of the received signal is of great importance and if we should increase " G " indefinitely we would soon have a circuit that would be so selective that the only frequency that would be amplified would be the carrier frequency, and the side bands, which give rise to the speech or music, would be cut off or, at the least, badly mutilated. There is an upper limit to the value of the "gain" if the quality of the speech is to be maintained. In the case of telegraphy, the upper limit is much higher than for telephony.

Calculations which would be tiresome and out of place in a discussion of this type, show that if all voice frequencies are to be faithfully reproduced up to 4000 cycles at a mean wavelength of 450 meters (666 kc.) the value of the factor " G " should not materially exceed a value of 250. This puts a definite upper limit to the gain or selectivity that can be used in the ordinary radio set.

Up to this point the discussion relates to the non-regenerative oscillating circuit as a whole. Now if the condenser used with the inductance is a good one, having a low resistance, then the losses of the condenser may, in comparison with the losses of the coil, be neglected. With this assumption, which is perfectly legitimate in the average case, we may then talk about the "gain" due to the coil, and understand by this, that this is the gain that would be obtained if the coil were used with any condenser of negligible resistance. These conditions have been met with in all experimental data given in this article since a precision condenser was used which was insulated with amber and which had a resistance of not over 0.2 ohm at 1000 cycles. Thus, at 300 meters (1000 kc.), the resistance would be entirely negligible.

Considering how the application of the principles just discussed are applied to an inductance, we may say that the inductance for any given circuit should be so chosen that the factor " G ," which, as we have shown, is a measure of the selectivity and the gain, should be as large as possible, provided it does not greatly exceed the limiting value for good quality.

Returning now to the factors that determine how large the "gain" will be in any case, equation (5) shows how this factor varies with the inductance, associated capacity, resistance, and the frequency. It is impossible to examine the equation and say off hand that the ratio of the inductance to the capacity should be very large, as equation (7) would seem to indicate, because, as the inductance of the coil is increased, the resistance increases, perhaps very rapidly, depending on the physical structure of the coil. On the other hand, if the capacity of the condenser is increased the circuit resistance will decrease, but at a relatively slow rate. It would then appear that in order to determine just what combination of inductance and capacity to use or to determine what types of coils are the best, it will be necessary to make measurements of this factor " G " and determine experimentally its values under different circumstances.

The factor for the "gain" may be determined in several different ways. The ratio of the generated potential to the applied potential may be measured directly by means of a vacuum-tube voltmeter, and since by definition this ratio is the "gain," we have a simple method of getting its value for different coils. The factor may also be determined by use of the definition for selectivity as given in equation (9) which can be transformed so that known condenser settings may be used instead of frequencies. The values for " G " in this paper were computed from the known values of the resistance, inductance, and frequency, since these data were already available in some cases from previous work.

SOME COIL EXPERIMENTS

A GREAT many measurements on different types of coils have been made during the last year in an attempt to obtain sufficient information to point the way to the design of still better types of coils. Curves showing the "gain" of various representative coils are included in this paper. In every case but one, the coils were

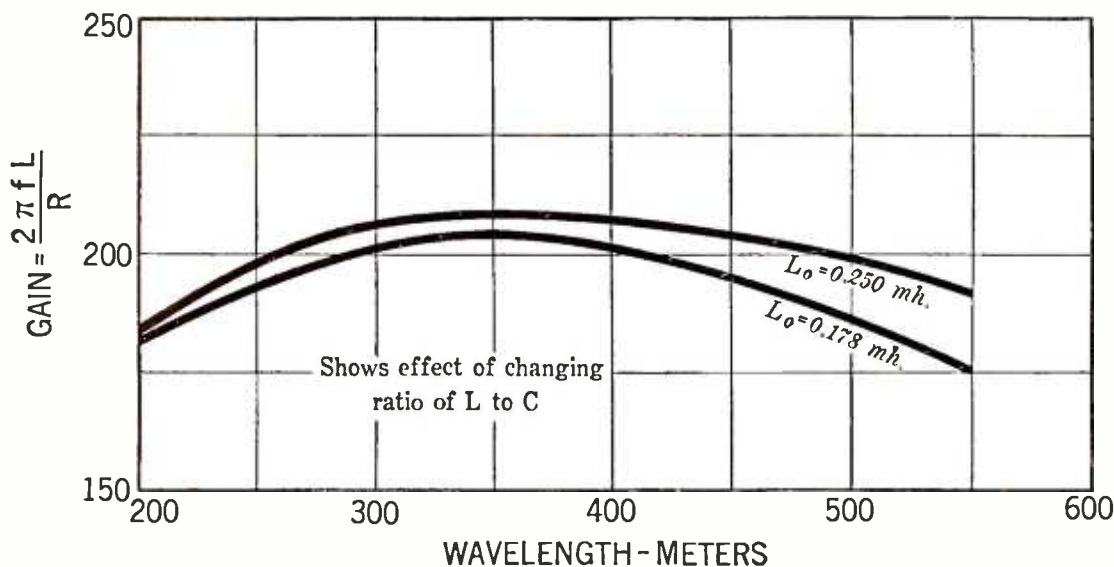

FIG. 2

purchased on the open market, and may be taken as reasonably representative of the commercial coils now available.

One of the first things investigated, in the light of the previous discussion, was the effect of changing the ratio of inductance to capacity in any circuit using coils of nearly identical construction. A single-layer solenoid, consisting of 45 turns of No. 24 s. c. c. wire was wound on a cardboard form of $3\frac{1}{8}$ inches in diameter. The values for the gain of this coil over the broadcast range, using a condenser with maximum capacity of 350 mmfd., were plotted as shown in Fig. 2, labeled $L_0 = 0.250$ mh. Wire was then taken off this coil until the coil resonated to 550 meters (545 kc.) with a maximum capacity of 485 mmfd. The values for the gain were again determined over the broadcast band and plotted as shown in the curve Fig. 2, labeled $L_0 = 0.178$ mh. These curves, with others, seem to show that the gain in any given oscillating circuit does not change greatly with moderate changes in the ratio of inductance to capacity. There does, however, seem to be some *slight* advantage in using the higher values of inductance.

Fig. 3 shows the value for the gain for a certain commercial "figure eight" coil. It was wound in the conventional manner, the winding beginning at one end and progressing in a series of "figure eights" to the other end. The coil was made up of 80 complete loops of No. 26 s. s. c. wire and had an inductance of 0.250 mh approximately. The coil was $1\frac{3}{8}$ inches long and $1\frac{1}{2}$ by 4 inches in the other directions. The gain for this type of coil was surprisingly low, as it varied from 100 to 130, as shown by the curve.

The curve for a typical commercial type coil is shown in Fig. 3 (b). This coil was a single-layer open solenoid of 0.245 mh. It was made up of 58 turns of No. 23 s. s. c. wire closely wound so it could be made self supporting with the aid of a binder. It was $3\frac{1}{8}$ inches in diameter and $1\frac{3}{8}$ inches long. The curve shows that the coil is not what one would call a bad coil.

Recent work of the Bureau of Standards has shown that in general the best type of solenoid construction is the type known as the "loose basketweave." The curve, Fig. 3 (c), shows the gain for such a coil. It was wound with 53 turns of No. 24 s. c. c. wire, and was $3\frac{1}{2}$ inches in diameter. This coil is a very good coil and would give the best of results if it is not placed too close to other apparatus.

Much better coils can, of course, be built by

the use of litzendraht wire, but the writer has only considered the solid wire-wound coil so far. A graduate student getting his Master's degree at Yale in 1926 succeeded in building a solenoid out of "litz" with which he obtained an average value for the gain of over 450 for the entire broadcast band. Such coils are, of course, exceptional and are more or less laboratory curiosities because of their size and large external field. They cannot be used in the vicinity of other apparatus without increasing the losses and hence decreasing the value for the "gain." This is because their field sets up either eddy currents in the metal parts, or causes dielectric losses in insulators. These losses naturally decrease the value of the gain.

THE IDEAL COIL

THIS brings up consideration of the ideal coil or high-frequency inductance. Considerable thought has been given to this question and

those points considered the most important, or necessary, are tabulated below. The requirements in their order of importance follow:

(a) The "gain" of the coil as previously defined, and hence also, its selectivity, should in general, be made as large as possible but should not exceed the limit of 250 for good quality.

This item in itself says a great deal, implicitly, since in order for the gain factor to be even as large as 200, say, all known methods to keep the coil losses down must be employed. This would mean, in general, that the coil would be self supporting, it would be wound with relatively small wire since small wire serves to keep the eddy current losses down, and it would be so wound that individual turns were reasonably well separated. It seems to have been pretty definitely established that the best coil is obtained when the wire is spaced by an amount about equal to the wire diameter. It would mean a great many other smaller things which can all be grouped under the statement given in the preceding paragraph.

(b) The exterior field of the coil should be zero or, certainly, very small. This is essential in order that there shall be as little stray energy exchange within the various circuits of the radio receiver as possible. Putting an ordinary coil having an exterior field in a metal can is to be discouraged, since it will greatly reduce the value for the "gain." For the same reason, the gain of an ordinary coil may be greatly reduced by mounting the coil in the vicinity of metal or poor dielectric.

(c) The distributed capacity of the coil should be very low, and the high- and low-potential ends of the coil should be well separated. The terminals of the coil should be well separated so that connecting wires to the coil will not introduce an excessive amount of distributed capacity into the circuit.

(d) Mechanically the coil should be strong and able to withstand a reasonable amount of abuse.

(e) Its physical structure should not be excessively large taking into account item (a).

(f) A commercial coil should have some marking which would give its "gain" over the broadcast band.

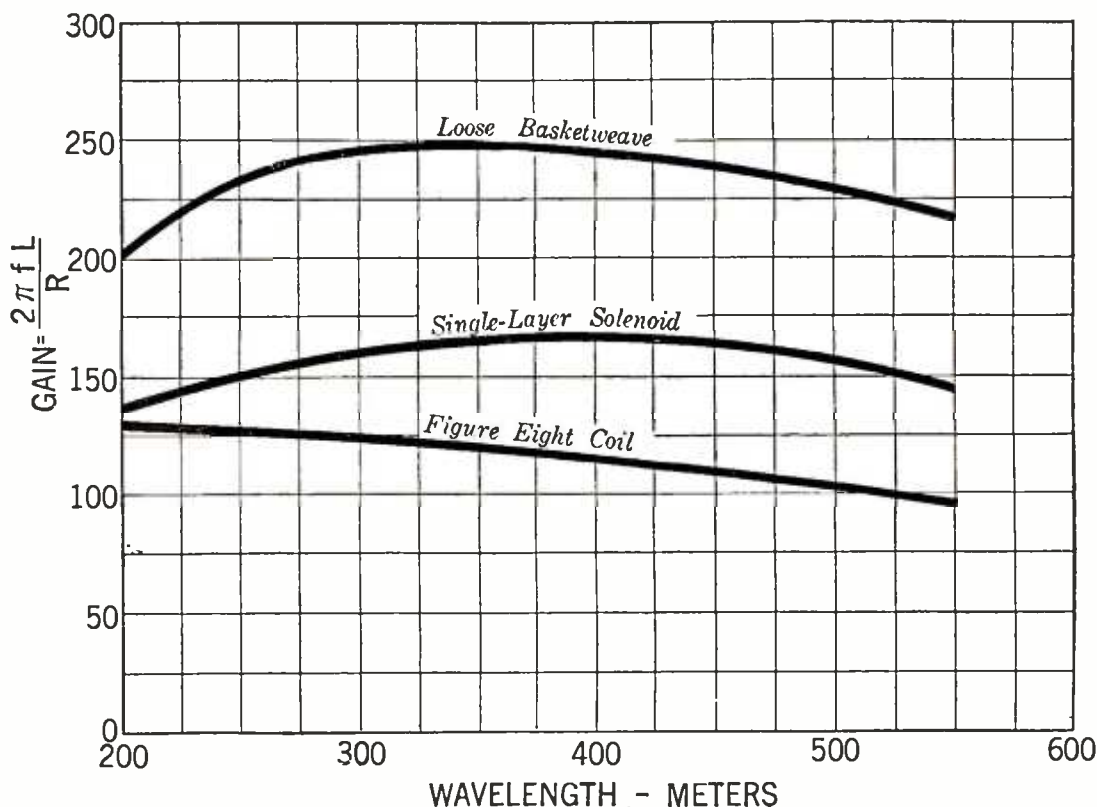

FIG. 3

Perfecting the B Socket Power Device

How the Oscillograph Is Utilized to Obtain Visual Indication of the Voltage Characteristics at Different Points of the Circuit—The Construction of a Better B Device with Uniform Output Properties

By HOWARD E. RHODES

B SOCKET power units are now in their second or third year of popularity, and during this time many excellent units have been designed. Some of the first models were described in this magazine as far back as September, 1924, but it was not until the present gaseous and thermionic type rectifiers became available that B power from the light socket became really practical for home use. It is surprising that since these rectifiers first became available there have been no important advances in design over the first models.

Power supply units are simple devices, employing principles that have been known many years, although their special application to radio is comparatively recent. Many construction articles have appeared in the various magazines but in these articles there has been little or no information as to how the devices function. It will be worth while to devote some space to a brief explanation of the fundamentals underlying the operation of any ordinary power unit.

For the purposes of our description we will use the power unit illustrated and described in this article. Sufficient information will be given to enable anyone to construct the unit and it is hoped that many will do so because this particular device gives very good results and has several design features, explained in this article, to particularly commend it.

B socket power units are devices intended to take power from an ordinary 110-volt 60-cycle a. c. house lighting system and convert it into high-voltage direct current suitable for the operation of a radio receiver. In order to accomplish this it is first of all necessary to transform the 110-volt a. c. power into energy of the same type but of higher voltage. This is accomplished by means of a transformer, a device which merely consists of two coils of wire wound on an iron core. If these two windings have a turn ratio of 1 to 2, placing 110 volts across the smaller, or primary winding, would give 220 volts across the other, or secondary winding; with a 1 to 3 ratio transformer the voltage across the secondary would be 330, and so on.

What does this voltage look like? We cannot see it directly, but with the aid of an instrument called the oscillograph, we are able to obtain a visual picture of it. The oscillograph consists of a thin wire, or vibrator, strung between two strong permanent magnets. A light is thrown on this wire and the shadow of the wire, by means of revolving mirrors, is thrown on a screen. If a current is passed through the wire, the magnetic lines of force set up by the magnets will react with the current variations through the wire, causing the latter to vibrate in

accordance with these current variations, and the way in which it vibrates will therefore indicate the character of the current flowing through it. It is possible to connect an oscillograph at various points in a circuit and in this way determine the nature of the current—whether it is alternating or direct, or whether it is a combination of the two.

In analyzing the a. c. line voltage at the input of the power device, the oscillograph, indicated by the circle with an "X" in it in Fig. 1, was connected across the primary of the transformer of the B power unit, as shown at "A," and at "B" is a copy of the picture that was seen. The line marked "zero" indicates the position of the vibrator when there is no voltage applied. The voltage starts at zero, rises to a maximum in one direction, decreases to zero, and rises to a maximum in the opposite direction, decreases to zero, and then starts the same cycle over again. The voltage across the secondary of the transformer has the same form but it is larger.

Across the secondary of the transformer we have a high a. c. voltage and the next thing to do is to change it to d. c. In the particular unit we are working with, this is accomplished with a CX-313 double-wave rectifier tube. This rectifier has two plates and two paralleled filaments so that both the halves of the wave—above and below the zero line in "B"—can be utilized. The CX-313 tube was arranged as shown at "C" in Fig. 1, only one of the plates being connected, and the oscillograph was connected as indicated. We now get a wave as shown in Fig. 1 at "D." Notice that we get a current through the circuit for each positive half of the a. c. voltage but nothing during the negative half, because the rectifier will only conduct current when the plate is positive, while during the half cycle when the plate is negative, no conduction occurs. If we connect

the other plate, as shown in "E," we will be able to take advantage of each half wave because, during the half cycle when terminal No. 5 of the transformer is negative, terminal No. 7 is positive, and thus, during the half cycle when no conduction is taking place from terminal No. 5, there will be current flowing at terminal No. 7. Consequently, we get a wave form in the oscillograph as shown in diagram "F" of Fig. 1. Now, for each half cycle of the original a. c. voltage shown in "B," we get a corresponding impulse in the oscillograph. But because of the rectifying action of the tube, which will conduct current only one way, all the impulses shown in "F" are in the same direction. We now have a circuit in which the current flows in only one direction, and this is the essential characteristic of a direct current. But, although the current is unidirectional, it is pulsating; that is, it goes from zero to its maximum value and then drops to zero again, and then repeats the same thing over again. Such direct current is not suitable for application to radio purposes for it must be perfectly constant for this use.

THE FILTER CIRCUIT

THIS brings us to the third part of a B power unit—the filter. In Fig. 1, at "G," we have added a filter to the output of the rectifier. The filter consists of choke coils L_1 and L_2 and condensers C_1 , C_2 , and C_3 . The function of the choke coils is to block any sudden changes in current while the function of the condensers is to act as storage tanks or reservoirs. Energy is delivered to the filter in the form shown in "F" and the filter serves to smooth out these impulses and to allow non fluctuating direct current to be drawn from its output. The oscillograph was first connected at X_1 , and the curve obtained is shown at "H." Here we notice a great change.

The ripple is not nearly as great as in the preceding picture and it never goes down to the zero line. Through the ripple we show a dotted line indicating the average value of the ripple current. What the curve means is that we now have a direct current, I_{ac} , with a small a. c. ripple in it, I_{ac} . The ripple must be gotten rid of so we pass the output through another filter section. The oscillograph drawing "I" was obtained by connecting the instrument in the circuit at the point marked X_2 in "G". Notice how much smaller the ripple is. The filtration is almost complete. Connecting the oscillograph on the other side of the last filter condenser, C_3 , at the point marked X_3 , we obtain the drawing shown at "J," and the ripple is entirely absent. This means that the voltage at the end of the filter is satisfactory to apply to a receiver.

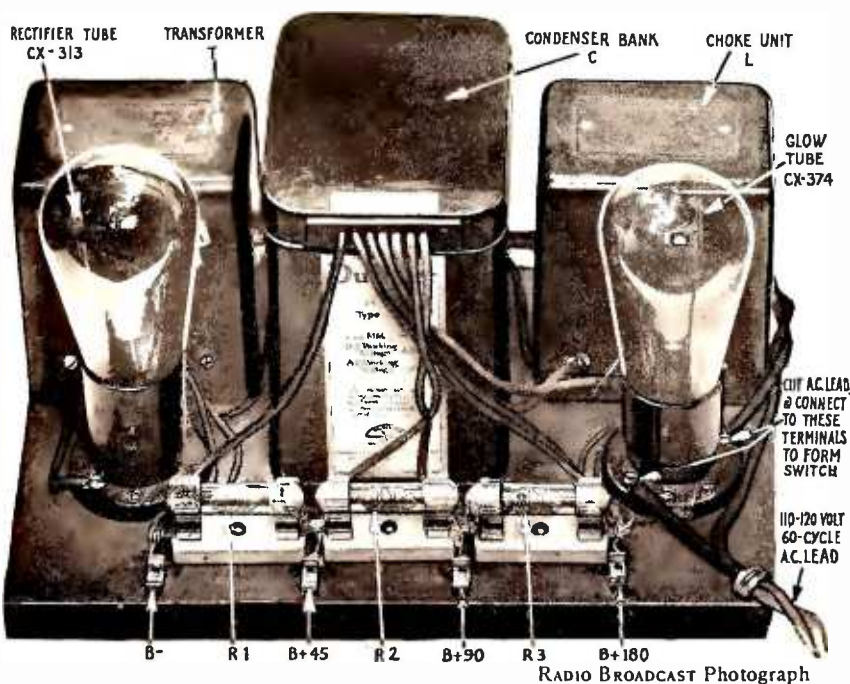

THE B DEVICE DESCRIBED IN THE TEXT

The filter is one of the most important parts of a B socket power device, and it is essential that it be carefully designed if it is to give best operation. The best filter will, of course, be that one which gives the least hum in the output consistent with reasonable cost. It is preferable to accomplish the filtration with a filter as small as is feasible because, in this way, it is possible to keep the resistance of the filter circuit at a low value. In "F" the filter is supplied with energy at the rate of 120 cycles per second. It therefore seems logical to design the first section of the filter to eliminate this 120-cycle ripple and to then use one additional filter stage to eliminate any other harmonic frequencies or any residual ripple that gets through the first section. A selective filter of this type has been patented by Kendall Clough and is used in the Silver-Marshall 331 Unichoke and also is incorporated in this unit because, with such a circuit, excellent filtering action can be obtained and, at the same time, it is possible to keep the filter resistance down to a fairly low value.

At the output of the filter we obtain the maximum voltage delivered by the device. A receiver, however, requires several different potentials for its operation. In most cases a high-voltage tap, say about 180 for a 171 power tube, a 90-volt tap for the first audio amplifier and the r. f. stages, and a 45-volt tap for the detector, are required.

To obtain the various voltages it is necessary to equip the device with an output potentiometer, which merely consists of a resistance, or several resistances, connected in series across the output, as will be seen in drawing "G," Fig. 1. This circuit diagram is similar to many power units in use to-day. It has one important disadvantage, which is that the voltage obtained from the various terminals depends upon the load. If one tube is supplied from the tap marked 90-volts it might really receive 110 volts, two tubes 90 volts, and three tubes only 70 volts, and so on. This is one important respect in which a B power unit differs from a dry battery. From a battery we obtain the same voltage at all reasonable loads, but from an ordinary power unit we obtain voltages that depend on the milli-ampere drain.

"MOTOR BOATING" CAUSES

THAT the output of most B power units varies with load is important because it is very likely that one of the causes of "motor-boating" is to be found in this fact.

"Motor-boating" is seldom experienced (although it is not an impossibility) when an amplifier is operated from good new B batteries. Ordinary B batteries must be discarded as the voltage runs down, the actual reason for this being that the internal resistance of a battery goes up as the voltage goes down, with the result that the high resistance, being common to the circuits of all the tubes in a receiver, may cause oscillation, and most certainly distortion. Considering a B power supply from this angle, we find a comparatively high internal resistance unavoidable with standard rectifying devices, and we further find a comparatively high resistance is necessary for the mechanical construction of satisfactory filter chokes. The net result is poor voltage regulation; that is, as the current drawn from the B supply increases, the voltage does not remain constant as with a battery but, instead, falls off at a fairly rapid rate. Curve A, Fig. 3, indicates the regulation that may be expected from a standard B supply with an extremely low-resistance filter. The higher the filter choke resistance, the poorer the voltage regulation; and, likewise, the higher the internal

resistance of the rectifier, the poorer the voltage regulation. In the case of batteries in good condition, the internal resistance being very low, the voltage remains substantially constant under normal current loads and a regulation curve for a battery is substantially a straight line. In itself, a falling characteristic may not, at first, appear to be a disadvantage so long as the curve indicates that the device is capable of supplying sufficient voltage at the particular load at which it is to be used, but, a poor regulation curve, indicating a high internal resistance, is doubtlessly an important contributory cause of "motor-boating" in a receiver.

"Motor-boating" can also be produced by overloading, which causes a change in the average plate current drawn by the receiver. If the average current drawn by the receiver varies,

the B power unit will be called upon to supply a varying load. If its regulation curve is not flat, any variation in the milliampere load will cause a change in the voltage supplied to the receiver and this will produce another surge in the receiver again affecting the average plate current and repeating the process. "Motor-boating" due to this cause will be prevented if the regulation curve of the power unit be made substantially flat, and this has been accomplished in the particular unit illustrated on page 43 by connecting into the output circuit a glow tube, as shown in Fig. 2. The problem of eliminating "motorboating" is complicated and for this reason RADIO BROADCAST Laboratory expects to make a series of tests in an endeavor to determine the exact causes of the trouble. These data will be published in a later article.

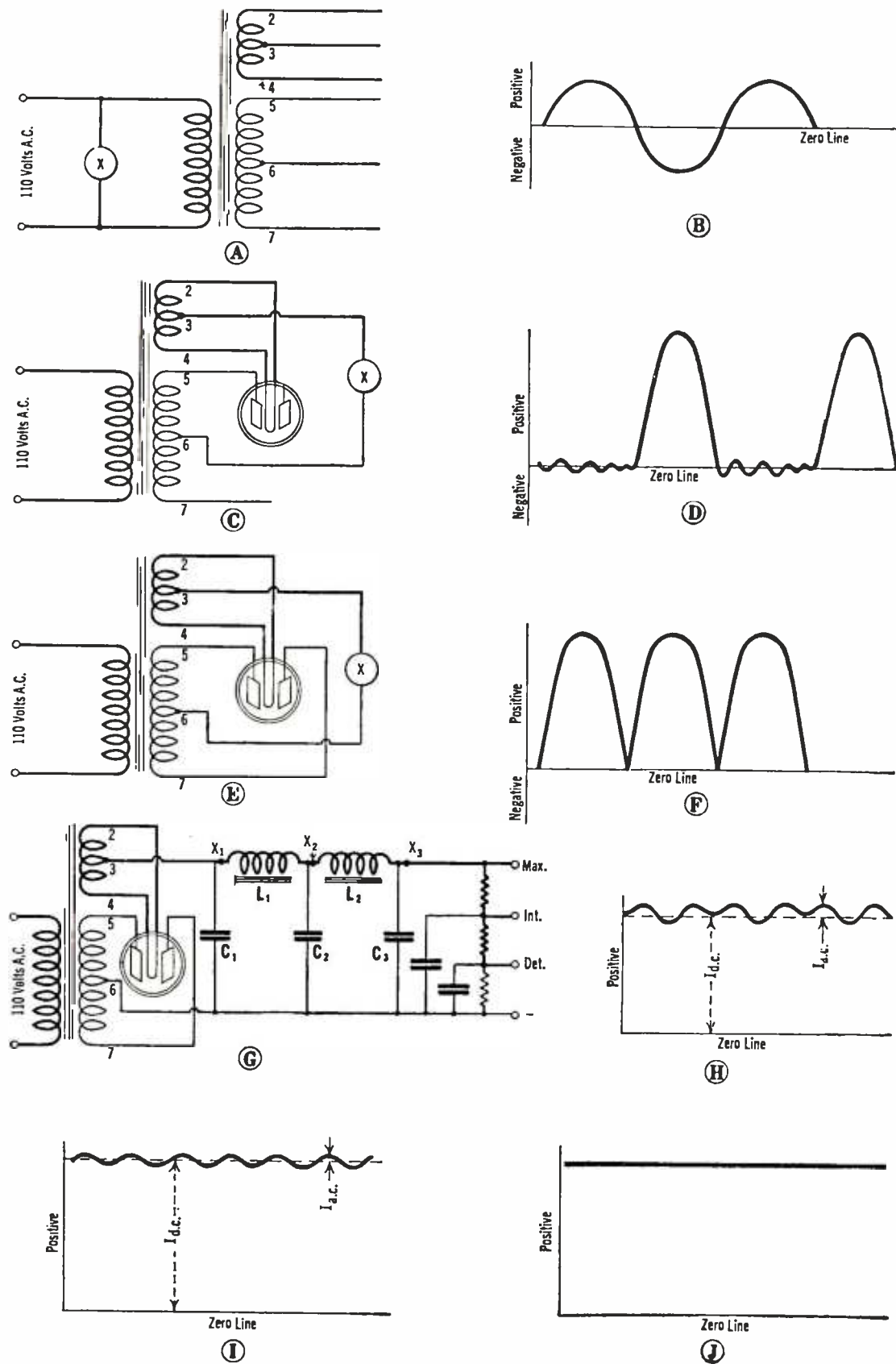
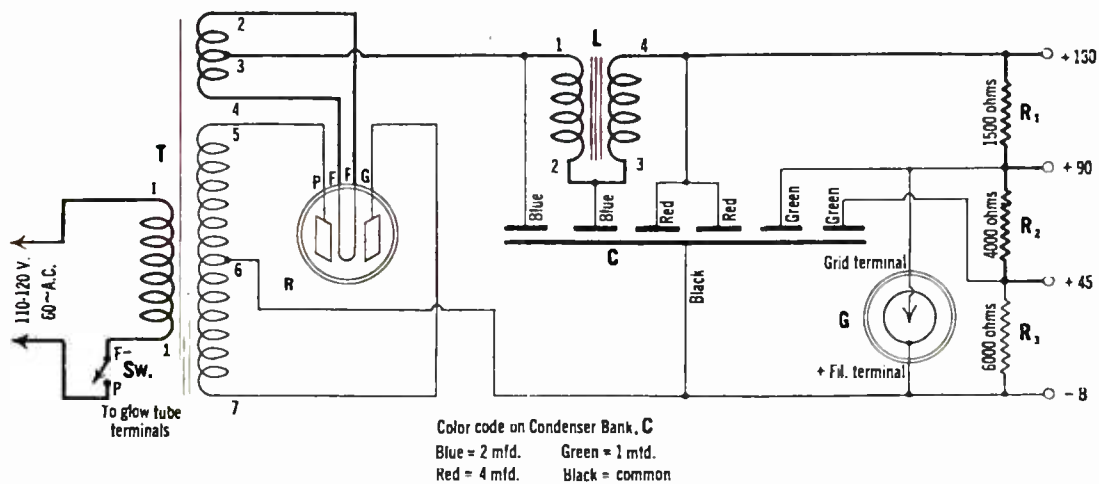

FIG. 1



Color code on Condenser Bank, C
 Blue = 2 mfd. Green = 1 mfd.
 Red = 4 mfd. Black = common

FIG. 2

The use of a glow tube to improve the regulation of a socket power device is a comparatively recent development. The effectiveness of this tube can be readily seen by referring to the curves B, C, and D in Fig. 3, and noticing that the voltage at the 90-volt tap varies only 5 volts between a load of 0 milliamperes to 45 milliamperes. The tube also affects the regulation of the other voltage taps on the device so that all of the taps show a comparatively small variation voltage with change in load. The voltage regulation at the 90-volt tap is most important since this tap generally supplies a majority of the tubes in a receiver. The use of a glow tube with the concomitant improvement in the regulation curve will eliminate a factor (poor regulation) which certainly has a very definite tendency to cause "motor-boating," and it is suggested that, where possible, the tube be used in conjunction with any B power unit that is causing a great deal of trouble.

As was mentioned at a previous point in this article, an important feature of the socket power unit illustrated herein is that it may be connected to any standard receiver drawing normal current with the certainty that the voltages will fall within the practically required operating limits, by virtue of the fact that a glow tube is employed. In an ordinary B unit, variable high resistances are used to control the output voltage, and it is seldom that the user has any definite idea what voltages are being applied to his receiver.

The parts necessary to build a B socket power employing the principles outlined in this article, are listed below:

LIST OF PARTS

R—Cunningham CX-313 Rectifier Tube	\$ 5.00
G—Cunningham CX-374 Glow Tube	5.50
T—S-M 329 Power Transformer, with 5-volt balanced filament winding, two 200-volt secondaries, and electrostatic shield	0.00
L—S-M 331 Unichoke	8.00
C—Dubilier Type PL 381 Condenser Bank	14.00
Two S-M 511 Tube Sockets	1.00
R ₁ —Amsco 1500-Ohm Resistor with Mounts—50MA. Type 125	2.00
R ₂ —Amsco 4000-Ohm Resistor—10MA. Capacity	.90
R ₃ —Amsco 6000-Ohm Resistor—10MA. Capacity	.90
Two Amsco Resistor Mounts	.30
Four Fahnestock Clips	.08
7" x 10" Wood Base with 17 No. 6, 1/2", R. H., wood screws, and 15 feet of Kellogg fabric insulated hook-up wire	.50
TOTAL	\$47.18

The parts mentioned in the above list were used in the model constructed in the Laboratory and are known to give good results. There is no reason why the parts of other manufacturers might not be substituted provided care is taken to make certain that the electrical characteristics of the substituted parts are equivalent.

The Amsco type 125 resistance was not used in the model made up and illustrated in the photograph on page 43. It will be found that the type 125 unit is one inch longer than the resistance shown in the photograph.

Satisfactory block condensers are also made by Silver-Marshall, Tobe Deutschmann, Aerovox, Sangamo, Muter, Faradon, and the resistors that are used may be the products of any reputable manufacturer provided they are capable of carrying the currents that are specified. The S-M 653 resistor (Ward Leonard S 11500), costing \$2.50, can be used in place of the Amsco resistors and mounts.

The construction of the unit is very simple. Upon the 7" by 10" wood base, beginning at the left-hand rear, the power transformer is screwed down with the Dubilier condenser bank along side of it, and the Unichoke at the right-hand end. The socket for the type 313 tube is placed directly in front of the transformer, while that for the 374 glow tube is placed directly in front of the Unichoke. The three resistance mounts are lined up in front of the sockets, and then, in front of the resistance mounts, are placed four Fahnestock clips. The left-hand clip is negative, and progressing to the right, we have the plus 45-, plus 90-, and plus 180-volt taps. Wiring to most of the units can be done without soldering, if desired, by simply fastening the scraped ends of the connecting wire under the terminal screws of those units which are so equipped. The circuit diagram given in Fig. 2 is marked with terminal numbers which correspond to those on the parts that were used in this particular model, and this will aid in making it a simple matter to correctly wire the

entire unit. No particular care is necessary in the way in which the wires are run since there is little danger of feed-back. Just run the wires in the most convenient way to the various terminals. By reference to the circuit diagram it will be noted that a switch, marked Sw., is indicated in the primary of the power transformer. This switch is part of the glow tube base. The terminals in the glow tube corresponding to the plate and minus A (minus A as indicated on the Silver-Marshall socket) are short-circuited inside of the tube base wiring. Therefore, the lead from the unit that connects to the 110 volts a. c. is cut and one end connected to the plate terminal of the glow tube socket (right-hand socket) and the other end connected to the negative filament terminal of this same socket. With this connection, the power is thereby automatically cut off if the glow tube is pulled out of its socket. This is necessary because, with the glow tube removed, there will be practically 180 volts at the 90-volt tap.

In operation, there are practically no precautions to be observed; the unit is foolproof. The four B-battery leads from the receiver are simply connected to the similarly marked posts on the B unit, the receiver and B unit turned on, and reception obtained by tuning the receiver in the usual fashion. The 175 volts at 20 milliamperes, obtainable from the 180-volt tap, will operate a UX-171 type tube to perfection. The 90-volt tap will supply up to 45 mils. at this voltage; the 45-volt tap up to 10 mils., as shown by Fig. 3. There is no danger of damaging tubes and condensers in the receiver due to high-voltage surges from the B unit, since the voltage of the high tap can never rise above 190 volts.

In use, the two lighted filaments of the CX-313 rectifier tube will cause the tube to get rather warm; at no time should the plates ever become red due to heating. The glow tube will glow with a bluish or pinkish light, and this may possibly flicker when a very strong signal is being received, due to the reciprocating action of the tube. If too great current—more than 45 milliamperes—is drawn from the 90-volt tap of the unit, the glow tube may cease to glow. Turning off the receiver will immediately result in this tube re-lighting, after which the set may again be turned on. If more than 45 milliamperes is drawn by the 90-volt receiver circuit, it should be examined for trouble. The brilliancy of the glow in the CX-374 regulator tube will vary with different loads.

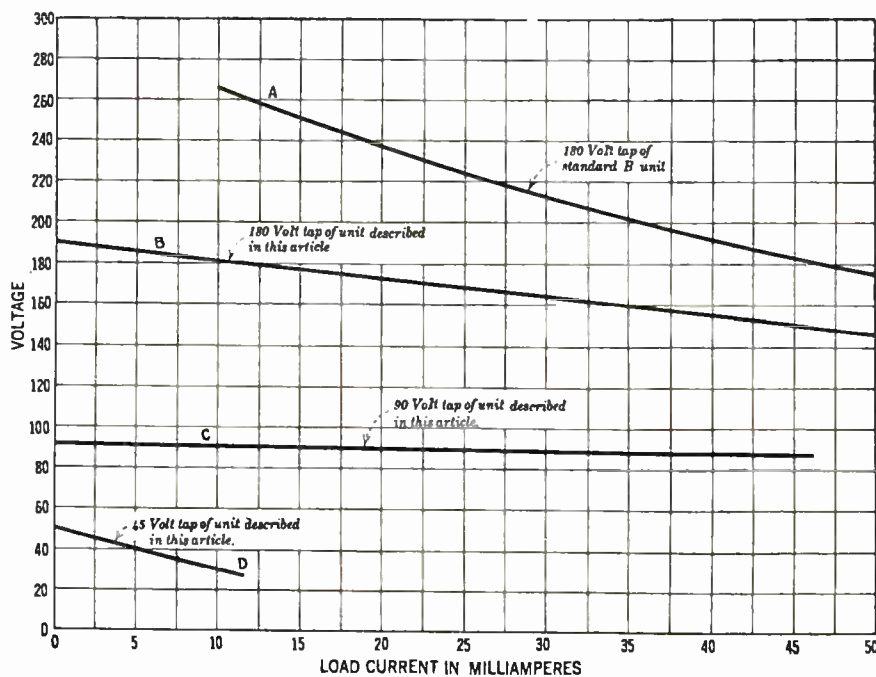

FIG. 3

Methods of Measuring Tube Characteristics



A Paper Delivered Before the Radio Club of America Discussing the Several Bridge and D. C. Systems for Use in Obtaining Tube Characteristics



By KEITH HENNEY

Director, Radio Broadcast Laboratory

IT IS neither the desire nor purpose of the writer to burden this article with an eulogy on the vacuum tube. Nearly every article that has appeared on the tube in the popular radio press has done that, pointing out that it is a most wonderful device, the modern Aladdin's Lamp, and a number of other superlatives that fill up space. There can be no doubt that the tube is important. Witness our present broadcasting structure, our long-distance telephone service, our communication by telephone across the Atlantic, and by high frequencies and exceedingly low powers to all parts of the world. All of these things depend upon the tube.

No study of the tube can be complete without a knowledge of its varied services. For example, it is possible with a tube to convert direct current from a set of batteries to alternating current of all frequencies from as near zero as one likes up to 60,000 or more kilocycles. It is then possible, with another tube exactly similar to the first, to convert these extremely high frequencies back to direct current. It is also possible to amplify both direct and alternating currents, and hence amplify power. It is also possible to separate what is placed on the input of the tube into direct and alternating currents of practically any ratio desired. All of these varied functions are carried out without any moving parts, without noise, with practically no loss of power, and with so little fuss that tubes now exist that are capable of giving service for 20,000 hours, a life greater than that of the circuit in which they are used. There can be no doubt about the importance of the tube in the field of electrical engineering. In addition, tubes and their associated circuits are now being used to measure the rate of growth of plants, to measure extremely small differences of thickness, the strength and rapidity of a man's pulse, and from this latter, to determine whether he is a lover, a thief, a liar. The tube has been harnessed and trained to do a vast number of interesting tricks.

Now this little assembly of glass and metal performs its multitudinous functions with the aid of three elements. The first and most important of these elements is the filament. This filament has undergone rather remarkable changes since tubes first came into existence. The first ones were made of tungsten which operated with a high temperature, then going to low temperature oxide-coated filaments manufactured by a complicated and difficult process, thence to our most recent filament, the thoriated wire. The measure of efficiency of the filament is its emission per watt expended in heating it, and the newest thoriated wire is exceedingly efficient. Pure tungsten filaments operate at a very high temperature. Oxide filaments consume considerable current at low voltage and at a much lower temperature. Thoriated filaments are somewhere between.

The other two elements are the grid and plate, and because these elements can be changed in

size and relative position, tubes differ in characteristics. There must, then, be some means by which engineers can compare tubes just as they rate generators and motors or other electrical apparatus.

TUBE CONSTANTS

IN TUBE engineering, there are two very important factors which, when known, define the tube in exactly the same manner that we used to say in school that the United States is bounded on the north by Canada, on the east by the Atlantic Ocean, etc. The two constants—which really are not constants at all—are the amplification factor and the plate impedance,

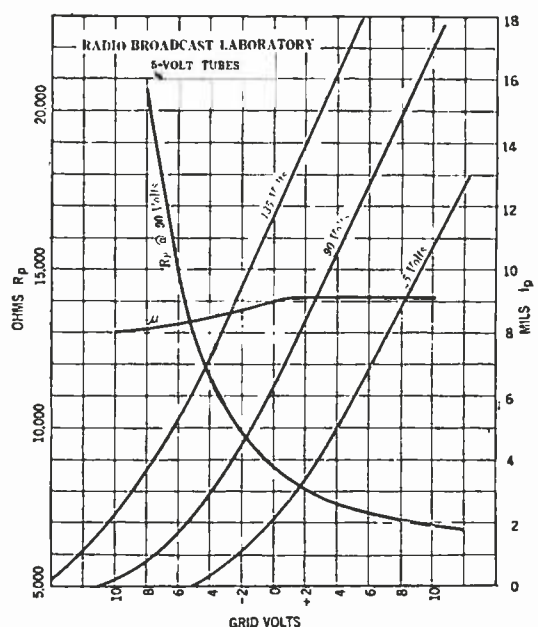

FIG. 1

and every function that the tube performs and its efficiency in doing so may be discovered by a knowledge of these factors and the constants of the circuits into which the tube works.

Another factor is the mutual conductance which, contrary to popular opinion, is not so important as it may seem. The term is somewhat difficult to picture physically. It has the dimensions of a conductance, *i.e.*, a current divided by a voltage, but the current exists in one circuit and the voltage in another, with the tube as the connecting link. It is due to Professor Hazeltine.

These constants, or factors, are variable within rather wide limits. For example, the amplification factor may range from 3 to 30, while the impedance varies, as someone has said, from Hell to Peru. The amplification factor is pretty well determined when the tube is sealed and pumped; that is, it depends on within very narrow limits upon the geometry of the tube. The mesh of the grid and its spacing with respect to the other elements are the governing

factors. At low grid voltages the amplification factor falls off somewhat, rising to a maximum at zero grid voltage, and remaining constant thereafter, or falling gently in some tubes.

The plate impedance depends upon a lot of things, the filament efficiency, the amplification constant, and the grid and plate voltages. No one curve or graph can show how it varies. To properly represent it would require a three-dimensional model, such as has been constructed by Doctor Chaffee and others. Some photographs of very beautiful models of this nature may be seen in the *Proceedings of the I. R. E.*

After the tube is sealed and placed in operation the impedance changes with each change in instantaneous plate or grid voltage—all of which makes the theory of the tube more or less complicated.

These three elements, the filament, the grid, and the plate, cause any current flowing in the plate circuit to change, making it go through very wide fluctuations. The plate current is defined by the equation:

$$I_p = f(E_p + \mu E_g)$$

By maintaining constant any one of the three variables in this equation and varying the other two, we arrive at the relation between the plate current and the voltage on the grid or plate that we usually know as characteristic curves, and it is by means of these curves that the important tube factors are defined. For example, both grid and plate potential have some effect on the grid voltage, but the grid is relatively more important than the plate. In Fig. 1 it may be seen that at zero grid bias, changing the plate voltage from 90 to 135 changes the plate current by 5.2 milliamperes, while changing the grid bias by 5 volts will do the same thing.

The amplification factor is then defined as the ratio of the change in plate potential to the change in grid potential which produces the same effect in plate current. In this case the amplification factor is 9:

$$\mu = \frac{\Delta E_p}{\Delta E_g} = \frac{135-90}{5-0} = \frac{45}{5} = 9$$

The other factor of importance, the plate impedance, is the ratio between the change in plate voltage to the resultant change in plate current. In this case it is 45 volts divided by 0.0052 amperes, or roughly 8700 ohms:

$$R_p = \frac{\Delta E_p}{\Delta I_p} = \frac{135-90}{0.0116-0.0064} = \frac{45}{0.0052} = 8700$$

Now, as has been indicated by the Greek letter Δ in the definitions, these factors are defined by changes, and for accuracy the changes must be small.

The mutual conductance, defined as the ratio between a change in plate current and the change in grid voltage that produced it, is also the ratio between the amplification factor and the plate impedance, as can be seen from the mathematics below. For comparing tubes under exactly the same conditions, this factor is somewhat import-

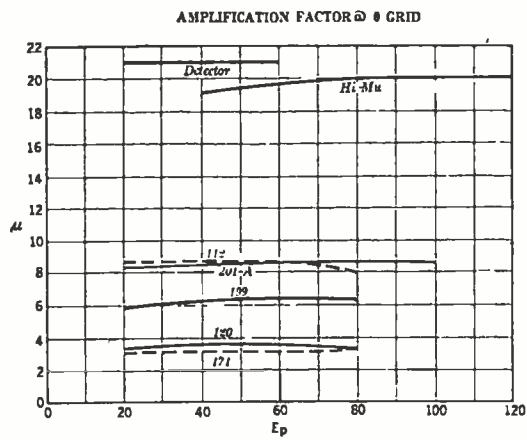

FIG. 2

ant, but as will be shown later, it serves little purpose in telling an engineer how well such a tube will function in the circuit:

$$G_m = \frac{\Delta I_p}{\Delta E_g} = \frac{\mu}{R_p} = \frac{\Delta E_p}{\Delta E_g} + \frac{\Delta E_p}{\Delta I_p}$$

Figs. 2, 3, and 4 show how the tube factors change. The fact that the plate impedance is the reciprocal of the slope of the E_p-I_p curve is shown in Fig. 4. When the plate-current curve straightens out, the R_p curve is parallel to the E_p axis, but finally rises again as the saturation point is reached. These data were taken on a rather poor 199 tube.

It is a simple matter to get the tube factors from a set of characteristic curves which may show the effect upon the plate current of the grid or plate voltage. It is somewhat tedious, however, to take a mass of data and to plot it and then to pick off points on the resulting curves to determine the tube's factors. In actual practice it is simpler to go through a little routine, say of measuring the plate current under certain conditions of plate and grid voltage and then to get a new current by changing the grid voltage. This gives the mutual conductance. Then the plate voltage can be changed to get the plate impedance, and to multiply these factors together to get the amplification factor. At the risk of too much repetition the writer wishes to emphasize here that changes in grid and plate voltage must be small if the resultant determinations of amplification factor and plate impedance are to be representative of the tube's characteristics.

MEASURING THE TUBE CONSTANTS

THE various bridge methods of measuring tubes were developed to provide quick and simple means of measuring tubes.

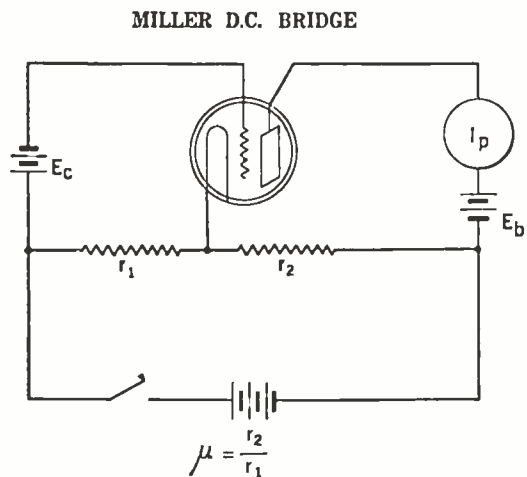

FIG. 5

One of the first methods of making quick measurements was due to J. M. Miller, and is shown in Fig. 5. In practice, the resistances, r_1 and r_2 , are varied until closing the switch causes no change in plate current. Under these conditions the amplification factor is given by the ratio of r_2 and r_1 . This follows from a consideration of the law governing the plate current as a function of grid and plate voltages given above.

If, with the switch closed, the voltage across plate and filament is increased, the corresponding grid-filament voltage is decreased. If no change in plate current takes place, however, the following relation holds:

whence
$$\frac{(\Delta E_p + \mu \Delta E_g)}{r_2 + \mu r_1} = 0$$

and
$$\mu = \frac{r_2}{r_1}$$

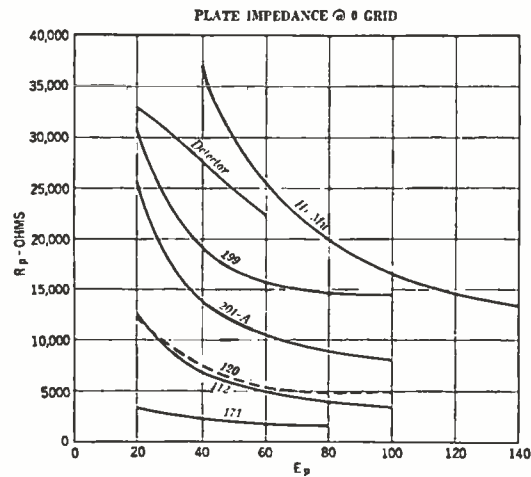

FIG. 3

LABORATORY BRIDGE

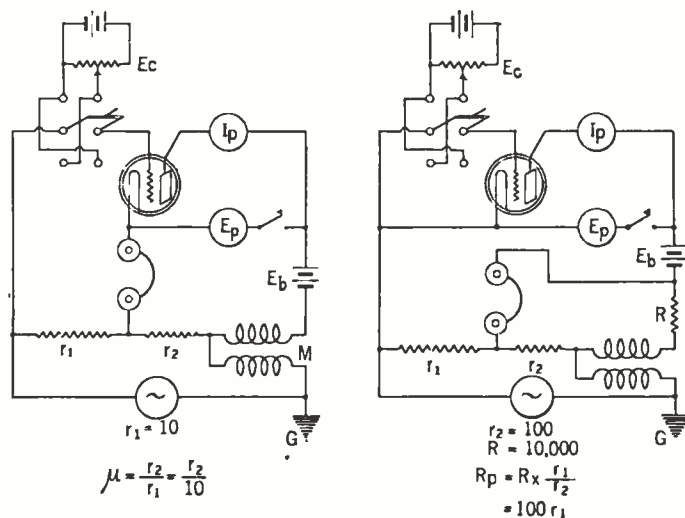

FIG. 7

The first improvement on this simple bridge was to substitute a.c. voltages in place of the plate ammeter. Under these conditions the amplification factor is found in exactly the same manner. When the bridge is balanced, indicated by silence in the receivers, the amplification factor is the ratio indicated above.

Miller described also the simple addition to this scheme which permits measurements of the plate impedance to be made as shown in Fig. 6. It is not difficult to prove that the bridge balance indicates that the following relation holds:

$$R_p = R \left(\mu \frac{r_1}{r_2} - 1 \right)$$

There is one disadvantage in this system. It is necessary to measure the amplification factor before the other factor may be obtained. Since

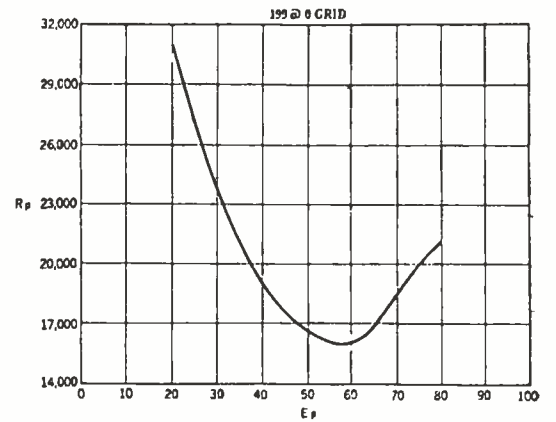

FIG. 4

the amplification factor is a constant over the ordinary ranges of grid and plate voltages, one determination will suffice for a given tube. It must be remembered, however, that any error in measuring μ will cause an error in R_p .

In the RADIO BROADCAST Laboratory a bridge has been in use for several years which will measure either the μ or plate impedance, independently of each other, and has the additional advantage that the desired factors may be read directly. This bridge in its two forms, which are easily convertible to each other, is shown in Fig. 7. The method of obtaining the amplification factor is exactly that of the Miller bridge while the other constant is measured in another arrangement of the same parts used by Miller.

In all of these bridges it is necessary to use some amplification to indicate a balance unless the work is done in a quiet room. The amplifier should preferably use batteries separate from those used for the bridge. The source of tone may be a buzzer a hummer, or an oscillator. As a matter of fact, a radio receiver might easily be used, since there is practically no change in tube characteristics at audio frequencies. The inclusion of a small variometer in the plate circuit to balance out the quadrature of plate voltage due to the grid-plate capacity, is also useful. Care must be taken with regard to the way it is connected into the circuit so that it will not be necessary to take into account its reactance in the final calculation of tube factors. When connected correctly the reactance, which is never greater than 10 or 15 ohms, is in series with the plate impedance. In the other connection this reactance is in series with the balancing resistance and will give absurd results.

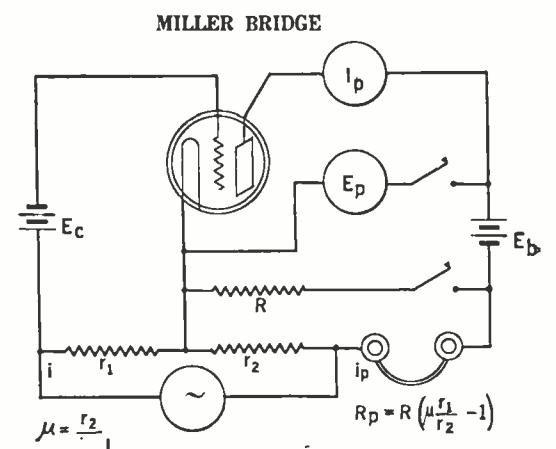

FIG. 6

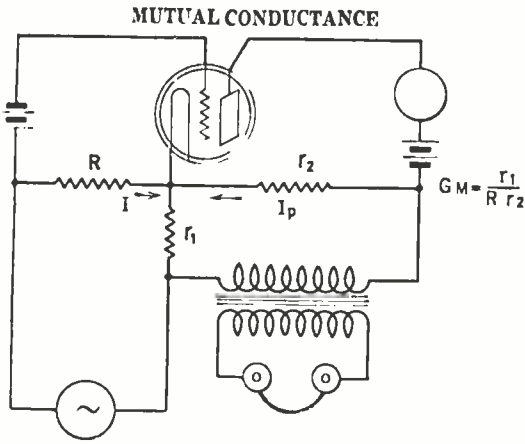

FIG. 8

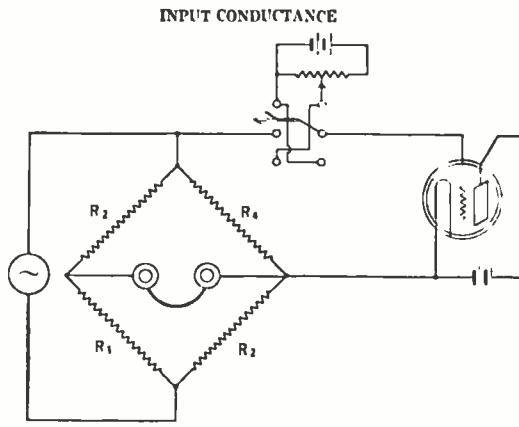

FIG. 9

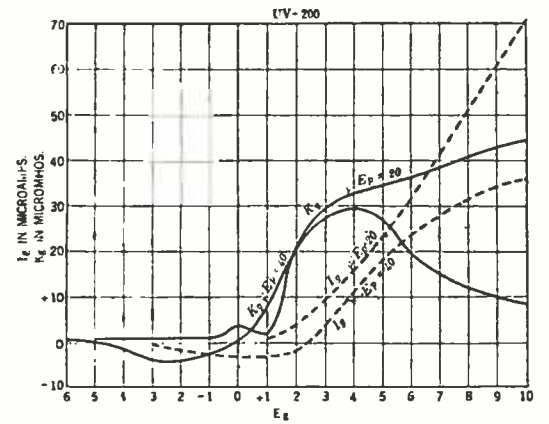

FIG. 10

There are two sources of error in the bridges shown so far. One is in the drop in plate voltage due to the plate current flowing through the balancing resistance. The other is the resistance drop of the indicating device, whether this be a pair of receivers or the primary of a transformer. Trouble from this source may be avoided by making certain that the actual plate-filament voltage is of the value desired after the balance is obtained, and by the use of a low-resistance transformer, such as a modulation transformer, to connect the bridge with the associated audio amplifier. On the Laboratory bridge, a push button connects the plate voltmeter when its reading is desired. Otherwise it is out of the circuit.

In practice, the normal filament, grid, and plate potentials are applied to the tube, and a 1000-cycle current of about one to two milliamperes flows through the bridge arms. To obtain a balance in measuring mu, the resistance in the grid circuit is set at 10 ohms and the plate resistance and variometer varied for balance. Thus, a tube whose mu is 8 requires 80 ohms in the plate side. In a quiet room, and with leads from the oscillator well separated from the amplifier mu can be read to the second decimal place. When tubes of high amplification factor, say 20 to 30, are measured, it is well to reduce the input grid resistance so that a smaller resistance is placed in the plate circuit.

To measure plate impedance with the Miller bridge, the switch is closed and a new balance obtained, when the factor desired is obtained as a function of mu. In both this bridge and in the Laboratory bridge, the resistance, R, against which the tube impedance is compared, may be fixed exactly at 10,000 ohms, although the value is not important as long as it is definitely known. On the Laboratory bridge the plate resistance is set at 100 ohms and the grid resistance varied for balance. If the impedance is 12,000 ohms, Rg will be 120.

MUTUAL CONDUCTANCE BRIDGE

There are a number of other bridge schemes for measuring the various factors in which engineers are interested. Ballantine has described several in the *Proceedings of the I. R. E.* One of these is a method of measuring the mutual conductance directly, and for comparing a great many tubes of the same sort under the same

conditions, it provides a useful instrument for the laboratory or tube manufacturer, or even dealer. This is shown in Fig. 8. It will be seen that it differs but little from the other arrangements.

Another set-up of apparatus will measure the input characteristics of the tube at low frequencies. It is shown in Fig. 9. At balance, the grid conductance (the inverse of the input impedance) is given by:

$$K_g = \frac{R_1}{R_2 R_3}$$

and in practice, with normal tubes, all balancing is done with R1, since R2 is held constant at 100 ohms, and R3 at 10,000 ohms. With soft tubes the conductance may change sign at high plate potentials, and it is then necessary to give the input a positive conductance by actually connecting across the grid and filament a high resistance, say of 50,000 ohms. The tube conductance may be obtained by subtracting from this known value, that determined by the bridge. Data given in Fig. 10 on a soft tube show the effect of ionization in giving the input circuit a negative conductance.

COMMERCIAL TUBE TESTERS

There are a number of tube testers on the market some of which are very expensive. As far as the writer knows, there is but one which measures tubes according to the bridge schemes outlined above. This is made by the General Radio Company and uses the Miller connections. Others are made by the Hickok Company of Cleveland, by Jewell, Hoyt, and others. The Hickok uses a 60-cycle voltage obtained from a step-down transformer. The others vary the grid and plate voltages by fixed—and it is to be hoped, small—amounts, and obtain the various factors either directly or by simple calculations. They are quite reliable and valuable instruments although not capable of the precision that a true bridge circuit can attain.

It is also possible to obtain tube constants from a knowledge of the d.c. resistance. For a given type of tube, the plate impedance at certain conditions of plate and grid voltage may be obtained by multiplying the d.c. resistance under those conditions by a constant factor; at some other value of plate and grid voltage it will be exactly equal to the d.c. resistance. For example, dividing the d.c. resistance of a 201-A type tube at 90 volts on the plate and a negative 4.5 bias on the grid by 2.7 will give an approximate idea of the a.c. impedance.

Table No. 1 is representative of what may be expected from such methods of estimating tube impedance.

A tube tester with a d.c. plate current meter calibrated with several scales will read the plate impedance with an accuracy that may be all that is desired by dealers and others who do not need to use the values in circuit calculations.

The factors of tubes commonly used to-day are shown in the accompanying tables, Figs. 11, 12, 13, and 14. It is a fact to be thankful for that tubes are now so uniform, since a tube with odd constants placed into a well-engineered receiver is often enough to change conditions from good to very bad. A year ago such standardization had not been reached, as data on file in the Laboratory show.

Now, having shown how various tube factors may be calculated from curves, or measured with bridges or d.c. instruments, it remains to be shown how useful such factors are, and in some measure to justify

TABLE NO. 1

Type	Ep	Eg	A.C. Rp	D.C. Res.	Factor	Where d.c. = a.c.
201-A	90	-4.5	11000	30000	2.7	Ep 90, Eg -2
190	90	-4.5	18500	37500	2.0	Ep 90, Eg -3
112	135	-9.0	5500	21400	3.0	Ep 135, Eg -0.6

200-A TUBES			
TUBE	NO. TESTED	AMPLIFICATION CONSTANT	PLATE IMPEDANCE
Perryman	2	37.5	31750
Cunningham	3	22.5	24000
Sylvania	2	20.8	25000
Cleartron	3	24.5	38000
Marathon	3	21.6	38000
Q.R.S.	3	21.0	31000
Cable Supply Co.	3	26.3	37200
Marathon	3	16.5	22000
Q.R.S.	3	22.5	25000
R.C.A.	2	21.0	26000
	Total 27	Average 23.4	29795

Conditions
February 8th, 1927
Plate Volts 45
Grid Volts 0

FIG. 11

the statement that mutual conductance is not the determining factor in a tube's goodness or unfitness for particular tasks.

In receivers, as we have them to-day, the first tube generally acts as a radio-frequency amplifier with inductance in both plate and grid circuits. It is necessary that the plate-grid capacity be small and that a given make and type of tube will be uniform. It is also necessary that the input impedance be high and the output impedance be low, for maximum gain. For example, the maximum possible gain from an amplifier is given by the well known expression:

$$K = \frac{\mu}{\sqrt{R_p}} \times \frac{\sqrt{R_g}}{2}$$

and a little mathematics will show that when the proper load is inserted into the plate circuit of a high-frequency amplifier that the maximum amplification will be given by the formula:

$$K_m = \frac{\frac{1}{2}\mu}{\sqrt{R_p}} \frac{L\omega}{\sqrt{R}}$$

where L is the inductance of the secondary coil and R the effective resistance of the circuit. Tube

CECo TYPE K				
No.	μ	R_p	G_m	μ^2/R_p
1	11.1	11,700	950	10.5
2	12.1	13,000	930	11.3
3	12.5	15,700	795	10.0
4	11.0	12,200	900	9.9
5	13.1	14,000	880	11.5
6	11.2	13,100	855	9.6
E _p =90			E _g =-3	

TABLE NO. 2

were measured. These data should be on the carton of every tube sold.

Table No. 2 is illustrative of the fact that the mutual conductance of a tube may be lower than another and still have a higher "gain" factor; e.g., compare No. 3 and No. 6 of this table.

DETECTOR IMPEDANCE

THERE has been much speculation about the output impedance of a detector tube. This is important in order that amplifier engineers know exactly under what conditions their

products will work. For example, it is well known that a transformer-coupled amplifier will have one characteristic working with a tube of 10,000 ohms and another out of 30,000 ohms. Just what is the average impedance of a detector?

It is somewhat difficult to picture what happens when we measure this impedance in one of our bridges. The detector is a distorting device and a pure thousand-cycle note used for balancing the bridge will no longer be a pure note in the output. Furthermore, a detector tube has both high- and low-frequency voltages in both input and output. What effect has this combination of frequencies upon its impedance, if any? Is the impedance of a C-battery detector the same as that of a grid leak and condenser with grid slightly positive? It seems reasonable that the C battery demodulator will have a much higher impedance which may cause us to sit and think when such a device is recommended because of the superior quality of reproduction possible by its use.

There are other problems. For example, shall we place the voltage directly on the grid; shall

112 TUBES				
TUBE	NO. TESTED	AMPLIFICATION CONSTANT	PLATE IMPEDANCE	MUTUAL CONDUCTANCE
Cunningham	3	8.3	4660	1785
Daven Mu 6	1	5.3	5150	1060
Diatron	1	6.5	4670	1400
Hercultron	1	9.0	8700	1035
Q.R.S.	1	6.5	5700	1140
Regal	1	9.0	7400	1215
Zetka	4	8.1	7550	1114
Total	12	Average 7.5	6260	1250

Conditions
 Plate Volts 135 Grid Volts -9
 February 8th, 1927

FIG. 12

171 TUBES				
TUBE	NO. TESTED	AMPLIFICATION CONSTANT	PLATE IMPEDANCE	MUTUAL CONDUCTANCE
Cunningham	2	2.9	2100	1380
Cleartron	3	2.6	2610	1000
Perryman	2	3.15	2650	1190
DeForest	2	2.5	2500	1000
Ureco Special	1	2.5	2000	1250
R.C.A.	5	2.85	2200	1300
Hercultron	1	3.25	2800	1160
Sylvania	2	2.7	2100	1290
Marathon	7	3.1	2600	1190
Total	25	Average 2.84	2395	1195

February 8th, 1927 Conditions
 Filament Volts 5 Plate Volts 135 Grid Volts 27

FIG. 13

constants enter into other circuit calculations as shown below:

$$\text{Voltage Amplification} = \frac{1}{2}\sqrt{R_i} \times \frac{\mu}{\sqrt{R_p}}$$

$$\text{Power Amplification} = \frac{R_i}{2} \times \frac{\mu^2}{R_p}$$

$$\text{Power Output} = \frac{E_g^2}{8} \times \frac{\mu^2}{R_p}$$

where R_i is the input resistance and E_g is the input volts, peak.

In every case it will be seen that the tube enters in some ratio of its amplification constant squared, divided by its plate impedance. Knowing this factor, it is only necessary to insert it into circuit equations and calculate the result at once.

There has been much talk among tube manufacturers regarding standardization, and a universal desire is evidenced for a single term by which tubes could be rated. Unfortunately, no such term has been provided simply because no mathematics has been invented that will make such a thing possible. The important factors are the plate impedance, the amplification factor, and the figures for grid and plate voltage under which the values

201-A TUBES				
TUBE	NO. TESTED	AMPLIFICATION CONSTANT	PLATE IMPEDANCE	MUTUAL CONDUCTANCE
Apco	5	6.3	8850	755
Armor	5	7.25	8360	850
Boehm	9	6.95	9030	780
Cable Supply Co.	8	7.4	9810	754
Ceco	6	8.15	11150	736
Champion	5	8.54	13320	643
Cleartron	17	7.1	10420	680
Cunningham	8	8.30	10825	750
DeForest DL 5	4	9.65	11100	885
DeForest DL 2	4	7.15	8625	830
DeForest DL 4	1	8.3	11200	740
Empiretron	3	7.1	10230	694
Fultone	6	8.85	11800	750
Gormac	5	7.15	12400	578
Hytron	3	9.43	14833	635
Ken-Rad	20	8.55	12450	695
Magnatron	2	8.0	12250	652
Marathon	9	8.2	11540	713
Perryman	14	7.6	10350	740
Q.R.S.	24	8.2	11440	715
Schickerling RS 10	3	7.93	10167	790
Sky Sweeper	8	7.84	13100	600
Sonatron	4	8.43	13350	632
Strongson	6	8.2	9300	885
Supertron	3	9.5	14600	680
Sylvania	11	8.36	11100	757
Televocall	5	7.1	8000	860
Ureco	15	7.2	9820	800
Van Horne	12	8.63	12800	677
Voltron	19	5.64	7000	845
Zetka	8	8.1	13100	620
Total	225	Average 7.9	10000	735

Conditions
 February 8th, 1927 Plate Volts 90 Grid Volts -4.5

FIG. 14

the plate circuit have a load other than the resistance; shall there be radio-frequency voltages in the circuit?

Several schemes have been suggested to determine whether bridge measurements on distorting tubes mean anything. The one described here is due to Mr. Howard Rhodes of the staff of RADIO BROADCAST Laboratory. It follows from the succeeding consideration. In Fig. 15 is the symbolic representation of a simple circuit in which R_p is the usual tube impedance, and R_o is some other resistance inserted into the circuit and whose value is variable and known. It is simple enough to measure the voltage across this resistance.

Let us suppose the tube impedance, R_p, is 5000 ohms and that we measure and plot the voltage across R_o as the latter is varied. When the two resistances are equal, E_o will be $\frac{1}{2}\mu E_g$ and when R_o is 3R_p, E_o will be $\frac{3}{4}\mu E_g$, or 1.5 times as much as when R_o and R_p are equal. We shall then get a curve similar to that of Fig. 15. From these data a triangle may be formed

whose base is fixed at three units and whose vertical leg is, when $R_p=R_o$, equal to 1.5. It is then only necessary to plot the voltages developed across known resistances in the plate circuit of the detector tube and to form the above triangle on this curve. Some data on detector impedance measured by several methods will be available later. Table No. 3 is the result of bridge methods.

POWER OUTPUT

THE final measurement in which we shall be interested at present is that of undistorted power output. With the advent of tubes of the 112, the 171, and the 201 class, honest-to-goodness amplifiers have been possible, and many strange misconceptions have arisen from a none too clear understanding of their nature. Some people think that a great increase in volume will result from the substitution of a 171 for a 201-A. Of course such a result is impossible. As a matter of fact the 201-A, with its larger mu, will produce twice as much voltage amplification as a 171, provided the proper impedances are used, but it is certain that more power, with less

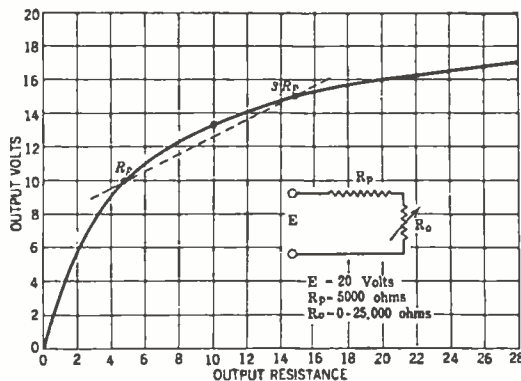

FIG. 15

Tube	E_g	E_p	R_p	R , megs.	C
201-A	-4.5	45	30,000		
201-A	G.L.	45	9500	1.5	0.00025
112	-4.5	45	14,000		
112	G.L.	45	6800	1.5	0.00025

TABLE NO. 3

where E_g is a peak voltage. If $R_o=2R_p$ this value becomes:

$$\frac{2\mu^2 E_g^2}{9R_p}$$

It is well known that the maximum power will be delivered to the loud speaker when the latter's impedance equals that of the tube, and recent data published in this country and in England indicate that the greatest amount of undistorted power will be delivered when the loud speaker impedance is twice that of the output tube. Fig. 17 shows how the power and the voltage gain of a tube vary with input voltage. When the lower bend of the characteristic curve is traversed, considerable rectification takes place, with corresponding change in d.c. plate current. When the plate current has changed roughly

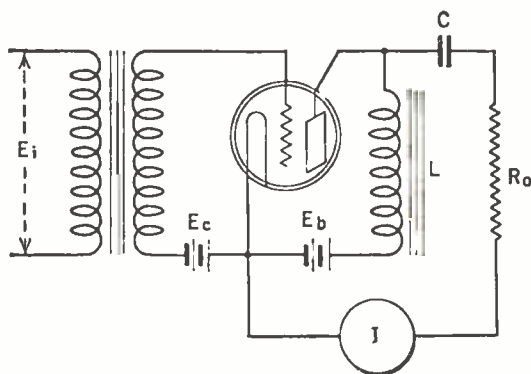

$$W_o = I^2 R_o$$

FIG. 16

distortion, will be delivered to the loud speaker when a true power tube is used.

In the first place it may be said that measurement of undistorted power output from present-day tubes seems impossible, for the simple fact that there is no such thing. The question is one of allowable distortion, which involves not only matters of opinion but the particular amplifier and loud speaker used.

It is simple enough to measure the power from a tube. It is only necessary to measure the current through a known resistance, and if the tube constants are known to within ten per cent., and if the grid does not take over 10 microamperes in 350,000 ohms, approximately, the measured power will check the mathematical value to within 10 per cent.

The power developed in the load resistance in Fig. 16 is:

$$\frac{\mu^2 E_g^2 R_o}{(R_o + R_p)^2}$$

And when $R_o=R_p$ this simplifies to:

$$\frac{\mu^2 E_g^2}{8 R_p}$$

10 per cent. the voltage amplification falls off, and the power output-voltage input curve flattens out.

Fig. 18 differs from Fig. 17 in several respects. Here the grid circuit is fed through a transformer. When the grid goes positive, the characteristic curve flattens out, duplicating roughly the curve at the lower bend. This results in smaller change in average d.c. plate current but a greater loss in amplification. In either case the change in plate current is a fair means of indicating distortion due to positive grid or to rectification at the lower bend.

NEW TUBES

TWO new tubes have been announced recently. One is a 300-milliamperere rectifier which will make it possible to run 201-A type tubes in series from rectified a.c., while the other follows a suggestion of Mr. B. F. Meissner, whose paper, delivered before the Radio Club of America paper, on lighting filaments from a.c., was printed in the February and March issues of RADIO BROADCAST. This new tube requires two amperes at

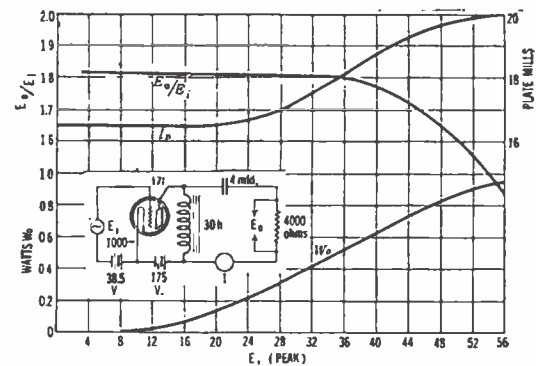

FIG. 17

0.6 volts. Naturally the voltage drop across such tubes to r.f. currents is remarkably low. Its thermal inertia is increased vastly over that of even 112 type tubes. The problem seems to be one of making a filament that will have a life comparable to that of other tubes now procurable.

It must be admitted that there are a great many tube measurements that have not been discussed in this brief paper. For example, there is much to be done with detectors; with the possibility of using amplifiers in which the grid takes considerable current; on the effect of the amplitude of input a.c. voltages upon tube factors; and a host of other interesting and important measurements. There is, at the present time, too much taking the tube for granted, not only by the hundreds of thousands of users, but by manufacturers and engineers as well. A tube is not merely a thing to shove into a radio receiver socket; it is a sensitive and delicate device with a patient and willing nature.

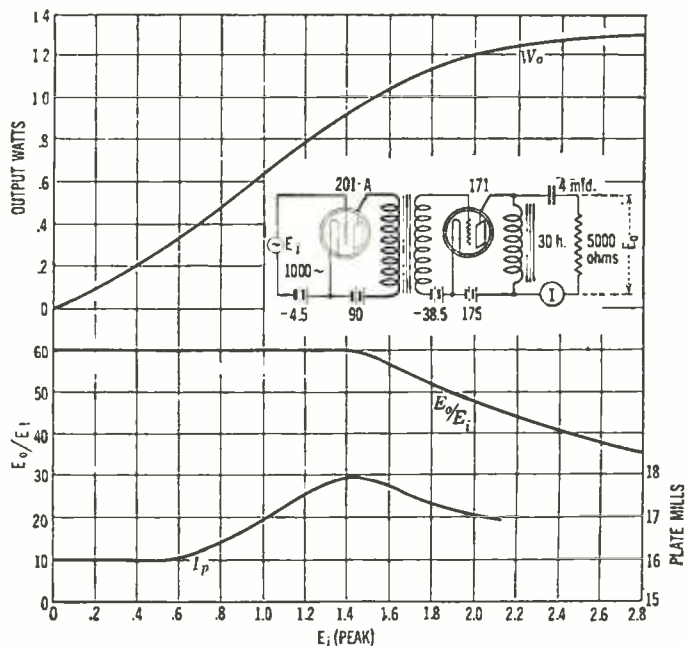

FIG. 18

RADIO BROADCAST is the official publication of the Radio Club of America, through whose courtesy, the foregoing paper has been printed here. RADIO BROADCAST does not, of course, assume responsibility for controversial statements made by authors of these papers. Other Radio Club papers will appear in subsequent numbers of this magazine

FUTURE PERFECTION OF RADIO RECEPTION DEMANDS RADIO TUBES DESIGNED FOR EACH RADIO FUNCTION.

deForest



Like the Benvenuto Cellini cup from the Altman collection of the Metropolitan Museum in New York, the De Forest Audions are fine examples of craftsmanship and painstaking skill.

DE FOREST engineers have recognized certain characteristics in the functioning of tubes in all radio units. Our laboratories have labored long to advance these characteristics that so improve radio reception, and now, these highly desirable elements have been developed in De Forest Audions for specific operations in the various radio reception departments.

Fans who are keen to bring their radios up to the highest degree of efficiency will eagerly adopt these Specialist Audions, the idea of which has long been appreciated in England.

These new De Forest Specialist Audions are now available for detector work, radio frequency amplification and use in all audio stages in types taking up to 500 volts on the plate.

To demonstrate the advantages of this idea and the improvement possible in your radio's performance tune in a weak and distant station

or turn down the volume of a local until you can just barely hear it in the loud speaker. Substitute De Forest DL-4 Specialist radio frequency Audions in place of the RF amplifiers you have been using. Note the remarkable increase in volume—how much louder the distant station and how the music of a local is raised to room filling proportion.

Radio amateurs will appreciate the characteristics of these efficient tubes. We must remember that regardless of RF circuits, tubes for best results must be uniform. The rigid limits, both electrical and mechanical, to which De Forest Audions are held assure a high standard of uniformity. With a very constant grid-plate capacity and high mutual conductance the volume these Audions obtain from distant reception is both amazing and satisfying.

These DL-4's are recommended for trial before you change *all* the tubes in your set.

De Forest Audions have been standard since 1906. The same genius who has made the broadcasting of voice and music possible is still hard at work for greater perfection and greater achievement in radio reception.

Of course, De Forest has designed a general purpose Audion. It is a good one and where price is a consideration the DOI-A Audion is an unequalled value at \$1.65. This tube is built to the same high standards of quality that mark all De Forest Audions.

De Forest dealers are pretty much everywhere. Look for displays of the brilliant black and orange Audion containers in shop windows. (Metal boxes in which De Forest Specialist Audions are packed insure their safety and dependability.)

If dealer is not available write for booklet which describes characteristics of each Audion and for chart indicating proper replacements for all standard makes of radio.

DE FOREST RADIO COMPANY

Powell Crosley, Jr.



President

JERSEY CITY, N. J.

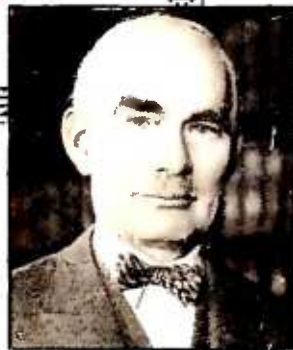



Dubilier condenser block TYPE: PL-381 as specified by RADIO BROADCAST

Type PL-381 condenser unit has been selected by Radio Broadcast because of its long life and general adaptability. It is the ideal eliminator condenser because of the improved dielectric material used. Each unit must withstand severe tests in order to pass our rigid inspection standards. Dubilier high quality workmanship and reputation protect your investment and eliminate trouble.

Note the Flexible, Rubber-Covered Leads and convenient mounting tabs. Metallic containers protect condenser element from moisture and mechanical injury.

Capacities 2,2,4,4,1, 1 mfd. operating voltage 400 D.C.



—and now
**DUBILIER
BUFFER
Condensers**

For satisfactory service using the Raytheon rectifier tube, the new Dubilier buffer condenser is absolutely essential. Made of two .1 mfd. condensers electrostatically shielded from each other and from external capacity effects. **Flexible rubber-covered leads.** Metallic containers with mounting tabs. Two types: PL-91 for 400 volts D.C.; PL-340 for 600 D.C. volts.

At all Dealers

Write For Booklet

(A new booklet "17 Ways to Improve your Set" will be mailed on receipt of ten cents. Tells how to use fixed condensers and gives circuit details. Be sure to get your copy.)

Dubilier

CONDENSER CORPORATION
4377 BRONX BLVD NEW YORK, N.Y.

The Radio Broadcast LABORATORY INFORMATION SHEETS

INQUIRIES sent to the Questions and Answers department of RADIO BROADCAST were at one time answered either by letter or in "The Grid." The latter department has been discontinued, and all questions addressed to our technical service department are now answered by mail. In place of "The Grid," appears this series of Laboratory Information Sheets. These sheets contain much the same type of information as formerly appeared in "The Grid," but we believe that the change in the method of presentation and the wider scope of the information in the sheets, will make this section of RADIO BROADCAST of much greater interest to our readers.

The Laboratory Information Sheets cover a wide range of information of value to the experimenter, and they are so arranged that they may be cut from the magazine and preserved for constant reference. We suggest that the series of Sheets appearing in each issue be cut out with a razor blade and pasted on 4" by 6" filing cards, or in a notebook. The cards should be arranged in numerical order. Several times during the year an index to all sheets previously printed will appear in this department. The first index appeared in November.

Those who wish to avail themselves of the service formerly supplied by "The Grid," are requested to send their questions to the Technical Information Service of the Laboratory, using the coupon which appears on page 60 of this issue. Some of the former issues of RADIO BROADCAST, in which appeared the first sets of Laboratory Sheets, may still be obtained from the Subscription Department of Doubleday, Page & Company at Garden City, New York.

No. 89

RADIO BROADCAST Laboratory Information Sheet

May, 1927

Short-Wave Coils

SOME DATA ON THEIR RESISTANCE

THERE are, at present, a great many excellent coils on the market for use in short-wave receivers. They are generally of the "plug-in" type so that different coils are used to obtain the various ranges required.

These coils should have as low a radio-frequency resistance as is possible, consistent with a construction sufficiently rugged to prevent their being damaged if they are handled somewhat roughly. It would be preferable if the coils could be wound on some solid form but the question then arises whether or not a form can be used without increasing the resistance of the coil to a considerable extent.

The General Radio Company has conducted some experiments along this line to determine just how much the form used affects the coil's resistance and also to determine what size wire is best to use. Tests were made using a standard bakelite form having a diameter of 2 3/4". The curve given on this Sheet indicates how the radio-frequency resistance of the coil varies with the size of the wire used. Evidently, from the curve, the wire size is not especially critical but best results are obtained with a wire size of about No. 12 or 14 gauge.

It was found that the use of good binders to hold the turns in place has no appreciable effect upon the resistance. A coil was wound in such a manner that a form could be slipped in and out of it without disturbing the wire. Measurements on the coil with and without the form indicated that the difference in efficiency was negligible.

Tests were also made with regard to shielding

and it was found that the shielding could be placed very near the coil and have no appreciable effect. The result of the tests may be summed up as follows:

When designing a coil for use on the 40-meter

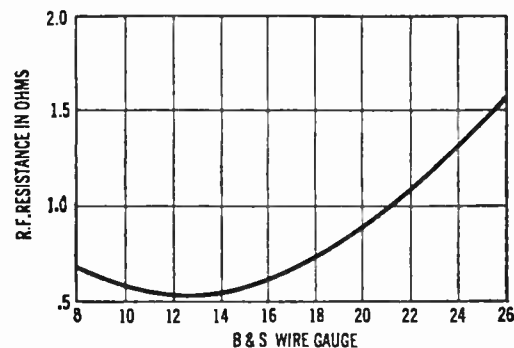

(7500-kc.) short-wave band (all these tests were made at this frequency), it is well to (1.) use about No. 12 to 14 wire; (2.) use a coil form if desired; (3.) use any good dope as a binder; (4.) use any reasonable amount of shielding where advantageous; (5.) keep the form factor (diameter divided by length) around 1 to 2.5.

These data are taken from the February, 1927, issue of the General Radio Experimenter.

No. 90

RADIO BROADCAST Laboratory Information Sheet

May, 1927

Loop Antennas

SOME OF THEIR ADVANTAGES

THE operation of a transformer is usually explained by saying that the current flowing in the primary sets up an alternating magnetic field which in turn causes a current to flow in the secondary. This is also the simplest way to explain the operation of a loop antenna, the only difference being that the alternating magnetic field that causes the current to flow in the loop is in the form of radio waves.

The number of volts induced in a loop by the passage of radio waves is:

$$2 \pi f n A H \times 10^{-8}$$

where H is the amplitude of the wave, f the frequency, n the number of turns in the loop, and A the area of the loop. The voltage calculated from this formula is only correct when the plane of the loop is vertical and perpendicular to the direction of the magnetic field. That is, the loop must be pointing toward the transmitting station. If rotated about a vertical axis only a quarter of a turn, no voltage will be induced.

This feature is the most important advantage of a loop, for two stations using exactly the same wavelength may often satisfactorily be separated (provided they do not lie in the same or exactly opposite directions) by simply turning the loop at right

angles to the interfering station. Loops are coming into greater use as transmitting stations become more powerful, and they will probably ultimately be used almost exclusively on account of the small space required, ease of installation, portability, lack of necessity to safeguard against lightning, and the improvement of the ratio of signal strength to interfering noises, due to their directional properties.

If a loop is compared in size to an antenna of the ordinary type it would appear that the amount of energy intercepted by the loop would be exceedingly small indeed. The fact is, however, that a good loop antenna, tuned with a condenser having low insulation losses, will pick up signals much better than might be expected from a comparison of its size to that of an outdoor antenna. This is due to the fact that the loop has a very much lower resistance than an elevated antenna.

The loop type antenna has been used most frequently in conjunction with super-heterodynes because, with this type of receiver, it is easy to obtain a large amount of radio-frequency amplification. During the last year, however, several receivers of the neutrodyne type have been placed on the market designed for use with a loop. These receivers are generally completely shielded so as to prevent interaction between the loop and the coils in the receiver.



Model AC-9

7-Tube, 2-Dial, Batteryless

This two-dial control set is designed especially for AC power, for use with the Amrad A B & C Power Unit. Easily operated, marvellous selectivity. Furnished with Power Unit but without tubes.

\$142

Console Model \$192



\$192.



Model S-733

7-Tube, 2-Dial, Battery Type

Owners of this Amrad Neutrodyne report complete satisfaction. High ratio vernier controls simplify tuning. Volume is controlled by a single adjustment. Beautifully designed cabinet finished in two-toned mahogany. Without accessories

\$77

Console Model \$127

AMRAD

7 tube Neutrodynes of Quality and Precision

AMRAD Neutrodynes are built with the greatest skill and precision. Each set must pass certain high standard tests before it leaves the factory.

The great skill and engineering feats of the Amrad Laboratories are manifest in the circuit as well as in the beautifully designed cabinets.

Produced under mass production methods influenced by Powel Crosley, Jr., combined with Amrad's engineering skill, these genuine neutrodynes are the greatest values on the market.

The console model AC-9-C is an unusual value. It is a 7-tube set with two-dial control. All the necessary power is furnished by the Amrad A B & C Power Unit, an efficient power supply tested under actual home conditions

for more than a year and operating from AC current, 100-120 volts, 60 cycle. No trickle charger is concealed in this unit. No more power supply troubles. Just snap the switch and set is in full operation. The cabinet is of beautiful two-toned mahogany finish, with the genuine Crosley musicone built in. This is a wonderful value at \$192, with the power unit, but without the tubes.

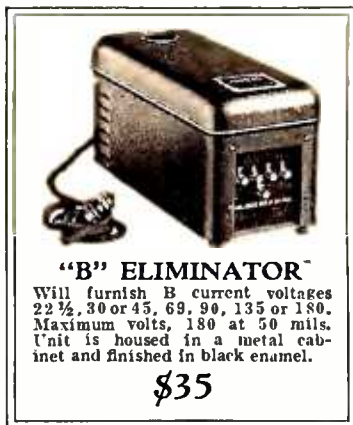

"B" ELIMINATOR

Will furnish B current voltages 22 1/2, 30 or 45, 69, 90, 135 or 180. Maximum volts, 180 at 50 mls. Unit is housed in a metal cabinet and finished in black enamel.

\$35

Write Dept. 2E7 for descriptive literature and information.

AMRAD CORPORATION

Medford Hillside, Mass.

Efficient 5 tube genuine Neutrodynes, unsurpassed in the radio market anywhere at this price!



\$60

Model S-522

5-Tube, 3-Dial, Battery Type

Amrad quality is again exemplified in this beautifully made and proportioned set. The simple, yet elegant lines of this set are pleasing to the eye. Actual reports of performance are remarkable. Simple to tune and easy to operate. Also made in console model at \$110.



\$125

Model AC-5

5-Tube, 3-Dial, Batteryless

A compact, efficient set delivering the utmost in radio enjoyment at the lowest possible cost. No batteries to fuss with. Operates direct from light current. Unusual selectivity, volume, and tone make this the greatest neutrodyne value on the market. Console Model \$175.

A Better Tuning Unit Was Never Devised



Officially Specified
for the
Hammarlund
—Roberts
“Hi-Q”
Receiver

THE Hammarlund “Auto-Couple” Unit combines scientifically the Hammarlund “Midline” Condenser with the Hammarlund Spacewound Coil to give automatic variable primary coupling at every condenser setting. This arrangement makes for maximum signal strength and selectivity at all wave-lengths and lessens the tendency of radio-frequency circuits to oscillate at the higher frequencies.

The “Midline” condenser has a full-floating rotor, with removable shaft. A longer shaft permits coupling together any number of condensers for single control.

The Hammarlund “Auto-Couple” Unit (condensers and coils may be purchased separately) is readily adapted to any radio-frequency circuit and when combined with Hammarlund Shields, Equalizers, and Balancing Condensers, will make your receiver the last word in modern radio reception.

Write for folder describing Hammarlund Products officially specified by twenty-eight prominent designers for their newest receivers.

HAMMARLUND MFG. CO.
424-438 W. 33rd Street New York City

For Better Radio
Hammarlund
PRECISION
PRODUCTS

No. 91

RADIO BROADCAST Laboratory Information Sheet

May, 1927

A Simple Tube Tester

HOW TO GET CHARACTERISTICS OF TUBES

CONTRARY to the opinion of many experimenters, a set-up of instruments to measure the characteristics of vacuum tubes is not excessively costly nor is it complicated. The diagram of connections of a tester is shown on Laboratory Sheet No. 92; this Laboratory Sheet will explain how to measure tube characteristics using the tester. The procedure can be explained most easily by taking an actual example.

Suppose we desire to measure the characteristics of a 201-A tube. We would first place the tube in the socket and then, with switch No. 2 in position B and switch No. 3 in position A, the rheostat would be adjusted until the filament voltage, as read on the voltmeter, is correct. In this case the correct voltage would be 5. Then, with switch No. 3 in position B the plate voltage is adjusted to 90 volts. The grid bias is next adjusted to 4.5 volts by throwing switches Nos. 1 and 2 to the A positions and adjusting the potentiometer P. The milliammeter will now read about 0.002 amperes (2 mA.). Note down the plate voltage, the grid voltage, and the resulting plate current.

Now adjust the potentiometer until the grid bias is, say 3.5, and read the plate current. It should read about 0.003 amperes (3 mA.). Leaving the grid bias at 3.5, next adjust the switches to read the plate voltage. Reduce the plate voltage so as to make the milliammeter read exactly the same as

before (2 mA.). The new reading of plate voltage may be 82. We now have all the necessary data to calculate the constants of the tube.

The amplification constant will be equal to the difference of the two plate voltages, 90-82, or 8, divided by the difference of the two grid voltages, 4.5-3.5 = 1. The amplification constant is therefore 8. The plate impedance is equal to the difference of the plate voltages divided by the difference in the plate currents, or 8 divided by 0.001. The quotient is 8000, which is the plate impedance. The mutual conductance is the plate current difference divided by the grid voltage difference, or 0.001 divided by 1 = 0.001 mhos or 1000 micromhos.

In measuring tube factors with this apparatus, care must be taken that the actual changes in voltages—and the corresponding current changes—are small. If the plate-current meter, and the grid-voltage meter, can be read with sufficient accuracy, very small changes should be made—say a plate voltage change of 5 volts. This, however, would make it necessary to read grid bias changes of less than a volt. The investigator, then, is between two fires in his endeavor to measure his tubes accurately. If he takes plate current readings resulting from large voltage changes, he gets a factor which represents working the tube over a large part of its characteristic curve. On the other hand, if he uses small voltage changes, the accuracy depends upon the accuracy of his meters and his ability to read them.

No. 92

RADIO BROADCAST Laboratory Information Sheet

May, 1927

Circuit Diagram of Tube Tester

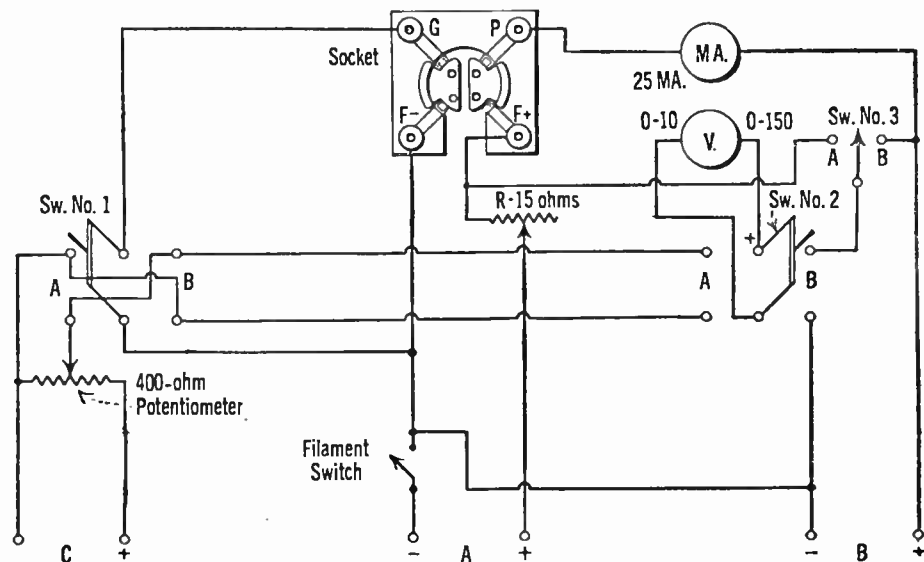

No. 93

RADIO BROADCAST Laboratory Information Sheet

May, 1927

Audio Amplifying Systems

DUAL-IMPEDANCE COUPLED AMPLIFIERS

ON THIS Sheet we give some facts regarding dual-impedance coupled amplifiers. A circuit diagram of such an amplifier will be found on Laboratory Sheet No. 87 (April, 1927).

Double-impedance amplifiers are capable of giving excellent results if care is taken in the selection of the apparatus and in the layout of the parts. The plate impedances should have an inductance around 100 henries; if the inductance is much less, the low frequencies will be lost. Well-made 0.1-mfd. blocking condensers are essential to prevent leakage.

The amplification of each stage is generally equal to about nine tenths of the amplification constant of the tube. If we lose one tenth on each stage, then the total amplification in three stages will be equal to $0.9 \times 0.9 \times 0.9 = 0.73$ times the product of the amplification constants of the three tubes concerned. Suppose two 201-A's, each with an amplification of eight, and one 171 with an amplification of three, are used. Then the total amplification will be equal to $8 \times 8 \times 3 \times 0.73 = 140.16$. This value is rather too low for best results, and for this reason high- μ tubes, having an amplification constant of anything up to about thirty, are generally used in this type of amplifier.

From some tests made in the Laboratory, it ap-

pears possible to overload the power stage of an impedance amplifier to a considerable extent, without introducing very objectionable distortion. This comes about in the following way.

In a transformer-coupled amplifier the maximum signal that can be placed on the grid is limited by the fact that, if the signal voltage is too large, grid current will flow in the grid circuit of the power tube. This current flowing through the secondary of the transformer saturates the core and prevents the transformer from properly amplifying the signal. In an impedance amplifier there are no transformers, and the grid current only has the effect of slightly lowering the inductance of the impedance unit in the power tubes's grid circuit. Slight overloading is therefore less noticeable in an impedance amplifier than in a transformer-coupled one.

As stated above, the amplification obtained at low frequencies depends upon the use of high-inductance impedances in the plate and grid circuits. There has however been a recent development in the design of double-impedance amplifiers by which it is possible to obtain very good low-note amplification without using very large coils. This design feature consists in so determining the inductance of the plate and grid coils and the capacity of the coupling condenser, that the entire combination tunes or resonates at about 30 cycles, with the result that the amplification of these low frequencies is unusually good.

play safe

The heart of the socket power unit is the variable resistor. Don't experiment with that important organ. Use CLAROSTAT. Its ability to cover the entire range and its current carrying capacity of 20 watts is essential if your unit is to furnish quiet, uniform power year after year.

CAUTION! CLAROSTAT is being imitated. Don't be misled. Insist on seeing the name which is stamped on every genuine CLAROSTAT.

25c never bought more value! "The Gateway to Better Radio" 32 pages of interesting reading, diagrams and illustrations covering everything in radio-amplification, transmission, socket power unit construction.

Send 25c in stamps or coin to American Mechanical Labs., Inc. 283 N. 6th St., Brooklyn, N.Y.



Thousands of Fans Say It's the Biggest Value in Radio

[You can Build It, Too]
[and Save \$50 to \$100]

MEN who take a real Scotch pride in getting the last penny's worth of value out of a radio set are the men we want to build the Hi-Q Shielded Receiver, for it is now a universally established fact that this set represents the fullest value in radio.

efficient circuit at any price. Its performance pleases even those radio experts who demand almost the impossible.



Get complete illustrated instruction book from any good dealer or send 25 cents

Any one can build the Hi-Q easily and successfully and save at least \$50 to \$100 over factory made sets of anything like similar efficiency. The approved parts (less cabinet) cost only \$63.05 including the simplified foundation unit.

Thousands of these remarkable receivers have been built at home by novices, amateurs and professional radio men. Universally the verdict is Success. There is no more

RADIO PANELS OF GENUINE BAKELITE

Cut, drilled and engraved to order. Send rough sketch for estimate. Our complete Catalog on Panels, Tubes and Rods—all of genuine Bakelite—mailed on request.

STARRETT MFG. CO. 521 S. Green Street Chicago, Ill.

Goodrich



Radio Panels

Black, Mahogany and Walnut. Standard thickness 3-16" and 1/4". High softening point prevents warping.

Low free sulphur content prevents discoloration.

Machine easier and are better electrically than any other material in common use.

Your radio dealer has them or will get them for you—if not, write to us and we will see that you are supplied.

Also hard rubber for coils, spaghetti tubing and miscellaneous rubber items for radio manufacturers.

Radio Sales Division

The B. F. Goodrich Rubber Company Established 1870 Akron, Ohio

Hammarlund ROBERTS Hi-Q

High Ratio of Reactance to Resistance High Ratio—Great Selectivity—Low Signals

HAMMARLUND-ROBERTS, Inc. 1182-A Broadway, New York City

ASSOCIATE MANUFACTURERS

Benjamin Elec. Mfg. Co.
Carter Radio Company
International Resistance Co.
(Durham Resistors)

Eby Mfg. Company
Hammarlund Mfg. Co.
Radiall Co. (Amperite)

Martin-Copeland Co.
Samson Electric Co.
Sangamo Electric Co.
Westinghouse Micarta

Hoyt

RADIO ROTARY METER



The Radio Dealer who services his customers' sets the most quickly and thoroughly, gains the most good will and profit. This HOYT Radio Rotary Meter gives him in one rugged, compact and accurate instrument, all the necessary 5 meter scales required for prompt and sure Radio service,—by a simple rotation of the meter case.

Send for 8-page book describing 20 Radio service tests with the HOYT Radio Rotary Meter.

BURTON-ROGERS CO.

Sales Dept. for HOYT Electrical Instrument Works 857 Boylston Street Boston, Mass. Send for booklet, "Hoyt Meters for Radio"



Amplion Cone

Cabinet Model A C 12 . . . \$30

Even the best radio set depends on the reproducer for its quality of tone.

In every test or comparison, the Amplion Cone quickly demonstrates how much the quality of reception is improved by this fine instrument.

Especially vocal
broadcasting

—the supreme test of a radio reproducer. With an Amplion Cone, all reproduction sounds natural and distinct.

Other Amplions
from \$12 to \$135

Write for Amplion literature
which illustrates and describes all models

THE AMPLION
CORPORATION OF
AMERICA

Dept. L, 280 Madison
Avenue, New York City

THE AMPLION
CORPORATION OF
CANADA, LTD.

Toronto, Ontario

AMPLION

No. 94

RADIO BROADCAST Laboratory Information Sheet

May, 1927

The Principle of Reflexing

AN EXPLANATION OF THE ACTION

WHEN a tube capable of amplifying a fairly strong signal is used to amplify a very weak one, it is evident that its power amplifying ability is not being made use of to the fullest possible extent. "Reflexing" is a system for getting more out of a tube by making it amplify two things—the incoming signal, which is a radio-frequency current, and the detected signal, which is an audio-frequency current. The accompanying diagram indicates a simple receiver using one stage of reflexed amplification.

In this receiver, the radio-frequency current enters the receiver via the antenna and is impressed on the tube by the tuned circuit, A. It then passes through the tubes and into the tuned transformer, B, the output of which is impressed on a crystal detector. The audio-frequency currents resulting from the detecting action of the crystal pass through the primary of the audio transformer, T. The voltage induced in the secondary of this transformer is impressed on the grid of the tube and is amplified. A pair of phones is used in the plate circuit of the tube for receiving the signal.

So long as the variations of potential due to these two different signals do not cause the tube to overload, neither interferes with the other. Some circuits use a reflex principle consisting of several stages of radio-frequency amplification and several stages of audio-frequency amplification. In such sets it is advantageous to use the system due to David Grimes and known as the Inverse Duplex

system. In this system, the tube handling the smallest amount of radio-frequency energy is made to handle the largest amount of audio-frequency energy and, vice versa, the tube handling the greatest

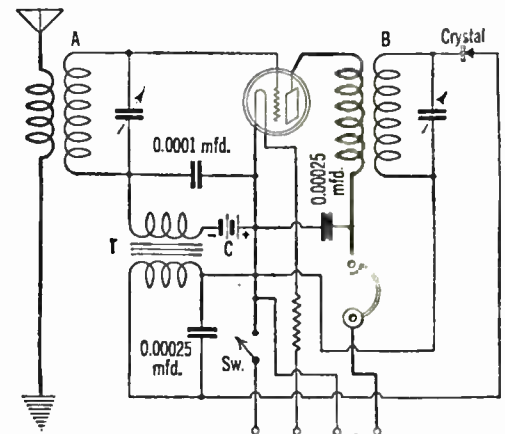

amount of radio energy handles the smallest amount of audio energy. In this way the point of overloading is not reached as quickly, and it is possible to obtain high efficiency from such a receiver.

No. 95

RADIO BROADCAST Laboratory Information Sheet

May, 1927

Storage Batteries

NECESSARY CARE

THE storage battery has been developed to a remarkable degree of perfection so that it will function over a long period of time with only a small amount of attention. Such attention consists more than anything else in keeping the battery properly filled with pure distilled water and correctly charged at all times. The efficiency and the life of the battery will decrease considerably if these two points are not carefully watched. The charging rate should be as close as possible to that recommended by the manufacturer, this information generally being given on the name plate of the battery. Although the state of charge of a battery can be measured with some accuracy by means of a voltmeter if the proper precautions are taken, the readings made in this way are not generally to be relied upon. A better method for use in testing a storage battery is to determine the state of charge by means of a hydrometer. The specific gravity, which is what the hydrometer measures, will be found to increase the reading of the hydrometer as the battery is charged, up to a certain point. The specific gravity reading for full charge is not the same for all batteries. For this reason, an endeavor should be

made to obtain from the manufacturer of the battery information regarding the hydrometer reading which should be obtained using his battery when it is fully charged and when it is fully discharged. Frequently, but not always, these same data will be found on the name plate. In the event that this information cannot be obtained, it is a safe rule to charge the battery until the hydrometer reading does not change during a period of one hour. When this condition holds true, the battery has absorbed all the charge possible. It will generally be found also that, when this condition of constant specific gravity reading throughout an hour is reached, the electrolyte will also begin to gas or bubble.

Care should be taken in charging the battery to make certain that its positive terminal is connected to the positive terminal of the source being used for charging purposes. If the battery is charged in the opposite direction the plates will be reversed in chemical character, and if the charging is continued for any great length of time, the battery will be destroyed. If a battery has only been charged in the wrong direction for a short length of time it can generally be brought back to normal by charging in the right direction for a very long time at a low charging rate.

No. 96

RADIO BROADCAST Laboratory Information Sheet

May, 1927

Analysis of Voice Frequencies

RELATIVE IMPORTANCE OF LOW AND HIGH FREQUENCIES

MANY investigations have been made to determine the relative importance of the various frequencies that are found in the human voice. For these investigations a high-quality audio amplifying system must be employed over which it is possible to hear equally as well as by direct transmission through the air.

Tests have been made by the Western Electric Company using such an amplifying system to determine the relative importance of different frequencies in the voice frequency range, and the results of these tests are shown in the curves on this sheet. These curves were obtained by inserting in the circuit low-pass (L.P.) filters, which will only pass low frequencies, and high-pass (H.P.) filters designed to pass no frequencies below a certain point. First of all let us consider the curve marked "Articulation H. P." The curve shows that the articulation was 40 per cent. when a high-pass filter was used that eliminated all frequencies below 2000 cycles. The articulation rises to 70 per cent. when a high-pass filter was used to cut off all frequencies below 1400 cycles. The curve marked "Energy L. P." shows that 60 per cent. of the total energy in the voice remained when a low-pass filter was used to cut off frequencies above 500 cycles.

These curves indicate, then, that the lower frequencies furnish most of the energy in the voice and that the higher frequencies are most important for proper articulation. If frequencies below 500 cycles are eliminated the energy is reduced 60 per

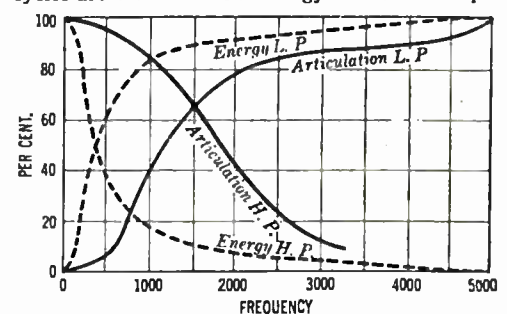

cent., and the articulation is only reduced 2 per cent. Eliminating all frequencies above 400 cycles leaves remaining 60 per cent. of the total energy but the articulation is only about 5 per cent.

The curves on this sheet were traced from an excellent book by K. S. Johnson entitled: *Transmission Circuits for Telephone Communication*.

Most from Your Tubes



The Watch Dog of your Tube

GOOD tubes are little better than poor tubes without Amperite. Utmost performance and longest life requires the perfect automatic filament control of each individual tube, afforded only by Amperite. Insist on this variable filament resistance—and look for the name. Eliminates hand rheostats. Simplifies wiring.

Radiall Book—FREE

Explains fully Amperite principle and operation. Gives season's best Hook-Ups and Construction Data. Send for it today to Dept. RB5

Radiall Co., 50 Franklin St., New York



Price \$1.10 mounted (U.S.A.) Sold Everywhere

AMPERITE

REG. U.S. PAT. OFF.

The "SELF-ADJUSTING" Rheostat

Newest Information TO SET BUILDERS



One of the outstanding developments of the present radio season is *Camfield's Super-Selective Nine*, a receiver featured by the Citizens Radio Call Book in their latest issue and tested in the greatest laboratory in the country. The *Super-Selective Nine* offers features never before incorporated in a radio set. Changes instantly from a 5-tube set to a 9-tube super. Simultaneous adjustment of selectivity and sensitivity creates remarkable reception. Be sure to build this circuit now. It will make money for you and make many friends too.

Send 25¢ for copy of our booklet today—now.

CAMFIELD RADIO MFG. CO.
357-359 E. Ohio St. Chicago, Ill.

This is a good time to subscribe for RADIO BROADCAST Through your dealer or direct, by the year only \$4.00 DOUBLEDAY, PAGE & CO. GARDEN CITY, NEW YORK

KARAS 23-Plate .0005 ORTHOMETRIC CONDENSERS

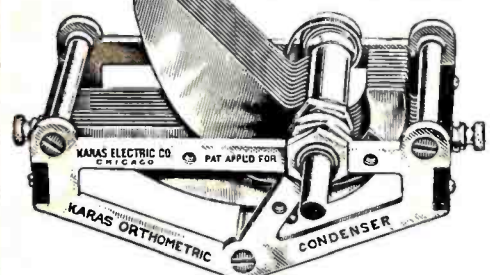

Makes Superheterodynes Amazingly Better!

KARAS 23-Plate .0005 Orthometric Straight Frequency Line Variable Condensers will make a vast improvement in any super in which they are used. When so much depends upon the variable condensers in your super, why not install Karas Orthometrics, and thus have the best condensers and the finest results? Order direct from us, using coupon below, if your dealer is out of stock. Pay postman on delivery—send no money.

KARAS ELECTRIC CO.
1065 Association Building Chicago

KARAS ELECTRIC CO., 1065 Association Bldg. Chicago
Send me Karas 23-plate Orthometric Condensers, price \$1 each, for which I will pay postman, plus postage, upon delivery.

Name.....
Address.....
City.....State.....
(If cash accompanies order, we will ship postpaid)

Radio Reception

depends primarily upon two things—
an EFFICIENT CIRCUIT and use of GOOD PARTS

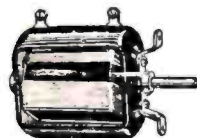

Type 269 Variometer Price \$5.00



Type 285 Audio Transformer Price \$6.00



Type 349 UX Tube Socket Price 50c



Type 410 Rheostat Price \$1.25

Always remember this fact is set-building—and remember that General Radio parts have long been recognized by radio editors, test laboratories, and experimenters as the universal standards of radio.

They have a laboratory background of over a decade.

The same outstanding craftsmanship and materials are embodied in General Radio parts for use in broadcast receivers as in General Radio apparatus used as precision standards in the leading radio and electrical laboratories of the world.

Whenever you find a popular circuit, you will invariably find General Radio parts—they are adapted to use in practically all of the better circuits.

Write for Catalog 926-B

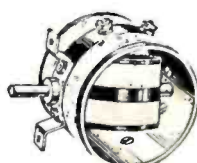

Type 268 Vario Coupler Price \$2.75



Type 277-D Coupling Coil Price \$1.50

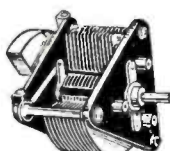

Type 247-F Condenser Price \$4.00



Type 368 Micro-Condenser Price \$1.50

GENERAL RADIO CO. Cambridge, Mass.

GENERAL RADIO PARTS and ACCESSORIES

The General Radio Company has endeavored to make it possible for the experimenter to obtain its products with minimum of effort. A careful selection of distributors and dealers has been made. They are best suited to serve you. If, however, you are unable to obtain our products in your particular locality, they will be delivered to you, postpaid, direct from the factory upon receipt of list price

Why not subscribe to Radio Broadcast? By the year only \$4.00; or two years \$6.00, saving \$2.40. Send direct to Doubleday, Page & Company, Garden City, New York.

I. C. A. PANELS OF INSULINE OR BAKELITE

The Official Panels for "R. B. Lab." and Other Popular Circuits

There's an I. C. A. panel for every popular circuit, engraved and drilled ready to assemble. An I. C. A. Panel gives you a regular "factory built" set. Also gives you highest insulating efficiency, which means better reception.

Other I. C. A. Insulating Parts for the "home set" builder include sub-panels, mounting brackets, binding post panels, tubing, rods, knife switches, etc.

Send for Free descriptive booklet B-5
INSULATING CO OF AMERICA, INC.
59 Warren Street New York City



Don't take substitutes for genuine I. C. A. Products. Write us if your dealer can't supply you.



Your Aerial is Subject to Lightning Induction



This Arrester Carries
\$100.00
 FREE INSURANCE

Safety Demands a BRACH Storm King ARRESTER

BECAUSE -
 It Gives Maximum Protection
 It Will Not Ground
 It Will Not Affect Reception
 It Carries \$100 Free Insurance

[20 Years Standard on
 America's Leading Railways]

OVER 2,000,000 RADIOS
 ARE PROTECTED BY
 BRACH ARRESTERS

Brach
 Radio Products
 L.S. BRACH MFG. CO.



NEWARK, N.J. TORONTO, CAN.

Equipment for the Home-Constructor

How to Use Some of the New Equipment Tested and Approved by the "Radio Broadcast" Laboratory

By THE LABORATORY STAFF

INTERFERENCE ELIMINATORS

MAN-MADE, as well as the natural sort of "static," will hinder the reception of radio signals. Fortunately, however, the former can be eliminated in almost all cases. Any kind of electrical spark will set up high-frequency oscillations similar to those used for broadcasting, the difference between the two being that the electrical spark from a motor or other household appliance is of an intermittent and varying intensity, which results only in noise in the receiver. There are many classes of electrical apparatus which can cause interference, such as oil burners, battery chargers, violet ray apparatus, etc. The commutator type of motor commonly used in connection with household appliances is one of the most common offenders. The spark takes place at the commutator, but the high-frequency oscillations may be carried along wires for a block or more and blanket reception over a large area.

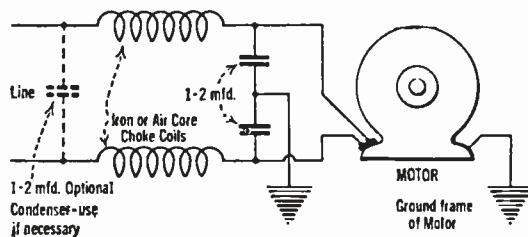

FIG. 1

A combination of fixed condensers and choke coils, placed in the electric line near the offending apparatus, will usually eliminate, or at least greatly reduce, the interference from this source. The common connections of such a filter apparatus are shown in Fig. 1. A choke coil is placed in each leg of the line supplying the motor or other apparatus. These coils have a high impedance to high-frequency oscillations, and are usually of approximately 200 millihenries inductance. They should be wound with wire heavy enough to carry the current required without undue heating. Chokes of this character may be constructed by winding 175 turns of No. 16 d.c.c. on a porcelain tube 1 inch in diameter and 12 inches long. The condensers act as a by-path to ground for the high-frequency current. The value of these condensers may be from 1 to 2 microfarads, depending upon the nature of the interference. Sometimes another condenser, shown by the dotted lines, is placed across the line side of the filter. These condensers should have a high enough working voltage to take care of any voltage which may be impressed on them.

There are several interference filters on the market, two of which are shown in the photograph. While the circuit diagram given may not be exactly that used in the commercial type of filter, these latter are all based on the same general principle. In each device there are five wires leading out of the case, two of which go to the electric line, two to the motor or other apparatus, and the fifth to the grounded frame of the motor. The Tobe Interference Filter No. 1 is made by the Tobe-Deutschmann Company, of Cambridge, Massachusetts, and sells for \$15.00.

This filter is designed for household appliances and will work effectively on motors up to $\frac{1}{4}$ horsepower, and may be used on d.c. or a.c. lines. It is understood that these filters may be obtained, by special order, for installations of as high as 500-kilowatts and 1000 volts potential. The Day-Fan Electric Company, of Dayton, Ohio, also make a filter, known as the "Quietus," which is obtainable in two models, one, the No. 6001, for general use in the home, which sells for \$10.00, and another, the No. 6003, for use with a household lighting plant, such as the Delco-Light, which is priced at \$8.00.

RESISTORS FOR SOCKET-POWER DEVICES

RESISTORS designed for use in socket-power devices may be of the wire-wound type or of the metallic filament type, but in every case, they must be designed to dissipate the heat generated fast enough so that they will not burn out. Some manufacturers rate their resistors according to how much current may be carried with safety, while others rate them in watts. To choose the correct resistance when the rating is given in current, the amount of current which is to flow in the circuit must be known. This may be measured or it may be calculated by Ohm's Law. For instance, if the resistance is 1000 ohms and the voltage 100, the voltage divided by resistance will give the amount of current which will flow, which in this case is 0.10 amperes (100 milliamperes). The current-carrying capacity of the resistor should therefore be rated at 100 or more mils. In the case of the resistor rated in watts, the procedure is slightly different. The wattage is found by multiplying the voltage by the current, or in the case of the above resistor, the voltage (100) times the current (0.10) gives us 10 watts. That is, a 1000-ohm resistor having a rating of 10 watts would carry the 100 milliamperes with-



RADIO BROADCAST Photograph

THE "QUIETUS" AND TOBE-DEUTSCHMANN INTERFERENCE FILTERS

out overheating. Another way in which the carrying capacity may be figured is by the formula in which watts are equal to the current squared times the resistance. Transposing the formula we get:

$$I = \sqrt{W/R}$$

where I is the current, w is the watts rating, and R is the resistance. Substituting the actual values

where $R = 1000$ ohms and $w = 10$, in the above formula, we have 1 equal to the square root of $10 + 1000$. Taking the square root, we obtain the safe carrying capacity in current as 0.1 amperes, or 100 milliamperes.

The resistances of various units as measured in the Laboratory by means of the Wheatstone bridge were found to differ by about 3 per cent. from the rated value, which is close enough for all ordinary purposes. Resistors of this type are made by Amsco Products, Incorporated, New York City; Ward-Leonard Electric Company, Mount Vernon, New York; the Tobe-Deutschmann Company (Veritas), Cambridge, Massachusetts; Arther H. Lynch, Inc., New York, and the C. E. Mountford Company (Kroblak), New York City.

SHIELDS

ARGUMENTS still continue among engineers, experimenters, and home-constructors, regarding the shielding of radio broadcast receivers. Some say that coils, condensers, etc., if properly designed and properly spaced in the receiver, will need no shielding, while others claim that shielding is an absolute necessity.

Until quite recently the home-constructor was hampered in the use of shielding, because he had no tools for working the material; besides, the latter was hard to get. Several types of aluminum box shields can now be had, and they may easily be incorporated in almost any receiver requiring a shield. These shields usually come in knock-



RADIO BROADCAST Photograph

INDIVIDUAL STAGE SHIELDS

down form, and may easily be assembled by means of ingeniously designed corner strips. Their size is sufficient to allow a tube, radio-frequency transformer, and variable condenser to be mounted within them without coming too close to the sides. If the size is not exactly right they may be cut down before assembly, as they are in flat pieces. An accompanying photograph shows one of these shield boxes, made by the Aluminum Company of America, both in knocked-down and assembled form. The Aluminum Company's box is 12 gauge, 6 inches high, 5 inches wide, and 9 inches deep, and is sold for \$3.00. The Hammarlund Manufacturing Company's box shield is 22 gauge, 5 3/4 inches high, 6 inches wide, and 9 inches deep, and sells for \$2.00. The Silver-Marshall Company makes a shield of this type which, however, is not knocked down. The box is 21 gauge, 5 inches high, 3 3/4 inches wide, and 7 1/2 inches deep. The price is \$2.00.

SOCKET-POWER UNITS

THE Balkite socket-power B units are all of the electrolytic type, having eight cells in series which rectify the a.c. current from the line.



RADIO BROADCAST Photograph

THE BALKITE "KX" UNIT

These cells are of the acid type having one electrode of lead and the other of a special material. As a rule, this type of rectifier, combined with the proper transformers, chokes, and condensers gives very quiet operation, and the only attention required is the addition of pure water at intervals of several months to take care of the evaporation which naturally takes place.

In the instructions accompanying the apparatus, it is stated that the formation of a brown or white sludge in the bottom of the cell is a normal condition and no attention should be paid to it. The solution sometimes turns pink, and this also may be regarded as natural. It should never be necessary to replace the electrolyte except in case of accident when the solution is spilled. A new solution should be obtained from the manufacturer or from the dealer who sold the unit. If the electrolyte gets spilled in the metal case, the whole unit should be shipped back to the factory immediately for a thorough cleaning, otherwise the acid may cause considerable damage to the electrical mechanism in the device and cause it to cease functioning.

Sometimes when the electrolytic type of rectifier is left for some time without being operated, a thin film of sulphate will form on the surface of the electrodes which will materially lower the output voltage. There are two methods of bringing the unit back to normal. For ordinary cases, the unit should be disconnected from the receiver and a short circuiting wire connected across the output terminals marked "High" and "Negative." The line current is then turned on for half an hour, after which the jumper wire is disconnected and the unit is again hooked up to the receiver, and normal operation should be obtained. Another method which may be used is to put a jumper across the output as before and then short out half of the rectifier cells at a time for a period of about thirty seconds. In the Laboratory the breaking down of the sulphate film was tried out, the voltage, in one case, being raised from 125 to 140 volts. On one of the smaller units, the voltage was raised from 105 to 120 volts. Both units had been standing for some time. One model, the type KX, which includes a trickle charger in the same case, is shown in the accompanying photograph on this page.

A table of the price list and capacities is appended at the bottom of this page. All of these Balkite units are for use with 110 to 120 volts a.c. Models are sold for either 50 or 60 cycles. They are manufactured by Fansteel Products, Incorporated, of North Chicago, Illinois.

MODEL	WATTS CONSUMPTION	TERMINALS	NO. OF TUBES	CAPACITY	PRICE
B -W	7	Det., Amp., B neg.	5 or less	67-90 volts, 20 mils.	\$27.50
B -X	12	Det., Low, Med., High, B neg.	5 to 8	135 volts, 30 mils.	42.00
B -Y	17	Det., Low, Med., High, Power, Gnd., B neg.	Any receiver	150 volts, 40 mils.	69.00
KX*	15	Det., Low, Med., High, A plus, A minus, B neg.	5 to 8	135 volts, 30 mils.	59.50

*Includes a trickle charger for the A battery.

PRICE LIST AND CAPACITIES OF BALKITE UNITS

ASK... ANY... RADIO... ENGINEER



The "Mountie" isn't lonely any more

WHEN the supply ship steams south from the last outpost of civilization in September, not to return until the following July, loneliness will never again beset the lives of the Royal Canadian Mounted Police who patrol that vast, wild area.

Radio is now brightening the long winter nights with music, special programs, messages and greetings from their "home folks."

And in the receiving sets of the "Mounties" is the best equipment obtainable. The batteries they use *must* be dependable. They *must* serve until new supplies are brought in a year later.

Ask any Radio Engineer

BURGESS BATTERY COMPANY
GENERAL SALES OFFICE: CHICAGO
Canadian Factories and Offices:
Niagara Falls and Winnipeg



BURGESS
RADIO BATTERIES

Here's Work That is Almost ROMANCE!



EARN BIG MONEY in RADIO

Get into the great new BIG-Pay Industry—Radio. If you're earning a penny less than \$50 a week, clip coupon now. Send for 64-page FREE BOOK. Be a Radio Expert, and draw down big money for this easy, fascinating work. Positions everywhere. Need for Radio Experts in every community. Short hours. BIG PAY. Free book gives all the facts.

Learn Quickly and Easily at Home

Skilled Radio Engineers will show you how to qualify, quickly and easily at home, for Radio's fine jobs. We train you completely and thoroughly. Hundreds of N. K. I. trained men are today holding down good big jobs in the Radio field. Hundreds of opportunities now awaiting the trained man. FREE EMPLOYMENT SERVICE. Many other big features. Get the facts—CLIP COUPON.



"My charges for consultation \$2.50 per hour. All success due to you." R. W. Blackhill, Brooklyn



"Radio a gold mine—your course worth thousands." A. R. Herke, Winnipeg

Get This FREE BOOK!

Send coupon below for FREE BOOK—"Rich Rewards in Radio." Read for yourself. No previous experience needed. Common schooling enough. WRITE NOW.



Materials for building up-to-date receiving sets and to construct 50 well-known Radio circuits included to help you learn. An UNEQUALLED OFFER. Other special features now being offered, so Act Quick!

NATIONAL RADIO INSTITUTE
Dept. E-94, Washington, D. C.

MAIL COUPON

National Radio Institute,
Dept. E-94, Washington, D. C.

Without obligating me in any way, please send me your free book, "Rich Rewards in Radio," also complete information on your practical, home study Radio course.

Name

Address

Town.....State.....

A KEY TO RECENT RADIO ARTICLES

By E. G. SHALKHAUSER

THIS is the nineteenth installment of references to articles which have appeared recently in various radio periodicals. Each separate reference should be cut out and pasted on 4" x 6" cards for filing, or pasted in a scrap book either alphabetically or numerically. An outline of the Dewey Decimal System (employed here) appeared last in the January RADIO BROADCAST.

R1450. BROADCASTING. **BROADCASTING**
Popular Radio, Jan., 1927, Pp. 11-ff. *Who Pays for, Who Pays for,*
"Who Pays the Broadcaster?" O. E. Dunlap, Jr.
The problem of supporting radio broadcast programs, either through actual contributions by the listening public, or through indirect channels, such as advertising, and thus creating good will and deriving publicity, is discussed. A list of sponsors of various program features, and the stations broadcasting, is tabulated, showing what is being done to-day in furnishing entertainment. A chart is also appended stating the toll charges of the various stations for given periods of time on the air.

R1412. RESONANCE. **RESONANCE,**
Popular Radio, Jan., 1927, Pp. 31-ff. *Tuning.*
"What Happens When You Tune Your Set," Sir Oliver Lodge.

A simple treatise on the conversion of radio waves into electrical impulses in the tuning circuits of the radio set and its analogy to mechanical or sound resonance is given in this second of a series of articles. The function of the detector tube is clearly outlined.

R620.08. INSTALLATIONS. **INSTALLATIONS,**
Bureau of Standards Handbook No. 9. *Safety Rules.*
"Safety Rules for Radio Installations."
The material contained herein is a reprint of Part 5 of the National Electrical Safety Code, dealing with proper radio installations as approved by the American Engineering Standards Committee.

R000. HISTORY. **HISTORY**
Radio Service Bulletin, Dec. 31, 1926, Pp. 24-32.
"Important Events in Radio—Peaks in the Waves of Wireless Progress."

A brief outline of the important happenings in the history of radio, opposite the year in which these events occurred, is given. Starting with the year 1827, when the principle of magnetism was first discovered, and leading down through the year 1926, the progress made in radio is presented.

R550. BROADCASTING. **BROADCASTING,**
Radio Service Bulletin, Dec., 31, 1926.
Pp. 9-21. *List of Stations.*
"Broadcasting Stations, Alphabetically by Call Signals."
A list of broadcasting stations, giving call signals, location of station, owner of station, power, wavelength, and frequency, is presented. The list is complete up to December 31, 1926. This publication may be procured from the Superintendent of Documents, Government Printing Office, Washington, District of Columbia, at five cents per copy.

R330. ELECTRON TUBES. **ELECTRON TUBES,**
Radio, Jan., 1927, Pp. 20-ff. *4 Element.*
"The Shielded Grid Vacuum Tube." E. F. Turner, Jr.
By placing a second grid between the plate and the control grid of a vacuum tube, Doctor Hull, of the General Electric Company, has succeeded in reducing inter-electrode capacity between the elements of the tube. This second grid is said to act as an electrostatic shield when positively charged. It is composed of a number of flat circular discs, or rings, 3 mm. wide and spaced 3 mm. apart. The characteristics of the tube are discussed.

R344.5 ALTERNATING CURRENT SUPPLY. **SOCKET-POWER**
Radio, Jan., 1927, Pp. 23-24. **DEVICE,**
A Battery.
"A Home-Built A Battery Eliminator," G. M. Best.
Constructional data concerning a 2-ampere A battery eliminator employing a transformer, chokes, two tungar 2-ampere bulbs, and electrolytic condensers or rheostats, are presented.

R382. INDUCTORS. **INDUCTORS,**
Radio, Jan., 1927, Pp. 26-27. *Chart.*
"A Reversible Inductance Chart," A. C. Kulmann.
A very comprehensible and useful inductance chart for single-layer solenoids, giving either the inductance of a coil or the coil size required for a given inductance, is shown. The range in inductance is from 4 to 20,000 microhenries. The use of the chart is illustrated.

R134.8. REFLEX ACTION. **REFLEX**
Radio, Jan., 1927, Pp. 20ff. **ACTION.**
"More About the New Inverse Duplex," D. Grimes.
In this second of a series of articles on the new Inverse Duplex System, complete data on the construction of the separate coils, data on wiring and assembly, and elimination of trouble that might occur, are given.

R343. ELECTRON-TUBE RECEIVING SETS. **RECEIVER,**
Radio, Jan., 1927, Pp. 30ff. *Infradyne.*
"How and Why the Infradyne Works," R. B. Thorpe.
The writer discusses theoretically the operation of the new infradyne receiving circuit, analyzing the action taking place within the various parts of the circuit. Various diagrams and graphs are shown, in order to explain clearly the arrangement employed.

R344.3. TRANSMITTING SETS. **TRANSMITTERS,**
Proc. I. R. E., Jan., 1927, Pp. 9-36. *Crystal-Controlled.*
"Piezo-Electric Crystal-Controlled Transmitters," A. Crossley.
A discussion of piezo-electric crystals and the early history of the development of the art are given.

The development of crystal-controlled vacuum-tube oscillators by the Naval Research Laboratory is outlined, and various means of amplifying the output of a crystal-controlled oscillator are cited, the best method being described. This method consists of balancing or neutralizing the various stages of amplification and also observing proper precautions for reducing grid circuit losses by using high values of biasing voltage.

R344. ELECTRON-TUBE GENERATORS. **ELECTRON-TUBE**
Proc. I. R. E., Jan., 1927, Pp. 37-39. **GENERATOR.**
"Simultaneous Production of a Fundamental and a Harmonic in a Tube Generator," H. J. Walls.

A method whereby a single generator tube may be used to transmit two frequencies simultaneously, thus eliminating the necessity of using two separate tubes, is described. In addition to the fundamental, some harmonic is amplified in a separate oscillating circuit. A broadcasting station may thus send out the same modulated energy on two frequencies using but one transmitter.

R113.1. FADING. **FADING.**
Proc. I. R. E., Jan., 1927, Pp. 41-47. *Recorder for.*
"An Automatic Fading Recorder," T. A. Smith and G. Rodwin.

A device for automatically recording signal intensities is described, with the method employed to amplify the signal sufficiently to operate a commercial type graphic meter. Sample fading records of various transmissions are also presented.

R331. CONSTRUCTION; EVACUATION **ELECTRON TUBES,**
OF TUBES.
Proc. I. R. E., Jan., 1927, Pp. 49-55. *Alkali Vapor.*
"Behavior of Alkali Vapor Detector Tubes," H. A. Brown and C. T. Knipp.

The comparative efficiency of gas-filled tubes now on the market, and certain potassium sodium alloy tubes, is described. It is shown how the operation of gas-filled tubes depends on the temperature of the gas and the tube walls. It is also shown how these K Na tubes compare with the 201-A and the 200 type tubes, and that the K Na tubes are ideal for durability, true tone reproduction, and non-critical adjustment of plate and filament voltage.

International Short-Wave Test

FROM April 18th to 30th, short-wave tests on 7000-kc. (43 meters) will be conducted from WAQ-2 XAI, the Westinghouse experimental station at Newark, New Jersey. The schedule is: 8 to 8:30 P. M. (Eastern Standard Time) "ABC de 2 XAI" sent automatically on a crystal-controlled transmitter. From 8:30 to 9, amateurs will be worked and other tests made. The manager of the station, E. Gundrum, Westinghouse Electric & Manufacturing Company, Plane and Orange Streets, Newark, New Jersey, welcomes reports on audibility, fading, and keying, from listeners throughout the world. Reports should be forwarded either to RADIO BROADCAST or directly to the station.

TECHNICAL INFORMATION INQUIRY BLANK

Technical Service,
RADIO BROADCAST LABORATORY,
Garden City, New York.

GENTLEMEN:

Please give me fullest information on the attached questions. I enclose a stamped addressed envelope.

I am a subscriber to RADIO BROADCAST, and therefore will receive this information free of charge.

I am not a subscriber and enclose \$1 to cover cost of the answer.

NAME.....

ADDRESS.....R. B. M.

Manufacturers' Booklets Available

A Varied List of Books Pertaining to Radio and Allied Subjects Which May Be Obtained Free by Using the Accompanying Coupon

AS AN additional service to RADIO BROADCAST readers, we print below a list of booklets on radio subjects issued by various manufacturers. The publications listed below cover a wide range of subjects, and offer interesting reading to the radio enthusiast. The manufacturers issuing these publications have made great effort to collect interesting and accurate information. RADIO BROADCAST hopes, by listing these publications regularly, to keep its readers in touch with what the manufacturers are doing. Every publication listed below is supplied free. In ordering, the coupon printed on page 62 must be used. Order by number only.—THE EDITOR.

1. FILAMENT CONTROL—Problems of filament supply, voltage, regulation, and effect on various circuits. RADIALL COMPANY.
2. HARD RUBBER PANELS—Characteristics and properties of hard rubber as used in radio, with suggestions on how to "work" it. B. F. GOODRICH RUBBER COMPANY.
3. TRANSFORMERS—A booklet giving data on input and output transformers. PACENT ELECTRIC COMPANY.
4. RESISTANCE-COUPLED AMPLIFIERS—A general discussion of resistance coupling with curves and circuit diagrams. COLE RADIO MANUFACTURING COMPANY.
5. CARBORUNDUM IN RADIO—A book giving pertinent data on the crystal as used for detection, with hook-ups, and a section giving information on the use of resistors. THE CARBORUNDUM COMPANY.
6. B-ELIMINATOR CONSTRUCTION—Constructional data on how to build. AMERICAN ELECTRICAL COMPANY.
7. TRANSFORMER AND CHOKE-COUPLED AMPLIFICATION—Circuit diagrams and discussion. ALL-AMERICAN RADIO CORPORATION.
8. RESISTANCE UNITS—A data sheet of resistance units and their application. WARD-LEONARD ELECTRIC COMPANY.
9. VOLUME CONTROL—A leaflet showing circuits for distortionless control of volume. CENTRAL RADIO LABORATORIES.
10. VARIABLE RESISTANCE—As used in various circuits. CENTRAL RADIO LABORATORIES.
11. RESISTANCE COUPLING—Resistors and their application to audio amplification, with circuit diagrams. DEJUR PRODUCTS COMPANY.
12. DISTORTION AND WHAT CAUSES IT—Hook-ups of resistance-coupled amplifiers with standard circuits. ALLEN-BRADLEY COMPANY.
13. B-ELIMINATOR AND POWER AMPLIFIER—Instructions for assembly and operation using Raytheon tube. GENERAL RADIO COMPANY.
14. B-ELIMINATOR AND POWER AMPLIFIER—Instructions for assembly and operation using an R. C. A. rectifier. GENERAL RADIO COMPANY.
15. VARIABLE CONDENSERS—A description of the functions and characteristics of variable condensers with curves and specifications for their application to complete receivers. ALLEN D. CARDWELL MANUFACTURING COMPANY.
16. BAKELITE—A description of various uses of bakelite in radio, its manufacture, and its properties. BAKELITE CORPORATION.
17. POWER SUPPLY—A discussion on power supply with particular reference to lamp-socket operation. Theory and constructional data for building power supply devices. ACME APPARATUS COMPANY.
18. AUDIO AMPLIFICATION—A booklet containing data on audio amplification together with hints for the constructor. ALL-AMERICAN RADIO CORPORATION.
19. HIGH-FREQUENCY DRIVER AND SHORT-WAVE WAVE-METER—Constructional data and application. BURGESS BATTERY COMPANY.
20. AUDIO-FREQUENCY CHOKES—A pamphlet showing positions in the circuit where audio-frequency chokes may be used. SAMSON ELECTRIC COMPANY.
21. RADIO-FREQUENCY CHOKES—Circuit diagrams illustrating the use of chokes to keep out radio-frequency currents from definite points. SAMSON ELECTRIC COMPANY.
22. TRANSFORMER AND IMPEDANCE DATA—Tables giving the mechanical and electrical characteristics of transformers and impedances, together with a short description of their use in the circuit. SAMSON ELECTRIC COMPANY.
23. BYPASS CONDENSERS—A description of the manufacture of bypass and filter condensers. LESLIE F. MITER COMPANY.
24. AUDIO MANUAL—Fifty questions which are often asked regarding audio amplification, and their answers. AMERTRAN SALES COMPANY, INCORPORATED.
25. SHORT-WAVE RECEIVER—Constructional data on a receiver which, by the substitution of various coils, may be made to tune from a frequency of 16,660 kc. (18 meters) to 1999 kc. (150 meters). SILVER-MARSHALL, INCORPORATED.
26. AUDIO QUALITY—A booklet dealing with audio-frequency amplification of various kinds and the application to well-known circuits. SILVER-MARSHALL, INCORPORATED.
27. VARIABLE CONDENSERS—A bulletin giving an analysis of various condensers together with their characteristics. GENERAL RADIO COMPANY.

28. FILTER DATA—Facts about the filtering of direct current supplied by means of motor-generator outfits used with transmitters. ELECTRIC SPECIALTY COMPANY.
29. RESISTANCE COUPLING—A booklet giving some general information on the subject of radio and the application of resistors to a circuit. DAVEN RADIO CORPORATION.
30. RESISTORS—A pamphlet giving some technical data on resistors which are capable of dissipating considerable energy; also data on the ordinary resistors used in resistance-coupled amplification. THE CRESCENT RADIO SUPPLY COMPANY.
31. RADIO-FREQUENCY AMPLIFICATION—Constructional details of a five-tube receiver using a special design of radio frequency transformer. CAMFIELD RADIO MANUFACTURING COMPANY.
32. FIVE-TUBE RECEIVER—Constructional data on building a receiver. AERO PRODUCTS, INCORPORATED.
33. AMPLIFICATION WITHOUT DISTORTION—Data and curves illustrating the use of various methods of amplification. ACME APPARATUS COMPANY.
34. RADIO HANDBOOK—A helpful booklet on the functions, selection, and use of radio apparatus for better reception. BENJAMIN ELECTRIC MANUFACTURING COMPANY.
35. SUPER-HETERODYNE—Constructional details of a seven-tube set. G. C. EVANS COMPANY.
36. IMPROVING THE AUDIO AMPLIFIER—Data on the characteristics of audio transformers, with a circuit diagram showing where chokes, resistors, and condensers can be used. AMERICAN TRANSFORMER COMPANY.
37. DISTORTIONLESS AMPLIFICATION—A discussion of the resistance-coupled amplifier used in conjunction with a transformer, impedance, or resistance input stage. Amplifier circuit diagrams and constants are given in detail for the constructor. AMSCO PRODUCTS INCORPORATED.
38. PLATE SUPPLY SYSTEM—A wiring diagram and layout plan for a plate supply system to be used with a power amplifier. Complete directions for wiring are given. AMERTRAN SALES COMPANY.
39. FIVE-TUBE RECEIVER—Data are given for the construction of a five-tube tuned radio-frequency receiver. Complete instructions, list of parts, circuit diagram, and template are given. ALL-AMERICAN RADIO CORPORATION.
40. BETTER TUNING—A booklet giving much general information on the subject of radio reception with specific illustrations. Primarily for the non-technical home constructor. BREMER-TULLY MANUFACTURING COMPANY.
41. SIX-TUBE RECEIVER—A booklet containing photographs, instructions, and diagrams for building a six-tube shielded receiver. SILVER-MARSHALL, INCORPORATED.
42. SOCKET POWER DEVICE—A list of parts, diagrams, and templates for the construction and assembly of socket power devices. JEFFERSON ELECTRIC MANUFACTURING COMPANY.
43. FIVE-TUBE EQUAMATIC—Panel layout, circuit diagrams, and instructions for building a five-tube receiver, together with data on the operation of tuned radio-frequency transformers of special design. KARAS ELECTRIC COMPANY.
44. FILTER—Data on a high-capacity electrolytic condenser used in filter circuits in connection with A socket power supply units, are given in a pamphlet. THE ABOX COMPANY.

ACCESSORIES

22. A PRIMER OF ELECTRICITY—Fundamentals of electricity with special reference to the application of dry cells to radio and other uses. Constructional data on buzzers, automatic switches, alarms, etc. NATIONAL CARBON COMPANY.
23. AUTOMATIC RELAY CONNECTIONS—A data sheet showing how a relay may be used to control A and B circuits. YAXLEY MANUFACTURING COMPANY.
24. ELECTROLYTIC RECTIFIER—Technical data on a new type of rectifier with operating curves. KODEL RADIO CORPORATION.
25. DRY CELLS FOR TRANSMITTERS—Actual tests given, well illustrated with curves showing exactly what may be expected of this type of B power. BURGESS BATTERY COMPANY.
26. DRY-CELL BATTERY CAPACITIES FOR RADIO TRANSMITTERS—Characteristic curves and data on discharge tests. BURGESS BATTERY COMPANY.
27. B BATTERY LIFE—Battery life curves with general curves on tube characteristics. BURGESS BATTERY COMPANY.
28. HOW TO MAKE YOUR SET WORK BETTER—A non-technical discussion of general radio subjects with hints on how reception may be bettered by using the right tubes. UNITED RADIO AND ELECTRIC CORPORATION.
29. TUBE CHARACTERISTICS—A data sheet giving constants of tubes. C. E. MANUFACTURING COMPANY.
30. FUNCTIONS OF THE LOUD SPEAKER—A short, non-technical general article on loud speakers. AMPLION CORPORATION OF AMERICA.
31. METERS FOR RADIO—A catalogue of meters used in radio, with connecting diagrams. BURTON-ROGERS COMPANY.
32. SWITCHBOARD AND PORTABLE METERS—A booklet giving dimensions, specifications, and shunts used with various meters. BURTON-ROGERS COMPANY.
33. COST OF B BATTERIES—An interesting discussion of the relative merits of various sources of B supply. HARTFORD BATTERY MANUFACTURING COMPANY.



Trade Mark Reg'd. U. S. Pat. Office



TINYTOBES

The TINYTOBE Condenser, shown in actual size here, is a new product and is available in capacities from .00007 to .02 Mfd. For continuous operation at voltages up to 1000 volts D.C. It is so small and light that it can be soldered directly into the circuit without other support.

Prices range from 35c for .00007 Mfd. to 60c for the .02 Mfd.



A special-purpose condenser made for the Radiola No. 104 Loud Speaker, and made to stand up in continuous use. It fits the space provided exactly. Price, \$7.00.



The first condenser B-BLOCK specifically designed for use with the Thordarson Power Compact Type R-171 is the TOBE B BLOCK Type R-171. The terminals are arranged so that they come close to those on the Thordarson Power Compact for minimum time and length of wiring. Short-path, non-inductive condensers are used for increased efficiency. The price is \$12.00. Thordarson makes a 210 unit also, and there is the TOBE B-BLOCK Type R-210 to go with it. Price, \$13.00.



The TOBE 600 Line

High-voltage condensers for AmerTran and similar high-voltage packs. Big, husky 1000-volt D.C. continuous-operating voltage condensers—made to stand the gaff. Equipped with TOBE safety terminals.

Prices

No. 650—0.5 Mfd.	\$2.00
No. 601—1.0 Mfd.	2.50
No. 602—2.0 Mfd.	3.50
No. 604—4.0 Mfd.	6.00

Write us for information on the TOBE Radio Interference Filters. They are made to reduce man-made static. Ask for Pamphlet B-S.

Tobe Deutschmann Co.

Engineers & Manufacturers of Technical Apparatus

Cambridge

Mass.

Now
rejuvenate
your
hard-worked
tubes!



NIGHT after night for hours at a time those tubes of yours have been hard at it. Now they are getting a little jaded, in no shape to make good in the coming months of "not so good" radio reception. But just plug them into a Sterling Meter Equipped Tube Reactivator, turn on the current for a few minutes and your tubes will be restored to their normal strength.

The Sterling Reactivator works wonders with old tubes so long as the filament isn't burned out.

Model R-403 for large and small tubes, \$12.50.

Or
test them
for performance
with the Sterling
"Home" Tube Tester

Knowing what's wrong is more than half the battle for perfect radio reception. And more often than not the trouble comes from the tubes. The only

way to find this out is to have a reliable tube tester on hand when you need it. The Sterling Tube Tester tells you at a glance the exact condition of your tubes. In simple language too. No computations to make. Just plug in and read "good", "fair" or "poor".

Model R-411 for large tube \$7.50
for small tube \$8.50

See your dealer about these two essential radio devices.

Sterling

RADIO NECESSITIES

Send for booklet "J" telling about the complete line of Sterling Radio Equipment

THE STERLING MFG. CO.

2831 Prospect Ave.

Cleveland



35. STORAGE BATTERY OPERATION—An illustrated booklet on the care and operation of the storage battery. GENERAL LEAD BATTERIES COMPANY.

36. CHARGING A AND B BATTERIES—Various ways of connecting up batteries for charging purposes. WESTINGHOUSE UNION BATTERY COMPANY.

37. CHOOSING THE RIGHT RADIO BATTERY—Advice on what dry cell battery to use; their application to radio, with wiring diagrams. NATIONAL CARBON COMPANY.

53. TUBE REACTIVATOR—Information on the care of vacuum tubes, with notes on how and when they should be reactivated. THE STERLING MANUFACTURING COMPANY.

54. ARRESTERS—Mechanical details and principles of the vacuum type of arrester. NATIONAL ELECTRIC SPECIALTY COMPANY.

55. CAPACITY CONNECTOR—Description of a new device for connecting up the various parts of a receiving set, and at the same time providing bypass condensers between the leads. KURZ-KASCH COMPANY.

61. DRY CELLS—Information on the construction and operation of dry cells with a description of the methods used in testing them. THE CARBON PRODUCTS COMPANY.

68. CHEMICAL RECTIFIER—Details of assembly, with wiring diagrams, showing how to use a chemical rectifier for charging batteries. CLEVELAND ENGINEERING LABORATORIES COMPANY.

69. VACUUM TUBES—A booklet giving the characteristics of the various tube types with a short description of where they may be used in the circuit. RADIO CORPORATION OF AMERICA.

77. TUBES—A booklet for the beginner who is interested in vacuum tubes. A non-technical consideration of the various elements in the tube as well as their position in the receiver. CLEARTRON VACUUM TUBE COMPANY.

86. SHORT-WAVE RECEIVER—A booklet containing data on a short-wave receiver as constructed for experimental purposes. THE ALLEN D. CARDWELL MANUFACTURING CORPORATION.

87. TUBE TESTER—A complete description of how to build and how to operate a tube tester. BURTON-ROGERS COMPANY.

MISCELLANEOUS

38. LOG SHEET—A list of broadcasting stations with columns for marking down dial settings. U. S. L. RADIO, INCORPORATED.

41. BABY RADIO TRANSMITTER OF 9XH-9EK—Description and circuit diagrams of dry-cell operated transmitter. BURGESS BATTERY COMPANY.

42. ARCTIC RADIO EQUIPMENT—Description and circuit details of short-wave receiver and transmitter used in Arctic exploration. BURGESS BATTERY COMPANY.

43. SHORT-WAVE RECEIVER OF 9XH-9EK—Complete directions for assembly and operation of the receiver. BURGESS BATTERY COMPANY.

44. ALUMINUM FOR RADIO—A booklet containing much radio information with hook-ups of basic circuits, with inductance-capacity tables and other pertinent data. ALUMINUM COMPANY OF AMERICA.

45. SHIELDING—A discussion of the application of shielding in radio circuits with special data on aluminum shields. ALUMINUM COMPANY OF AMERICA.

58. HOW TO SELECT A RECEIVER—A commonsense booklet describing what a radio set is, and what you should expect from it, in language that any one can understand. DAY-FAN ELECTRIC COMPANY.

67. WEATHER FOR RADIO—A very interesting booklet on the relationship between weather and radio reception, with maps and data on forecasting the probable results. TAYLOR INSTRUMENT COMPANIES.

73. RADIO SIMPLIFIED—A non-technical booklet giving pertinent data on various radio subjects. Of especial interest to the beginner and set owner. CROSLLEY RADIO CORPORATION.

74. THE EXPERIMENTER—A monthly publication which gives technical facts, valuable tables, and pertinent information on various radio subjects. Interesting to the experimenter and to the technical radio man. GENERAL RADIO COMPANY.

75. FOR THE LISTENER—General suggestions for the selecting, and the care of radio receivers. VALLEY ELECTRIC COMPANY.

76. RADIO INSTRUMENTS—A description of various meters used in radio and electrical circuits together with a short discussion of their uses. JEWELL ELECTRICAL INSTRUMENT COMPANY.

78. ELECTRICAL TROUBLES—A pamphlet describing the use of electrical testing instruments in automotive work combined with a description of the cadmium test for storage batteries. Of interest to the owner of storage batteries. BURTON ROGERS COMPANY.

79. INSULATION—A comprehensive book giving valuable information on all types of insulating material used in electrical work. More for the technical man than for the average set owner. MITCHELL-RAND MANUFACTURING COMPANY.

USE THIS COUPON

RADIO BROADCAST SERVICE DEPARTMENT
RADIO BROADCAST, Garden City, New York.
Please send me (at no expense) the following booklets indicated by numbers in the published list

Name

Address

(City) (Stat.)

ORDER BY NUMBER ONLY

This coupon must accompany every request. RB 527

Use Power tubes
for good quality
at full volume

Simply adapt
to your set with
Connectoralds



For UX 171 and UX 112 Tubes, Na-Ald 112 Connectoralds are recommended for maximum volume with storage battery sets. These tubes will deliver without distortion several times the volume of the regular 201A. Price \$1.50.

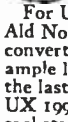

For UX 120 Tubes in UV 201A sockets, the Na-Ald No. 120 Connectorald should be used. To convert a storage battery set to dry batteries with ample loud speaker volume, use a UX 120 tube in the last audio stage with the 120 Connectorald and UX 199 tubes with 419X Adapters in the other sockets. Price \$1.25.



For the UX 120 Tube in UV 199 sockets, ample loud speaker volume without distortion is obtainable from any set equipped for UV 199 tubes by means of the UX 120 or equivalent tube with the Na-Ald No. 1920 Connectorald. The tube is raised slightly, but provides for its use in most sets with limited headroom. Price \$1.25.

For UX 120 tubes in the UV 199 sockets of the Radiola Superheterodyne Semi-Portable, and Radiola Super VIII. These excellent Superheterodynes will deliver ample volume for loud speaker operation when equipped with the UX 120 used with the Na-Ald No. 420 Connectorald. Price \$1.25.

ALDEN MANUFACTURING CO.

Dept. 13-25

Springfield, Mass.

To get the utmost
from those new High-Mu tubes

DESIGNED to official specifications for use with the new Radiotron and Cunningham Resistance-coupled High-Mu tubes, the new Lynch Metallized Resistance Coupled Amplifier Kit will give you perfect tone with full volume. May be used with any receiver. At all good dealers' or by mail, prepaid \$9.00. Write for literature.

ARTHUR H. LYNCH, Inc.

Member RMA

250 West 57th St.

New York, N. Y.

This is a good time to subscribe for

RADIO BROADCAST

Through your dealer or direct, by the year only \$4.00

DOUBLEDAY, PAGE & CO. GARDEN CITY, NEW YORK

Blurring?

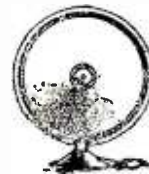

Type A
\$28.50

Not a trace
on the
**PACENT
CONE**

Every note—every
word is true and
faithful in repro-
duction.

PACENT RADIO CORP.
156 West 16th Street New York

LOOP SET OWNERS

ON RECEIPT of your order we will ship you by return mail one of our famous JENKINS INDUCTANCE - COUPLERS, which we unconditionally guarantee to INCREASE VOLUME 400%—MORE THAN DOUBLE DISTANCE and TRIPLE the NUMBER OF STATIONS you are now receiving.

ANY OWNER CAN INSTALL IN FIVE MINUTES. TRANSOCEANIC RECEPTION AND OTHER STARTLING DISTANCE RECORDS FREQUENTLY REPORTED BY PURCHASERS.

Your money cheerfully refunded IMMEDIATELY without question to any purchaser NOT ENTIRELY SATISFIED.

ORDER ONE TODAY

\$5.00

CASH -- CHECK -- MONEY ORDER

JENKINS RADIO CO.

BOX 41

BETTENDORF

IOWA



ELKAY
TRADE MARK

SENIOR SIX
With Truphonic Audio

Renders all tones from bass to treble in musical values. Brings in the voice in natural, human quality. Ample volume. Quiet tone background. Centralized control with micrometer adjustment for needlepoint selectivity.

Technically: (1) Truphonic Audio, (2) Synauto, synchronized, R F., (3) Uni-control, (4) Interchangeable tube system, (5) Complete shielding.

In fine, duco-finished mahogany cabinet, \$125; chassis only, \$102.50.

Jobbers—Write for franchise.

The Langbein-Kaufman Radio Co.
Dept. P, 62 Franklin St., New Haven, Conn.

Use
Elkay Tube Equalizers

Have You Had Difficulty
in obtaining parts for such receivers as the Aristocrat, Browning-Drake, Universal, R-B Lab, Daven Bass Note, Hammarlund Hi-Q, Loftin White, etc.?

Martin's Radio Service can supply you with these parts at once. Each order receives personal attention.

Write for Prices

MARTIN'S RADIO SERVICE
9052 206th St. Bellaire, Queens, N. Y. C.

Why not subscribe to *Radio Broadcast*? By the year only \$4.00; or two years, \$6.00, saving \$2.40. Send direct to Doubleday, Page & Company, Garden City, New York.



U. S. Patent, Oct. 12, 1926

Add the new Balkite Combination to your radio set now—with your "A" battery it supplies all radio power automatically from the light socket.

Ask your radio dealer
FANSTEEL PRODUCTS CO., INC.
North Chicago, Ill.



Bradleyunit
PERFECT FIXED RESISTOR

This package contains 5 Bradleyunits

No. 500 R
500,000 Ohms or .5 Megohms

Bradleyunits are superior to other types of resistors because they do not vary in resistance with age, and they are not affected by atmospheric changes or moisture.

Bradleyunit-A
PERFECT FIXED RESISTOR

CIRCUITS for B-eliminators, radio receivers, and other radio units usually require the use of one or more reliable fixed resistance units. In fact, fixed resistors are being used more extensively than ever, and the demand for high-grade units is growing, daily.

Bradleyunit-A is a solid molded fixed resistor, calibrated with great accuracy and fitted with silver-plated terminal caps which can be soldered without affecting the calibration of the unit. Bradleyunits are made in 20 different ratings for every purpose.



Ask your dealer for Bradleyunits, not "resistance units." They are sold in the distinctive Allen-Bradley checkered carton.

Mail this coupon to

ALLEN-BRADLEY CO.
278 Greenfield Ave., Milwaukee, Wis.

Please send me data on Bradleyunits and your folder on B-eliminator hook-ups.

Name.....

Address.....



demand
AEROVOX

FILTER CONDENSER BLOCKS

For Working Voltages of 200, 300, 400, 600 and 1000 Volts D. C.

Flexible leads for connections eliminate all possibilities of leakage from soldering.

AEROVOX WIRELESS CORPORATION
60-72 Washington Street
Brooklyn, N. Y.

Ideal for the new HI-MU tubes



THORDARSON
Autoformer

Trade-Mark Registered

All Frequency Amplifier

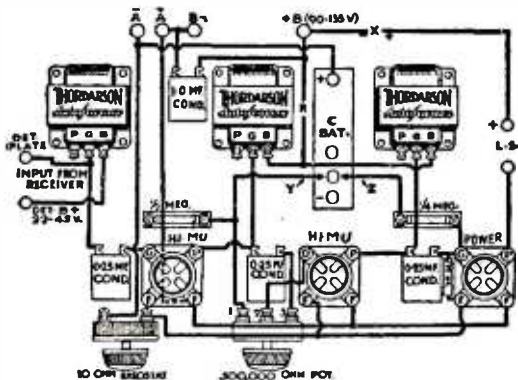

The Thordarson Autoformer used as a straight impedance makes an ideal coupling medium for the new Hi-Mu tubes UX-240 and CX-340.

The excellent tonal reproduction of the Autoformer combined with the high amplification of the Hi-Mu tubes plus a power tube on the output will transform your receiver into a real musical instrument.

The Autoformer is available at all good dealers at a price of \$5.00.

Mail this coupon today for more detailed information.

THORDARSON ELECTRIC MFG. CO.,
500 W. Huron St., Chicago, Ill.

Gentlemen:
Please send me more detailed information on the use of the Autoformer with Hi-Mu tubes.

Name.....

Address.....

3553-P



Volume
With
Clarity

DOUBLE ENJOYMENT
From Any Set With

Burns LOUD SPEAKER

Why sacrifice the excellent reproducing qualities of a set by the use of an inferior speaker. With a BURNS it is possible to reproduce with amazing exactness every note of music and inflection of voice that the set can pick up. A trial will convince.

AT YOUR DEALER'S OR WRITE DIRECT
Our line will be displayed at the R. M. A. Trade Show, Stevens Hotel, Chicago, Ill., June 13-18, 1927.

American Electric Company, Inc.
State and 64th Sts. Chicago, U. S. A.
Ask About BURNS B-Eliminator

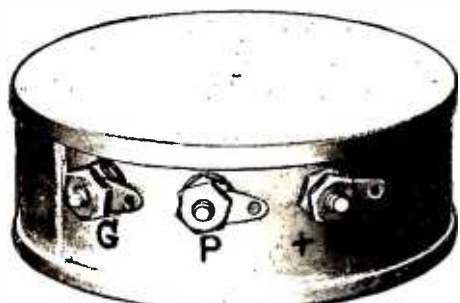

Shielded Tuned Radio Transformer, No. 30

SICKLES Diamond-Weave Coils

The new Sickles Shielded Tuned Radio Transformer prevents both outside and local interference. It is remarkably compact, sharp tuning, sturdy.

Sickles Diamond-weave coils have established an enviable reputation for low distributed capacity, low dielectric losses, and large range of frequency with small variable capacity.

The ideal coil for the Naald Localized Control Tuning Unit and for the Tru-Phonic Catacomb Assembly.

There are Sickles Diamond Weave Coils for all Leading Circuits.

The F. W. Sickles Co.
132 Union Street
SPRINGFIELD, MASS.

COIL PRICES

No. 30 Shielded Transformer.....	\$2.00 each
No. 24 Browning-Drake.....	7.50 Set
No. 18A Roberts Circuit.....	8.00 "
No. 25 Aristocrat Circuit.....	8.00 "

Intermediate Frequency Amplifica- tion at its Maximum

Only after years of experimenting have we perfected the "IrcO" Type BK Transformer. We claim that it is one of the outstanding radio inventions because:—

Totally shielded air core transformer.

No reoccurrence of any stations at two points on the dial.

High standard of accuracy, economical and fool-proof.

Ends of the windings are brought out through special lugs so that the user now solders direct and corrosion is impossible.

Special insulator impregnates the windings eliminating change of peak frequency.

Small size, so that it can be set behind a panel 10" x 17" x 8 1/2".

Quality of Tone, Selectivity and Faithfulness of Reproduction are unsurpassed.

If you cannot get this from your dealer order direct from us.

Descriptive literature on request.

Independent Radio Corporation

1516 Summer St. Philadelphia

Electrostatic condensers for all purposes

Faradon
WIRELESS SPECIALTY APPARATUS COMPANY
Jamaica Plain Boston, Mass.

RADIO FANS, a one-year's subscription to Radio Broadcast will cost you four dollars, two years six dollars. Consider this expenditure as being a necessary investment on your part for the future development of your own knowledge of Radio.



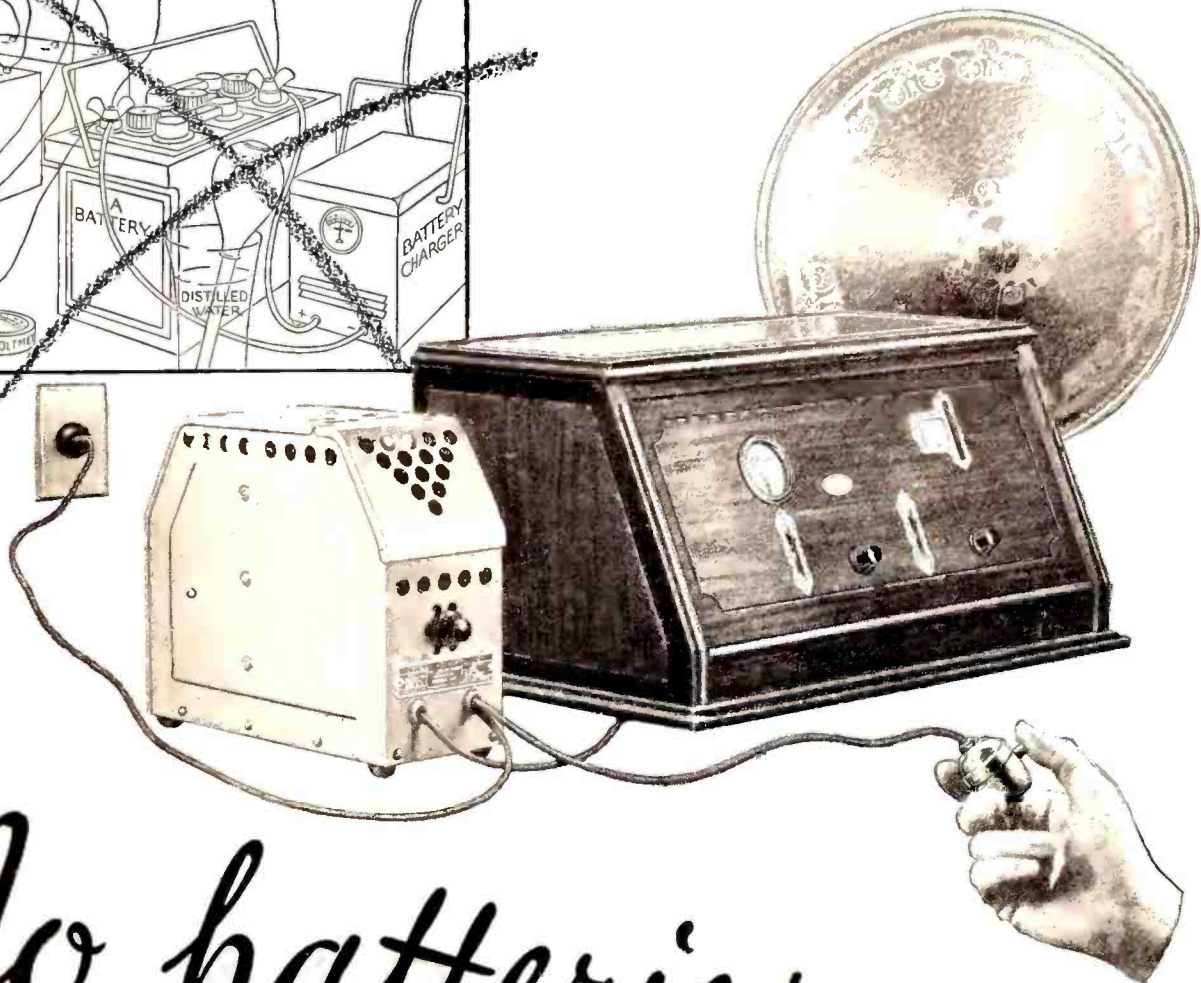
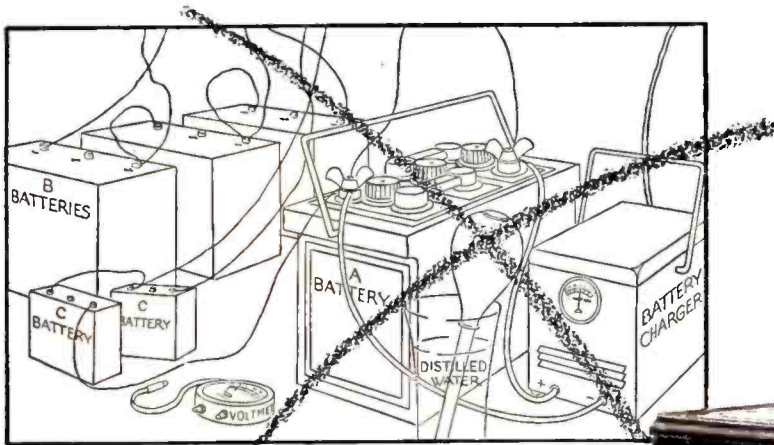

No batteries—

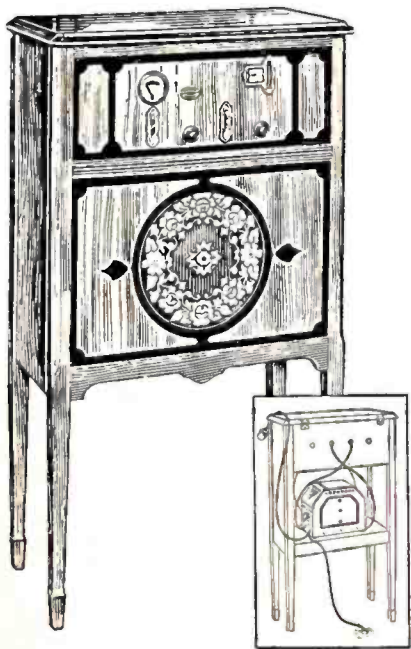

Radio's most revolutionary development! Run this radio direct from house current outlet. Ordinary 110 volt 60 cycle domestic electricity transformed mechanically into smooth, quiet radio A, B and C power as you use it. Radio power supply annoyances ended for all time. A snap of the switch is the only demand radio will make upon you from NOW ON.

- No more batteries to fuss with.
- No more trickle chargers to watch.
- No more keeping something filled with water.
- No batteries to renew or recharge.
- No upsetting the home to have the radio serviced.

See these wonderful sets at any Crosley dealers, or write Dept. 20 for descriptive literature.

The Crosley Radio Corporation

Powel Crosley, Jr.
President

CINCINNATI
OHIO

Radio Energy Unit

Crosley Radio Energy Unit weighs only 13 lbs., is only half the size of an ordinary A storage battery—operates without interfering hum and with the certainty of an electric motor.

\$50

6-tube AC Receivers

for use with Crosley Radio Energy Unit

Crosley radios designed for use with this marvelous power supply are the AC-7, a 6-tube table model at \$70, and the AC7-C, a 6-tube console at \$95.

Crosley sets are licensed under Armstrong U. S. Patent No. 1,113,149, or under patent applications of Radio Frequency Laboratories, Inc., and other patents issued and pending

Prices slightly higher west of the Rocky Mts

CROSLEY

RADIO

CROSLEY
ULTRA
MUSICONE
\$9.75

Radio is better with *battery* power

Eveready Layerbilt
"B" Battery No.
486, the Heavy-
Duty battery that
should be specified
for all loud-speaker
sets. Price \$5.00.



The Layerbilt pat-
ented construction
revealed. Each layer
is an electrical cell,
making automatic
contact with its
neighbors, and fill-
ing all available
space inside the bat-
tery case.

Here is *battery* power at its best

LIKE every other good battery, the Eveready Layerbilt provides only pure DC (Direct Current), steady, noiseless, the only current that can give you the best results of which your set is capable. Radio is better with *Battery* Power, always, for batteries alone produce pure DC, and are entirely reliable, convenient, available anywhere, always ready to work. For best results and satisfaction, use batteries, and for greatest economy, get the Eveready Layerbilt "B" Battery No. 486.

For years you have known Eveready Radio Batteries as "the kind that last longer"—and now you are finding that the Eveready Layerbilt "B" Battery No. 486 is the one that

lasts longest of all. So long does it last in proportion to its price that hundreds of thousands of people have found it to be the most economical battery they ever used. It is not only that, but on the basis of exceedingly careful scientific tests it is by far the most economical, dependable and satisfactory source of "B" power on the market today. These tests, unerringly revealing what each type of "B" power will do, have proved the superiority of the Layerbilt, and have shown why more and more people are adopting it.

It is a wonderful battery—no wonder when you look at its construction! It is built in layers of *flat* current-producing elements. That's why it is called

the "Layerbilt." This unique patented Layerbilt method utilizes every available inch inside the battery case, avoids waste space, eliminates many soldered connections. It puts more active materials inside the battery, and makes them more efficient, more reliable, longer-lasting.

NATIONAL CARBON CO., INC.
New York San Francisco
Unit of Union Carbide and Carbon Corporation

Tuesday night is Eveready Hour Night—
9 P. M., Eastern Standard Time

WEAF—New York	WGN—Chicago
WJAR—Providence	WOC—Davenport
WEEL—Boston	WCCO { Minneapolis
WTAG—Worcester	{ St. Paul
WFI—Philadelphia	KSD—St. Louis
WGR—Buffalo	WRC—Washington
WCAE—Pittsburgh	WGY—Schenectady
WSAI—Cincinnati	WHAS—Louisville
WTAM—Cleveland	WSB—Atlanta
WWJ—Detroit	WSM—Nashville
	WMC—Memphis